

Department of Physics
Birla Institute of Technology, Mesra, Ranchi

List of Physics Lab Experiments for B.Tech students

0. Error analysis in Physics Laboratory
1. To determine the frequency of AC mains with the help of sonometer
2. To determine the resistance per unit length of a Carey Foster's bridge wire and resistivity of unknown wire.
3. Measurement of electrical equivalent of heat
4. To determine the wavelength of sodium lines by Newton's rings method
5. To determine the frequency of tuning fork using Melde's Experiment
6. Measurement of voltage and frequency of a given signal using CRO
7. To determine the emf of a cell using stretched wire potentiometer
8. Determination of refractive index of the material of a prism using spectrometer and sodium light
9. To study the frequency response of a series LCR circuit
10. To study Lorentz force using Current balance
11. Study of electromagnetic induction and verification of Faraday's laws.
12. To determine Wavelength of prominent spectral lines of mercury light by a plane transmission grating.

EXPERIMENT NO. 00

Aim of the experiment : Error analysis in physics laboratory

Introduction to Uncertainty: In introductory lab work, such as in Physics labs, you usually know in advance what the result is supposed to be. You can compare your actual result with the anticipated result, and calculate an actual error value. In real-world laboratory work, on the other hand, you usually *don't* know in advance what the result is supposed to be. If you *did*, you probably wouldn't be doing the experiment in the first place! When you state your final result, it's important to state also, how much you think you can trust that result, in the form of a numerical uncertainty (or error in measurement). For example, you might state the volume of an object as

$$V = 43.25 \pm 0.13 \text{cm}^3 \quad (1.1)$$

When we state the uncertainty in this form, without further elaboration, it generally means that we think that the true value has about a 68% chance of being within that range. A more precise statement would include the confidence level of the uncertainty range, which might be 68% or 95% or even 99%. Usually, in an experiment we measure some number of quantities directly, and combine them mathematically to get a final result. Therefore, estimating the final uncertainty usually involves two steps. First, we must estimate the uncertainties in the individual quantities that we measure directly. Second, we must combine those uncertainties to get the overall uncertainty, in a way that corresponds to the way that we combine individual measurements to get the final result.

Estimating the Uncertainty in a Single Measurement

Normal analog scale

(e.g. meter stick) Estimate the final digit by interpolating between the smallest scale divisions, and make the uncertainty ± 1 or ± 2 in that last digit (use your judgment in deciding).

Analog scale with vernier

(e.g. vernier caliper or micrometer) Use the vernier scale to get the last digit, and make the uncertainty ± 0.5 of that last digit.

Physics Laboratory Manual

1.2.1 Digital scale

(e.g. digital multimeter) If the reading is steady, make the uncertainty ± 0.5 of the last digit; otherwise take several instantaneous readings, average them, and find the standard deviation of the mean as described below.

1.3 Estimating the Uncertainty in an Averaged Measurement

If you can make several measurements x_1, x_2, \dots, x_N , calculate the mean, \bar{x} , and use that as "the" measurement. Then calculate the standard deviation of

the mean and use this as the uncertainty, $\Delta\bar{x}$. If your calculator has a standard deviation function, divide its result by \sqrt{N} to get the standard deviation of the mean.

$$\Delta\bar{x} = \frac{\sqrt{(x_1 - \bar{x})^2 + (x_2 - \bar{x})^2 + (x_3 - \bar{x})^2 + \dots + (x_N - \bar{x})^2}}{\sqrt{N}} \quad (1.2)$$

In the following equations, Δx means the absolute uncertainty in which is the number you get from one of the methods above; it has units just like the measurement itself has. $\Delta x\%$ means the percent (or fractional) uncertainty in x , which is the uncertainty expressed as a percentage or fraction of the measurement; it has no units.

1.4.1 Addition and Subtraction

If $z = x + y$ or $z = x - y$,

$$\Delta z = \sqrt{(\Delta x)^2 + (\Delta y)^2} \quad (1.3)$$

If you're adding and subtracting more variables, simply add more terms inside the square root.

1.4.2 Multiplication and Division

If $z = xy$ or $z = x/y$

$$\frac{\Delta z}{z} = \sqrt{\left(\frac{\Delta x}{x}\right)^2 + \left(\frac{\Delta y}{y}\right)^2} \quad (1.4)$$

or (same thing in different notation).

$$\Delta z\% = \sqrt{(\Delta x\%)^2 + (\Delta y\%)^2} \quad (1.5)$$

Physics Laboratory Manual

If you're multiplying and dividing more variables, simply add more terms inside the square root.

1.4.3 Powers, Including Roots

If $z = x^n$

$$\frac{\Delta z}{z} = n \left(\frac{\Delta x}{x} \right) \quad (1.6)$$

1.4.4 More Complicated Calculations

Sometimes you can combine the three rules given above, doing the calculation one step at a time, combining uncertainties as you go along, and switching back and forth between absolute and percent uncertainties as necessary. However, you cannot do this if the same variable appears more than once in the equation or calculation, or if you have situations not covered by the rules given above, such as trig functions. In such cases you must use the general procedure given below.

The following table gives an idea about the relation between error and actual equation:

Table 1.1: Some examples

S. No.	Relation between Z and (A, B)	Relation between error Δz and (ΔA , ΔB)
1	$Z = A + B$	$(\Delta Z)^2 = (\Delta A)^2 + (\Delta B)^2$
2	$Z = A - B$	$(\Delta Z)^2 = (\Delta A)^2 + (\Delta B)^2$
2	$Z = AB$	$\left(\frac{\Delta Z}{Z}\right)^2 = \left(\frac{\Delta A}{A}\right)^2 + \left(\frac{\Delta B}{B}\right)^2$
3	$Z = A/B$	$\left(\frac{\Delta Z}{Z}\right)^2 = \left(\frac{\Delta A}{A}\right)^2 + \left(\frac{\Delta B}{B}\right)^2$
4	$Z = An$	$\frac{\Delta Z}{Z} = n \frac{\Delta A}{A}$
5	$Z = \ln A$	$\Delta Z = \frac{\Delta A}{A}$
6	$Z = e^A$	$\frac{\Delta Z}{Z} = \Delta A$

1.5 General Procedure

If $z = f(x, y)$, first calculate the differences caused by the uncertainty in each variable separately ;

Physics Laboratory Manual

$$(\Delta z)_x = f(x + \Delta x, y) - f(x, y) \quad (1.7)$$

$$(\Delta z)_y = f(x, (y + \Delta y)) - f(x, y)$$

Then combine the differences to get the total uncertainty:

$$\Delta z = \sqrt{(\Delta z)_x^2 + (\Delta z)_y^2} \quad (1.8)$$

If there are more variables, extend these equations appropriately by adding more terms. If a variable occurs more than once in the formula for $f(x,y)$, change all occurrences simultaneously when calculating the difference for that variable.

To illustrate the procedure for calculation the error in an experiment, we will work out the average (mean) value x and the standard deviation of the mean, and the standard deviation of an individual data point, using the position measurements in the accompanying Table 2.

	\bar{x}	(Δx)
15.68	0.15	0.0225
15.42	0.11	0.0121
15.03	0.50	0.2500
15.66	0.13	0.0169
15.17	0.36	0.1296
15.89	0.36	0.1296
15.35	0.18	0.0324
15.81	0.28	0.0784
15.62	0.09	0.0081
15.39	0.14	0.0196
15.21	0.32	0.1024
15.78	0.25	0.0625
15.46	0.07	0.0049
15.12	0.41	0.1681
15.93	0.40	0.1600
15.23	0.30	0.0900
15.62	0.09	0.0081

Physics Laboratory Manual

15.88	0.35	0.1225
15.95	0.42	0.1764
15.37	0.16	0.0256
15.51	0.02	0.0004

Table 1.2 : Position Measurements.

From the above table we can make the following calculations:

$$n = 4, \quad x = 326.08 \text{ m}, \quad (\Delta x) = 1.620 \text{ m}$$

And then evaluate the following quantities:

$$\bar{x} = \frac{\sum x_i}{n} = \frac{326.08}{4} = 15.53 \quad 1.9$$

$$\sigma = \frac{\sum (\Delta x_i)^2}{n} = \frac{0.35^2 + 0.42^2 + 0.16^2 + 0.02^2}{4} = 0.062 \quad 1.10$$

$$\sigma = \sqrt{\frac{\sum (\Delta x_i)^2}{n}} = \sqrt{\frac{0.35^2 + 0.42^2 + 0.16^2 + 0.02^2}{4}} = 0.063 \quad 1.11$$

The error or spread in individual measurements is $\sigma = 0.28$ m. But for the mean $\bar{x} \pm \sigma = 15.53 \pm 0.06$ m. This says the average is 15.53 m which has an error of 0.06 m. Or putting it another way, there is about a 68% probability that the true value of x falls, in the range 15.47 m to 15.59 m. In some cases, the fractional error σ / \bar{x} , or relative error, is of more interest than the absolute value of σ . It is possible that the size of σ is large while the fractional error is small. Note that increasing the number of individual measurements on the uncertainty of the average reduces the statistical uncertainty (random errors); this improves the "precision". On the other hand, more measurements do not diminish systematic error in the mean because these are always in the same direction; the "accuracy" of the experiment is limited by systematic errors.

Slide Calipers

Table: Determination of thickness of the experimental table

Physics Laboratory Manual

Sl No.	MSR	VSR	Total=MSR+VSR*LC x_i	AVG	$x_i - \bar{x}$

$$\bar{x} = \frac{\sum (x_i - \bar{x})}{(n - 1)}$$

Therefore, thickness of the experimental table is $(\bar{x} + \dots) = \dots$

Screw Gauge

Table: Determination of diameter of a given wire

Sl No.	MSR	CSR	Total = MSR+VSR*LC x_i	AVG	$x_i - \bar{x}$

$$\bar{x} = \frac{\sum (x_i - \bar{x})}{(n - 1)}$$

Therefore, diameter of the given wire is $(\bar{x} + \dots) = \dots$

Spherometer:

Physics Laboratory Manual

Table: Determination of thickness of a given glass plate

SI No.	MSR	CSR	Total = MSR+VSR*LC x_i	AVG	$x_i - \bar{x}$

$$\frac{\sum (x_i - \bar{x})}{(n - 1)}$$

Therefore, thickness of a given glass plate is $(\bar{x} + \Delta x) = \dots\dots$

1.6 Suggested Experiments:

1. Measure the diameter of a wire using a screw gauge at 10 different places on the wire. Calculate the standard deviation in your measurements.
2. Measure the thickness of a table top at using a scale in cm. Calculate the error in your measurements.
3. Measure the period of oscillations of a pendulum using your wrist watch and record your data ten times. Estimate the standard deviation and error in your measurements.
4. Ask your partner to drop a solid object at a same height for 10 times. Measure the time of flight with your wrist watch. The same can be repeated by your other partners also. Compare the standard deviation of each of your measurements.

EXPERIMENTS NO. 01

Aim: To determine the frequency of AC Mains with the help of Sonometer.

Apparatus: Sonometer with non-magnetic wire (Nichrome), Ammeter, step down transformer (2-10 Volts), Key, Horseshoe magnet, Wooden stand for mounting the magnet, Set of 50 gm masses, Screw gauge and meter scale (fitted with the sonometer).

Description of the apparatus: As shown in the given figure below, an uniform Nichrome (non-magnetic) wire is stretched on a hollow wooden box (sonometer), one side of which is tied to the hook H, while the other passes over a frictionless pulley P, a hanger carrying masses is also attached to this end of the non-magnetic wire, a permanent strong horse shoe magnet NS is kept at the middle of the Nichrome wire in such a way that it produces a magnetic field perpendicular to the direction of current, to be flown in the Nichrome wire. Two moveable sharp edged bridges A and B are provided on the wooden box for stretching wire. A step down transformer (2-10V) is connected across the wire.

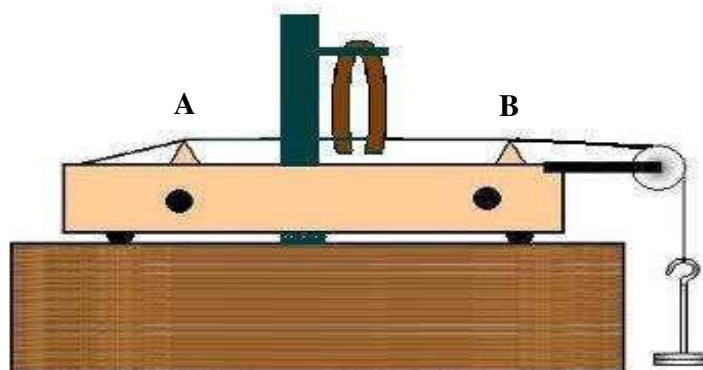

Fig-1: Schematic diagram for sonometer with suggested accessories.

Physics Laboratory Manual

Working Principle: Let a sonometer wire stretched under a constant load be placed in an uniform magnetic field applied at the right angles to the sonometer wire in the horizontal plane and let an alternating current of low voltage (by means of the step down transformer) be passed through the wire. On account of interaction, between the magnetic field and the current in the wire ($F = il \times B$), the wire will be deflected. The direction of deflection is being given by the Fleming's left hand rule. As the current is alternating, for half the cycle the wire will move upwards and for the next half the wire will move downwards. Therefore the sonometer wire will receive impulses alternately in opposite directions at the frequency of the alternating current passing through the wire. As a consequence the wire will execute forced vibrations with a frequency of the AC mains (under the conditions of resonance) in the sonometer wire.

The frequency of AC Mains, which is equal to the frequency of vibration of the sonometer wire in its fundamental mode (only one loop between the two bridges A and B, i.e., having two nodes and one antinode between the two bridges) is given by (under resonance conditions):

$$f = \frac{1}{2l} \sqrt{\frac{T}{m}} \quad (1)$$

where T is the tension applied on the wire and given by $T = Mg$, M being the total mass loaded on the wire (i.e., total mass kept on the hanger and the mass of the hanger) and g the acceleration due to gravity. Symbol l presents the length of the sonometer wire between the two bridges. The mass per unit length of the sonometer wire is represented by symbol m and can be calculated in terms of the radius r of the sonometer wire, and the density d of the material wire (Nichrome) as

$$m = \pi r^2 d \quad (2)$$

Substitution of value of m, evaluated from the equation 2, in equation 1, gives the value of frequency of AC mains.

Physics Laboratory Manual

Procedure:

1. Measure the diameter of the wire with screw gauze at several points along its length. At each point two mutually perpendicular diameters 90° should be measured. Evaluate the radius of the sonometer wire.[See observation table (a)]
2. Connect the step down transformer to AC mains and connect the transformer output (6 Volts connection) to the two ends of the sonometer wire through a rheostat, ammeter and a key, as shown in the figure.
3. Place the two movable sharp-edged bridges A and B at the two extremities of the wooden box.
4. Mount the horse shoe magnet vertically at the middle of the sonometer wire such that the wire passes freely in between the poles of the magnet and the face of the magnet is normal to the length of the wire. The direction of current flowing through the wire will now be normal to the magnetic field.
5. Apply a suitable tension to the wire, say by putting 100 gm masses on the hanger [tension in the wire = (mass of the hanger + mass kept on the hanger) g]. Switch on the mains supply and close the key K and then adjust the two bridges A and B till the wire vibrates with the maximum
6. Amplitude (in the fundamental mode of resonance) between the two bridges. Measure the distance between the two bridges (l).[See observation table (b)]
7. Increasing the load M by steps of 50 gm, note down the corresponding values of l for maximum amplitude (in the fundamental mode of resonance). Take six or seven such observations.
8. Knowing all the parameters, using the relations given in equations 1 and 2 calculate the frequency of AC mains for each set of observation separately and then take mean.
9. Also plot a graph between the mass loaded, M along the X-axis and the square of the length (l^2) along Y-axis. This graph should be a straight line. Find the slope of this line and then using the equations 1 and 2, calculate the frequency of AC mains from this graph also.

Physics Laboratory Manual

(Frequency (n) = $\frac{\text{---}}{(4 \times \text{slope} \times \text{---})}$).

Physics Laboratory Manual

Observations:

1. Measurement of radius of sonometer wire (r)

a. Least count of screw gauge = cm

b. Zero error of the screw gauge = cm

2. Measurement of T , l and frequency of the AC Mains

a. Mass of the hanger = 50 gm

b. Acceleration due to gravity (g) = 980 cm/sec².

c. Density of sonometer wire (nichrome) = 8.18848 gm/cc

Table (a): Measurement of radius of sonometer wire (r)

S.No	Diameter of wire along one direction (cm)	Diameter of wire in (cm)	Mean observed diameter (cm)	mean corrected diameter (cm)	mean radius r (cm)
1.					
2.					
3.					
4.					
5.					

Physics Laboratory Manual

Table (b): Measurement of T, l and frequency of the AC Mains

S. No	Total Mass Loaded = Mass of hanger + Mass on it M (gm)	Tension in wire T = Mg (gm cm/s ²)	Position of first bridge a (cm)	Position of second bridge b (cm)	Length of wire between two bridges $l=a-b$ (cm)	Frequency (Hz)
1						
2						
3						
4						
5						
6						
7						

1. Mean value of the AC Mains frequency =Hz.

2. Calculations from the graph are also to be given on the left side of paper.

3. The slope of graph plotted between Mass loaded (M) and the square of length $S = \text{units}$

4. AC mains frequency when calculated from the graph = $(n) = \frac{\text{...}}{(4 \times \text{slope} \times \text{...})}$ Hz

Results: The frequency of AC Mains as calculated

a. Experimental calculations: Hz.

b. Graphical calculations:Hz (Graph is attached)

c. Standard Value: 50 Hz (in this country)

d. Percentage Error:..... %

Sources of errors and precautions

1. The sonometer wire should be uniform and without kinks.
2. The pulley should be frictionless
3. The wire should be horizontal and pass freely in between the poles of magnet.
4. The horse shoe magnet should be placed vertically at the center of the wire with its face normal to the length of wire.
5. The current should not exceed one Ampere to avoid the overheating of the wire.
6. The movement of bridges on the wire should be slow so that the resonance point can be found easily
7. The diameter of the wire must be measured accurately at different points in two mutually perpendicular directions.
8. The sonometer wire and the clamp used to hold the magnet should be non-magnetic.

SAMPLE ORAL QUESTIONS

1. What do you understand by the frequency of AC Mains?
2. Distinguish between AC and DC. What is the use of magnet here?
3. How does the sonometer wire vibrate when AC is passed through it?
4. If you pass a DC through the wire, will it vibrate?
5. What are the chief sources of errors in this experiment?
6. What is the use of magnet here?
7. What is Fleming's left hand rule?
8. What is resonance?
9. What is fundamental mode of vibration?
10. Why do we take the material of wire to be non-magnetic?
11. What is the principle of this experiment?

EXPERIMENTS NO. 02

Aim of the Experiment: To determine the resistance per unit length of a Carey Foster's bridge wire and then to find the resistivity of the material of a given wire.

Apparatus Required: Carey Foster's bridge, Leclanche cell, Weston galvanometer, 1- Ohm coil, Sliding rheostat of small resistance, Plug key, Thick copper strips, Shunt wire and Connecting wires.

Theory of Carey Fosters Bridge: Carey Foster's bridge is especially suited for the comparison of two nearly equal resistances whose difference is less than the resistance of the bridge wire. As shown in fig.1, two resistances X and Y to be compared are connected in the outer gaps of the bridge in series of the bridge wire. These two resistances together with the bridge wire from the two arms of the Wheatstone bridge. One composed of X plus a length of the bridge wire up to the balance point and the second composed of Y plus the rest of the bridge wire. The remaining two arms are formed by two nearly equal resistances P and Q, which are connected in the inner gaps of the bridge. If l be the reading on the scale of the position of the null point, we have, from usual Wheatstone bridge principle.

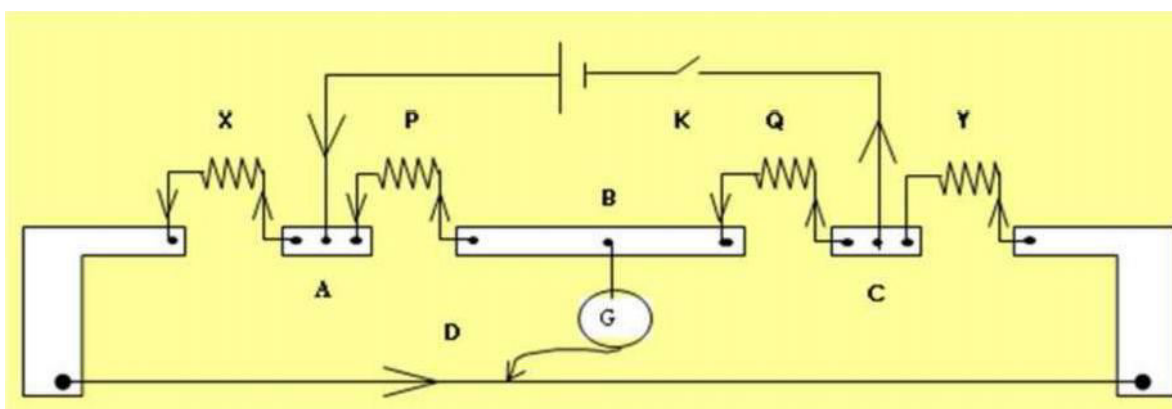

Figure 1: Circuit diagram for the experiment on Carey-Foster's bridge

Physics Laboratory Manual

$$R = \frac{R_1}{R_2} \quad (1)$$

or

$$R + 1 = \frac{R_1}{R_2} \quad (2)$$

where, R_1 and R_2 in units of length of the bridge wire are the end corrections at the left and right ends of the bridge wire respectively and R is the resistance per unit length of the bridge wire. If now X and Y are interchanged and R_2 be the reading on the scale of the position of the new null point, we have

$$R = \frac{R_2}{R_1} \quad (3)$$

$$R + 1 = \frac{R_2}{R_1} \quad (4)$$

Comparing equations (2) and (4) we see that the fraction on the right hand side are equal and since their numerators are identical their denominators must also be equal. Hence equating the denominators of the right hand sides of equation (2) and (4), we have

$$R_1 + (100 - R_1) = R_2 + (100 - R_2) \quad (5)$$

$$R_1 = R_2 \quad (6)$$

Thus the difference between the resistances X and Y can be obtained by determining the resistance of the bridge wire between the two null points.

Working Principle: Let two resistances P and Q of nearly equal values be connected in the inner gaps of a Carey Foster's bridge and let a known resistance R be connected in the outer left gap of the

Physics Laboratory Manual

bridge. Let a thick copper strip be connected in the outer right gap of the bridge and assume that l_1 and l_2 are respectively the reading on the scale of the positions of the null point on the bridge wire before and after interchanging the known resistance R and the thick copper strip in the outer gaps, then we have from eq. (6) by putting $X = R, Y = 0$

$$= \left(\frac{l_1}{l_2} - 1 \right), \quad \text{or} \quad = \frac{l_1 - l_2}{l_2} \quad (7)$$

Now let the coil of unknown resistance X be connected in the outer left gap and a standard known resistance Y of nearly the same value in the outer right gap of the bridge. Then if l_1 and l_2 be the readings on the scale of the positions of the null point before and after interchanging X and Y , we have, from equation (6).

$$\frac{l_1}{l_2} = \left(\frac{X}{Y} - 1 \right) \quad (8)$$

$$= \left(\frac{l_1}{l_2} - 1 \right) + 1 \quad (9)$$

This equation can be used to calculate X , if Y is determined from equation (7).

Let L be the length of the wire and 'a' is the cross-sectional area of the wire.

Then the resistivity ρ is related to X by

$$X = \frac{\rho L}{a} \quad (10)$$

or

$$= \frac{X a}{L} \quad \text{Ohm-cm.} \quad (11)$$

Method to determine : Connect a standard 1 ohm resistance in the left gap of a Carey Foster's bridge and a thick copper strip in its outer right gap as shown in Fig. 1. Next connect the two resistance boxes P & Q at the inner gap of the C-F bridge as shown in the fig. Jockey is connected through the galvanometer as shown. Finally connect the Lechlanche cell between A and C including a plug key

Physics Laboratory Manual

K in the circuit. Put $P = Q$ from the resistance boxes and adjust for the null point. Measure and interchanging the two resistances in the outer gaps of the bridge. Follow the observation table. Calculate the value of r for each set of observations separately from equation (7) and then find the mean value of r . To find the resistance of the given wire, replace the copper strip by the wire and repeat the process. Find the resistance of the given wire using equation (6) after measuring its radius and length of the wire. Calculate the resistivity using equation (7).

Observations:

Length of the wire $L = \dots\dots\dots\text{cm}$ Ω

Resistance per unit length: $= \underline{\hspace{2cm}}$
()

Table 1: Determination of

S.No.	R (ohm)	P=Q (ohm)	Position of balance point with copper strip in the		($\frac{-}{\text{cm}}$)	(ohm/cm)	Mean in (ohm/cm)
			Right gap 11 (cm)	Left gap 12 (cm)			

Table 2: Determination of resistance and resistivity of the unknown wire

Unknown wire is nichrome (Ni,Fe,Cr alloy) here.

S.No	R (ohm)	P=Q (ohm)	Position of balance point with copper strip in the		($\frac{-}{\text{cm}}$)	$\frac{\Delta}{\text{ohm}}$ ($\frac{-}{\text{ohm}}$)	X (ohm) mean
			Right gap 11 (cm)	Left gap 12 (cm)			

Physics Laboratory Manual

--	--	--	--	--	--	--	--

Results and discussion:

$$= \dots \dots \dots \text{ohm/cm}$$

Standard value of resistivity of nichrome at room temperature $\sim 100 \times 10^8 \Omega\text{m}$.

Percentage of error:

Sources of error and precautions:

1. The ends of the connecting wires should be clean and all connections should be firmly made. The decimal - ohm box and thick copper strips should connect the given one-ohm resistance.
2. A rheostat should be used to introduce the resistances P and Q in the inner gaps of the bridges and the sliding contact should be adjusted to be approximately in the middle. It is not absolutely necessary that P and Q should be exactly equal except for high sensitiveness of the bridge, nor should their values be known. If $P = Q$, the positions of null point before and after interchanging the resistances in the outer gaps will be at equal distances from the middle 'point of the bridge wire, provided, of course, the wire is uniform. If P and Q differ very much it will not be possible to obtain the two positions of the null point on the bridge wire. The use of rheostat to introduce P and Q in the inner gaps possesses several advantages. Besides being cheap, it is flexible, for it can be used to obtain the null point in any part of the bridge wire and also enables us to take several sets of readings for (-) for the same values of X and Y. With fixed values for P and Q this could not have been possible.
3. In order that the bridge may have high sensitiveness, the resistances of the four arms should be of the same order.
4. In order to reduce the inaccuracy in the result due to a small error in reading the position of the null point to minimum, the null points while comparing X and Y should lie as near the middle of the bridge wire as possible.

Physics Laboratory Manual

5. While determining the value of R should be comparable with the resistance of the bridge wire so that the two positions of the null point before and after interchanging the resistances in the outer gaps lie near the ends of the bridge wire. The value of $(\frac{R}{r})$ will then be almost equal to the entire length of the bridge wire and the error in the value of $(\frac{R}{r})$ due to non-uniformity of the bridge wire will be reduced to minimum.
6. A plug key should be included in the cell circuit and should only be closed when observations are being made.
7. The galvanometer should be shunted by a low resistance wire to avoid excessive deflection in it when the bridge is out of balance. The exact position of the null point should be determined with full galvanometer sensitivity by removing the shunt wire from it.
8. The cell circuit should be closed before depressing the jockey over the bridge wire, but when breaking, reverse order should be followed.
9. The jockey should always be pressed gently and the contact between the jockey and the bridge wire should not be made while the jockey is being moved along.

EXPERIMENT NO. 03

Electrical Equivalent of Heat ‘J’

Aim: To determine the a) electrical equivalent of heat (J) and b) efficiency of an incandescent lamp

Apparatus: Electrical equivalent of heat jar, calorimeters, India Ink, regulated power supply of delivering up to 3A at 12 V, digital Volt-Ammeter, stop watch, thermometer and weighing balance

Theory: The theory for electrical energy and power was developed using the principles of mechanical energy, and the units of energy are the same for both electrical and mechanical energy. However, heat energy is typically measured in quantities that are separately defined from the laws of mechanics and electricity and magnetism. Sir James Joule first studied the equivalence of these two forms of energy and found that there was a constant of proportionality between them and this constant is therefore referred to as the Joule equivalent of heat and given the symbol J. The Joule equivalent of heat is the amount of mechanical or electrical energy contained in a unit of heat energy. The factor is to be determined in this experiment.

It is an experimental observation that when a current runs through a wire, the wire will increase its temperature. On a microscopic level, this is because the electrons constituting the current will collide with the atoms in the wire and in this collision process some energy is transferred from the electrons to the wire. The initial source of this energy is electrical and originates from a power supply. The final form of energy is heat as it radiates outward from and throughout the wire. The amount of electrical energy transformed into heat will depend on the current passing through the wire, the number and speed of the electrons and the resistance in the wire which is related to the above collision process.

We can relate the power P to thermal energy transfer (heat) Q during some time interval Δt using the relationship $P = Q/\Delta t$.

Combining the definition of electrical power in terms of current I and electric potential difference V with Ohm's law $V = IR$ when applied to a resistance R yields $P = Q/\Delta t = IV = I(IR) = I^2R$ (1) which we can rearrange to get

$$Q = P\Delta t = IV \Delta t. \quad (2)$$

The expression arises from the definition of the relationship between energy and power. This amount of heat is being provided to the wire in a time Δt while a given current I is flowing through the resistance R (in our experiment, it is filament of the bulb). In our experiment, this heat is then transferred to a container of water, causing the temperature of the water and jar to rise according to the formula

Physics Laboratory Manual

$$H = M_w \cdot c_w \cdot \Delta T + M_e \cdot c_e \cdot \Delta T \quad (3)$$

Where M_w is mass of water, c_w is specific heat of water, ΔT is temperature rise, M_e is mass of the jar and c_e is specific heat of the jar.

The electrical equivalent of heat (J) is

$$J = Q/H \quad (4)$$

Important instructions: When using the Electrical Equivalent of Heat (EEH) Apparatus, always observe the following precautions:

- ① Do not fill the water beyond the line indicated on the EEH Jar. Filling beyond this level can significantly reduce the life of the lamp.
- ② Illuminate the lamp only when it is immersed in water.
- ③ Never power the incandescent lamp at a voltage in excess of 13 V.

Procedure:

1. Measure and record the room temperature (T_r).
2. Weigh the EEH (electrical equivalent of heat) Jar (with the lid on), and record its mass (M_j).
3. Remove the lid of the EEH Jar and fill the jar to the indicated water line with cold water. **DO NOT OVERFILL.** The water should be approximately 10°C below room temperature, but the exact temperature is not critical.
4. Add about 10 drops of India ink to the water; enough so the lamp filament is just barely visible when the lamp is illuminated.
5. Using leads with banana plug connectors, attach your power supply to the terminals of the EEH Jar. Connect a voltmeter and ammeter as shown in Figure 1.1 so you can measure both the current (I) and voltage (V) going into the lamp. NOTE: For best results, connect the voltmeter leads directly to the binding posts of the jar.
6. Turn on the power supply and quickly adjust the power supply voltage to about 11.5 volts, then shut the power off. **DO NOT LET THE VOLTAGE EXCEED 13 VOLTS.**
7. Insert the EEH Jar into one of the styrofoam Calorimeters.
8. Insert your thermometer or thermistor probe through the hole in the top of the EEH Jar. Stir the water gently with the thermometer or probe while observing the temperature. When the temperature warms to about 6 or 8 degrees below room temperature, turn the power supply on.
9. Record the current, I, and voltage, V. Keep an eye on the ammeter and voltmeter throughout the experiment to be sure these values do not shift significantly. If they do shift, use an average value for V and I in your calculations.
10. When the temperature is as far above room temperature as it was below room temperature ($T_r - T_i = \text{Temperature} - T_r$), shut off the power and record the time (t_r). Continue stirring the water gently.

Physics Laboratory Manual

Watch the thermometer or probe until the temperature peaks and starts to drop. Record this peak temperature (T_f).

11. Weigh the EEH Jar with the water, and record the value (M_{jw}).

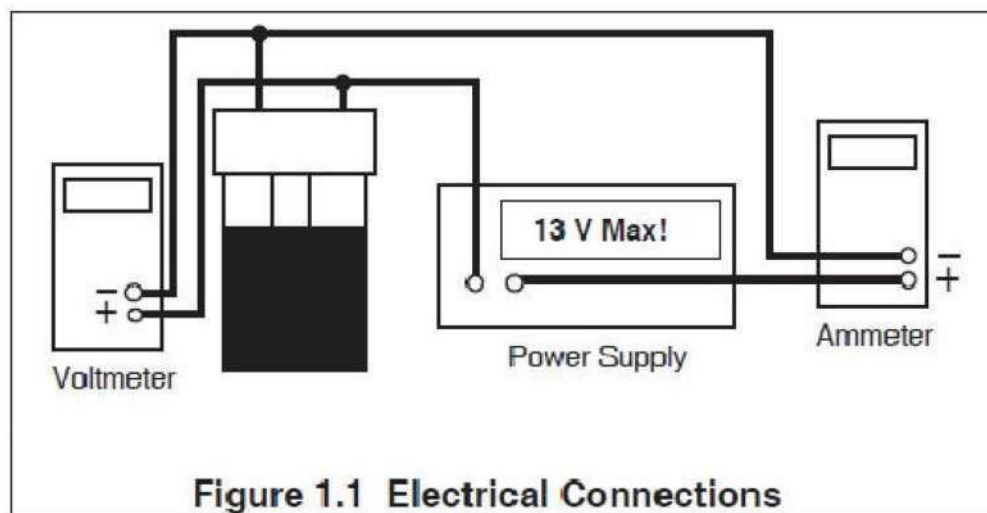

Data

$T_r =$ _____

$M_j =$ _____

$M_{jw} =$ _____

$V =$ _____ $I =$ _____

$t_i =$ _____ t_f

$=$ _____

$T_i =$ _____

$T_f =$ _____

Physics Laboratory Manual

Calculations:

In order to determine the electrical equivalent of heat (J_e), it is necessary to determine both the total electrical energy that flowed into the lamp (E) and the total heat absorbed by the water (H).

E, the electrical energy delivered to the lamp:

$E = \text{Electrical Energy into the Lamp} = V \cdot I \cdot t = \underline{\hspace{4cm}}$ $t = t_f - t_i = \text{the}$
time during which power was applied to the lamp = $\underline{\hspace{2cm}}$

H, the heat transferred to the water (and the EEH Jar):

$$H = (M_w + M_e)(1 \text{ cal/gm } ^\circ\text{C})(T_f - T_i) = \underline{\hspace{4cm}}$$

$$M_w = M_{jw} - M_j = \text{Mass of water heated} = \underline{\hspace{4cm}}$$

$M_e = 23$ grams. Some of the heat produced by the lamp is absorbed by the EEH Jar. For accurate results, therefore, the heat capacity of the jar must be taken into account (The heat capacity of the EEH Jar is equivalent to that of approximately 23 grams of water.)

J_e , the Electrical Equivalent of Heat:

$$J_e = E/H = \underline{\hspace{4cm}}$$

Questions

1. What effect are the following factors likely to have on the accuracy of your determination of J_e , the Electrical Equivalent of Heat? Can you estimate the magnitude of the effects?
 - a. The inked water is not completely opaque to visible light.
 - b. There is some transfer of thermal energy between the EEH Jar and the room atmosphere. (What is the advantage of beginning the experiment below room temperature and ending it an equal amount above room temperature?)
2. How does J_e compare with J , the mechanical equivalent of heat. Why?
3. How do you determine the light efficiency of incandescent lamp?

Physics Laboratory Manual

b) Efficiency of Incandescent lamp:

Repeat Experiment 1, except do not use the India ink (step 4) and the styrofoam Calorimeter (step 7). Record the same data as in Experiment 1, and use the same calculations to determine E and H. (Convert H to Joules by multiplying by J_e from the first part.)

In performing the experiment with clear water and no Calorimeter, energy in the form of visible light is allowed to escape the system. However, water is a good absorber of infrared radiation, so most of the energy that is not emitted as visible light will contribute to H, the thermal energy absorbed by the water.

The efficiency of the lamp is defined as the energy converted to visible light divided by the total electrical energy that goes into the lamp. By making the assumption that all the energy that doesn't contribute to H is released as visible light, the equation for the efficiency of the lamp becomes:

$$\text{Efficiency} = (E - H_j)/E.$$

Data

$T_r =$ _____

$M_j =$ _____

$M_{jw} =$ _____

$V =$ _____

$I =$ _____

$t_i =$ _____

$t_f =$ _____

$T_i =$ _____

$T_f =$ _____

Calculations

In order to determine the efficiency of the lamp, it is necessary to determine both the total electrical energy that flowed into the lamp (E) and the total heat absorbed by the water (H).

E, the electrical energy delivered to the lamp:

$E = \text{Electrical Energy into the Lamp} = V \cdot I \cdot t =$ _____

$t = t_f - t_i = \text{the time during which power was applied to the lamp} =$ _____

H, the heat transferred to the water (and calorimeter):

Physics Laboratory Manual

$$H = (M_w + M_e)(1 \text{ cal/gm C})(T_f - T_i) = \underline{\hspace{10cm}}$$

$$M_w = M_{jw} - M_j = \text{Mass of water heated} = \underline{\hspace{10cm}}$$

$$H_j = H J_e = \underline{\hspace{10cm}}$$

$M_e = 23$ grams. Some of the heat produced by the lamp is absorbed by the EEH Jar. For accurate results, therefore, the heat capacity of the jar must be taken into account (The heat capacity of the EEH Jar is equivalent to that of approximately 23 grams of water.)

Efficiency:

$$(E - H_j)/E = \underline{\hspace{10cm}}$$

Questions:

1. What effect are the following factors likely to have on the accuracy of your determination of the efficiency of the lamp? Can you estimate the magnitude of the effects?
 - a. Water is not completely transparent to visible light.
 - b. Not all the infrared radiation is absorbed by the water.
 - c. The styrofoam Calorimeter was not used, so there is some transfer of thermal energy between the EEH Jar and the room atmosphere.
2. Is an incandescent lamp more efficient as a light bulb or as a heater?

EXPERIMENT NO. 04

Aim of the experiment: To determine the wavelength of sodium lines by Newton's rings method.

Apparatus required : An optical arrangement for Newton's rings with a plano-convex lens of large radius of curvature (nearly 100 cm) and an optically plane glass plate, convex lens, sodium light source, Traveling microscope, magnifying lens, reading lamp and spherometer

Description of apparatus : The experimental apparatus for obtaining the Newton's rings is shown in the Figure 1. A Plano-convex lens L of large radius of curvature is placed with its convex surface in contact with a plane glass plate P. At a suitable height over this combination, is mounted a plane glass plate G inclined at an angle of 45 degrees with the vertical. This arrangement is contained in a wooden box. Light from a board monochromatic sodium source rendered parallel with the help of convex lens L_1 is allowed to fall over the plate G, which partially reflects the light in the downward direction. The reflected light falls normally on the air film enclosed between the plano-convex lens L, and the glass plate P. The light reflected from the upper the lower surfaces of the air film produce interference fringes. At the center the lens is in contact with the glass plate and the thickness of the air film is zero. The center will be dark as a phase change of π radians is introduced due to reflection at the lower surface of the air film (as the refractive index of glass plate P ($n = 1.5$) is higher than that of the air film ($n = 1$)). So this is a case of reflection by the denser medium. As we proceed outwards from the center the thickness of the air film gradually increase being the same all along the circle with center at the point of contact. Hence the fringes produced are concentric, and are localized in the air film (Figure 2). The fringes may be viewed by means of a low power microscope (travelling microscope) shown in the Figure 1.

Working principle : When a plano-convex lens of large radius of curvature is placed with its convex surface in contact with a plane glass plate P a thin wedge shaped film of air is enclosed between the two. The thickness of the film at the point of contact is zero and gradually increases as we proceed away from the point of contact towards the periphery of the lens. The air film thus possesses a radial

Physics Laboratory Manual

symmetry about the point of contact. The curves of equal thickness of the film will, therefore, be concentric circles with point of contact as the center (Fig. 2).

In figure 3 the rays BC and DE are the two interfering rays corresponding to an incident ray AB. As Newton's rings are observed in the reflected light, the effective path difference x between the two interfering rays is given by:

$$x = 2t \cos \theta + \frac{\lambda}{2} \quad (10.1)$$

Where t is the thickness of the air film at B and θ is the angle of film at that point. Since the radius of curvature of the Plano-convex lens is very large, the angle θ is extremely small and can be neglected. The term $\lambda/2$ corresponds to phase change of π radians introduced in the ray DE due to reflection at the denser medium (glass). For air the refractive index (μ) is unity and for normal incidence, angle of refraction is zero. So the path difference x becomes:

$$x = 2t + \frac{\lambda}{2} \quad (10.2)$$

At the point of contact the thickness of the film is zero, i.e., $t = 0$, So $x = \lambda/2$. And this is the condition for the minimum intensity. Hence the center of the Newton's rings is dark. Further, the two interfering rays BC and DE interfere constructively when the path difference between the two is given by

$$x = 2t + \frac{\lambda}{2} = n\lambda \quad (10.3)$$

Or

$$2t = (2n - 1) \frac{\lambda}{2} \text{ [Maxima]} \quad (10.4)$$

And they interference destructively when the path difference

$$x = 2t + \frac{\lambda}{2} = (2n + 1) \frac{\lambda}{2} \text{ [Minima]} \quad (10.5)$$

Physics Laboratory Manual

From these equations it is clear that a maxima or minima of particular order n will occur for a given value of t . Since the thickness of the air film is constant for all points lying on a circle concentric with the point of contact, the interference fringes are concentric circles. These are also known as fringes of equal thickness.

Experimental Methods

Calculation of diameters rings:

Let r_n be the radius of Newton's ring corresponding to a point B, where the thickness of the film is t , let R be the radius of curvature of the surface of the lens in contact with the glass plate P, then from the triangle CMB (Figure 4), we have:

$$R^2 = r_n^2 + t^2, \text{ or } r_n^2 = 2Rt - t^2 \quad (10.6)$$

Since t is small as compared to R , we can neglect t^2 and therefore

$$r_n^2 = 2Rt, \text{ or } 2t = r_n^2 / R \quad (10.7)$$

If the point B lies over the n^{th} dark ring then substituting the value of $2t$ from equation (4) we have,

$$\frac{r_n^2}{R} = \frac{\lambda n}{2}, \text{ or } r_n^2 = \frac{\lambda n R}{2} \quad (10.8)$$

If D_n is the diameter of the ring then,

$$D_n^2 = 4r_n^2 \quad (10.9)$$

Similarly, if the point B lies over a n^{th} order bright ring we have

$$D_n^2 = 2\lambda n R \quad (10.10)$$

Calculation of λ :

Physics Laboratory Manual

From equation (7), if D_{n+p} is the diameter of $(n+p)^{\text{th}}$ bright ring, we have

$$= 2[2(n + 2) - 1] \tag{10.11}$$

Subtracting equation (7), from equation (8), we get:

$$- = 4 \tag{10.12}$$

$$\underline{\quad} = \tag{10.13}$$

By measuring the diameters of the various bright rings and the radius of curvature of the plano convex lens, we can calculate λ from the equation 9.

Formula used

The wavelength λ of the sodium light employed for Newton's rings experiments is given by:

$$= \frac{-}{4}$$

Where D_{n+p} and D_n are the diameter of $(n+p)^{\text{th}}$ and n^{th} bright rings respectively, p being an integer number. R is the radius of curvature of the convex surface of the plano-convex lens.

Methodology

1. Level the travelling microscope table and set the microscope tube in a vertical position. Find the vernier constant (least count) of the horizontal scale of the traveling microscope.

2. Clean the surface of the glass plate P, the lens L and the glass plate G. Place them in position a shown in Figure 1 and as discussed in the description of apparatus. Place the arrangement in front of a sodium lamp so that the height of the center of the glass plate G is the same as that of the center of the sodium lamp. Place the sodium lamp in a wooden box having a hole

Physics Laboratory Manual

such that the light coming out from the hole in the wooden box may fall on the Newton's rings apparatus and adjust the lens L_1 in between of the hole in wooden box and Newton's rings apparatus and adjust the lens L_1 position such that a parallel beam of monochromatic sodium lamp light is made to fall on the glass plate G at an angle of degrees.

3. Adjust the position of the travelling microscope so that it lies vertically above the center of lens L . Focus the microscope, so that alternate dark and bright rings are clearly visible.
4. Adjust the position of the travelling microscope till the point of intersection of the cross wires (attached in the microscope eyepiece) coincides with the center of the ring system and one of the cross-wires is perpendicular to the horizontal scale of microscope.
5. Slide the microscope to the left till the cross-wire lies tangentially at the center of the 20th dark ring (see Figure). Note the reading on the vernier scale of the microscope. Slide the microscope backward with the help of the slow motion screw and note the readings when the cross-wire lies tangentially at the center of the 18th, 16th, 14th, 12th, 10th, 8th, 6th and 4th dark rings respectively [Observations of first few rings from the center are generally not taken because it is difficult to adjust the cross-wire in the middle of these rings owing to their large width].
6. Keep on sliding the microscope to the right and note the reading when the cross-wire again lies tangentially at the center of the 4th, 6th, 8th, 10th, 12th, 14th, 16th, 18th, 20th dark rings respectively.
7. Remove the plano-convex lens L and find the radius of curvature of the surface of the lens in contact with the glass plate P accurately using a spherometer. The formula to be used is :

$$\frac{1}{R} = \frac{1}{r_1} + \frac{1}{r_2} \quad (10.14)$$

Physics Laboratory Manual

where l is the mean distance between the two legs of the spherometer h is the maximum height of the convex surface of the lens from the plane surface.

1. Find the diameter of the each ring from the difference of the observations taken on the left and right side of its center. Plot a graph between the number of the rings on X-axis and the square of the corresponding ring diameter on Y-axis. It should be a straight line as given by the equation 9 (see figure). Taken any two points on this line and find the corresponding values of (–) and p for them.
2. Finally calculate the value of wavelength of the sodium light source using the formula.

Observations

Determination of the Least Count:

Determination of the Least Count of the Horizontal Scale of travelling Microscope

1. Value of one division of the horizontal main scale of travelling microscope = cm
 2. Total number of divisions on the Vernier scale = which are equal to division of main scale of the Vernier scale =cm
 3. Value of one division of the Vernier scale =cm
 4. Least count of the horizontal scale of the microscope (given by the value of one division of main scale – the value of one division of Vernier scale)=
 5. Pitch of the screw =cm
1. Number of division on circular head =
 2. Least count of the spherometer =cm
 3. Mean distance between the two legs of the spherometer, l =cm

Physics Laboratory Manual

4. The radius of curvature R of the plano convex lens is (as given by equation 10):

$$= [\quad / (6h + h)/2] = \dots\dots\dots \text{cm}$$

5. The wavelength λ of sodium light is (as given by equation 9):

$$= \frac{\quad - \quad}{4}$$

Calculations from the graph:

1. Plot a graph taking squares of the diameters, $(a-b)^2$ along the Y-axis and the number of rings along the X-axis (See Figure).
2. The curve should be a straight line.
3. Take two points P_1 and P_2 on this line and find the corresponding values of $(\quad - \quad)$ and p from it, calculate the value of wavelength of the sodium light from these values.

Table 10.1: Determination of $(\quad - \quad)$ and p

Order of The Rings	Reading of the microscope left hand side (a) cm	Right hand side (b) cm	Diameter of the ring ($a-b$) cm	Diameter $(a-b)^2$ cm ²	($\quad^2 - \quad^2$), for $p=4$ cm ²	Mean value of $(\quad^2 - \quad^2)$, for $p=4$ cm ²
20					20 16	
18					18 14	

Physics Laboratory Manual

16					16	12	
14					14	10	
12					12	8	
10					10	6	
8					8	4	

Table 10.2: Determination of R (radius of curvature of the lens L) using a spherometer

SI No	Spherometer reading on		h (a~b) cm	Mean h cm
	Plane glass plate a cm	Convex surface of lens b cm		

Results

The value of the wavelength of the sodium light as calculated

1. Using the observations directly =Å

2. Using the graphical calculations = Å

Physics Laboratory Manual

3. Mean value of the wavelength of sodium light = Å
4. Standard average value of the wavelength of the sodium light = 5893 Å
5. Percentage of error =%

Source of errors and precautions:

1. The optical arrangements as shown in Figure 1 should be very clean (use spirit for cleaning these optical elements) and so made that the beam of light falls normally on the plano-convex lens L and glass plate P combinations.
2. The plano-convex lens for the production of Newton's rings should have large value of radius of curvature. This will keep the angle of wedge shape air film very small and therefore the rings will have a larger diameter and consequently the accuracy in the measurements of the diameter of the rings will be increased.
3. To avoid any backlash error, the micrometer screw of the travelling microscope should be moved very slowly and moved in one direction while taking observations.
4. While measuring diameters, the microscope cross-wire should be adjusted in the middle of the ring.
5. The amount of light from the sodium light should be adjusted for maximum visibility. Too much light increases the general illumination and decrease the contrast between bright and dark rings.

Sample oral questions:

Physics Laboratory Manual

1. What do you understand by the interference of light?
2. What are essential conditions for obtaining interference of light?
3. What do you understand by coherent source?
4. Is it possible to observe interference pattern by having two independent sources such as two candles?
5. Why should be two sources be monochromatic?
6. Why are the Newton's rings circular?
7. Why is central ring dark?
8. Where are these rings formed?
9. Sometimes these rings are elliptical or distorted, why?
10. What is the difference between the rings observed by reflected light and those observed by transmitted light?
11. What will happen if the glass plate is silvered on the front surface?
12. What will happen when a little water is introduced in between the plano-convex lens and the plate?
13. How does the diameter of rings change on the introduction of liquid?
14. Can you find out the refractive index of a liquid by this experiment?
15. Is it possible to have interference with a lens of small focal length?
16. What will happen if the lens is cylindrical?
17. Why do the rings get closer and finer as we move away from the center?

EXPERIMENT NO . 05

Aim of the experiment: To determine the frequency of electrically maintained tuning fork by Melde's experiment.

Apparatus required: Electrically maintained tuning fork, Light weight pan, Weight box, Analytical balance, Power supply, Light weight string, Stand with clamp and pulley.

Theory:

1. *Standing waves in strings and normal modes of vibration:*

When a string under tension is set into vibrations, transverse harmonic waves propagate along its length. The speed of the wave in the stretched string depends on the tension in the string and mass per unit length of the string and is given by:

$$v = \sqrt{\frac{T}{\mu}}$$

where T is the tension in the string which is equal to mg . m is the mass suspended on the string and g is the acceleration due to gravity and μ is the mass per unit length of the string, given by $\mu = \frac{M}{L}$ (1)

M is the mass of the string and L is the total length of the string.

A string can be set into vibrations by means of an electrically maintained tuning fork. When the other end of the string is clamped to a rigid support (pulley in present case), reflected waves will also exist. The incident and reflected waves will superimpose to produce transverse stationary waves in the string. The string will vibrate in such a way that the clamped points of the string are nodes and the anti-node exists at the middle.

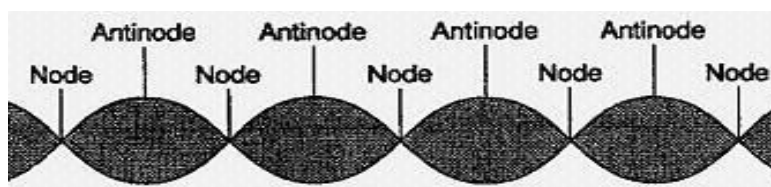

Figure 1. Schematic representation of standing waves showing nodes and antinodes.

Physics Laboratory Manual

The loops are formed from the end of the rigid support where it touches the pulley to the position where it is fixed to the prong of tuning fork. If l is the length of the string between two successive nodes, then

$$l = \frac{\lambda}{2} \quad (2)$$

where, λ is the wavelength of the traversing wave. The frequency (f) of the vibration is given by

$$f = \frac{v}{\lambda} = 2 \quad (3)$$

substituting the value of l from Eq. (1), we get

$$f = \frac{v}{2l} = \frac{v}{2} \quad (4)$$

2. Transverse mode arrangement:

In this arrangement, the vibrations of the prongs of the tuning fork are in the direction perpendicular to the length of the string. The experimental setup with transverse mode arrangement is shown in Figure 2.

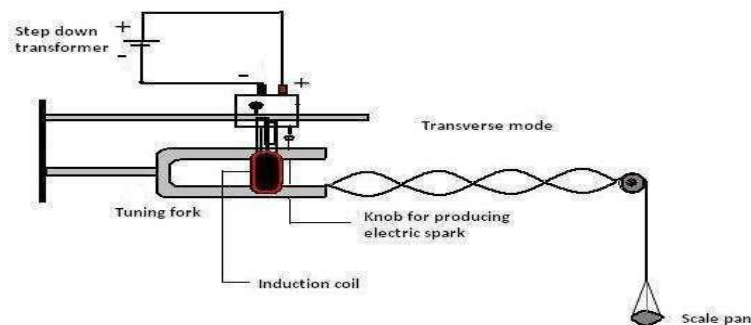

Figure 2: Experimental setup with tuning fork in transverse mode arrangement.

In transverse mode, the string also completes one vibration when the tuning fork completes one. Hence in this mode, frequency of the tuning fork is equal to the frequency of the string which is same as Eq. 4.

$$= \frac{1}{2} = \frac{1}{2} \quad (5)$$

where, m is the mass suspended on the string. $M = m + M'$ is the mass of the weights placed on the scale pan and M' is the mass of the scale pan attached to the string. If n loops are formed in length l (between two fixed ends) of the thread, then $\lambda = l/n$. Thus, Eq. 5 can also be expressed as,

$$= \frac{1}{2} \quad (6)$$

3. Longitudinal mode arrangement:

In this arrangement, the tuning fork is set in such a manner that the vibrations of the prongs are parallel to the length of the string. The experimental setup with longitudinal mode arrangement is shown in Figure 3.

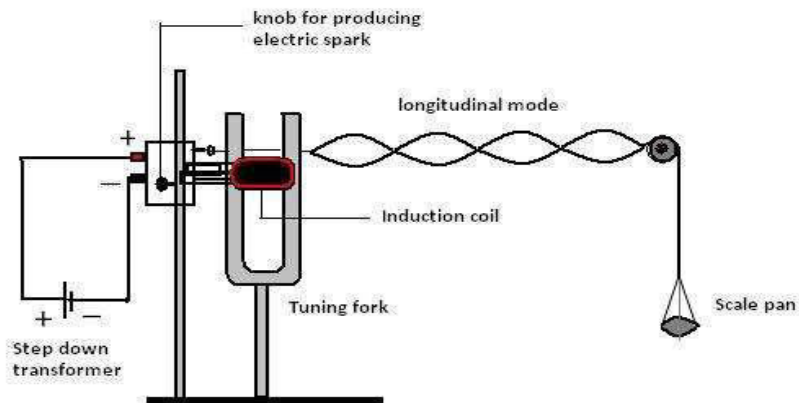

Figure 3: Experimental setup with tuning fork in longitudinal mode arrangement.

Physics Laboratory Manual

In longitudinal mode, the string completes half of its vibration when the tuning fork completes one. Hence in this mode, frequency of the tuning fork is double the frequency of the string and is given as

$$= \frac{v}{2L} \quad (7)$$

Procedure:

1. Find the mass of the scale pan ' ' and arrange the apparatus as shown in figure.
2. Excite the tuning fork by switching on the power supply (advisable to use voltage more than 6V)
3. Adjust the position of the pulley in line with the tuning fork.
4. Change the load in the pan attached to the end of the string.
5. Adjust the applied voltage so that vibrations and well defined loops are obtained.
6. The tension in the string increases by adding weights in the pan slowly and gradually. For finer adjustment, add milligram weight so that nodes are reduced to points at the edges.
7. Count the number of loop and the length of each loop. For example, if 4 loops formed in the middle part of the string. If ' ' is the distance in which 4 loops are formed, then distance between two consecutive nodes is $l/4$.
8. Note down the weight placed in the pan and calculate the tension .
9. Tension, $T = (\text{wts. on the pan} + \text{wt. of pan}) \cdot g$.
10. Repeat the experiment for longitudinal and transverse mode of vibrations.
11. Measure one meter length of the thread and find its mass to find the value of mass produced per unit length (μ).

Observations and calculations:

Mass of the pan, ' ' =..... gm

Mass per unit length of the string,

=..... gm/cm

For transverse mode arrangement:

Physics Laboratory Manual

Frequency

$$= \frac{\text{---}}{2 \text{ ---}} \quad (8)$$

Table-1: Frequency of transverse mode arrangement

S.No.	Weight () gm	No. of loops ()	Length of thread () cm	Length of each loop (/) cm	Tension () (+) gm	Frequency () Hz
1						
2						
3						

Mean frequency= ----- Hz

For longitudinal mode arrangement

$$\text{---}$$

Frequency = ----- (9)

Table-2: Frequency of longitudinal mode arrangement

S.No.	Weight (W) gms	No. of loops (P)	Length of thread (L) cms	Length of each loop (L/P) cms	Tension (T) (W+w) gms	Frequency (f) Hzs
1						
2						
3						

Mean frequency= ----- Hz

Precautions:

1. The thread should be uniform and inextensible.
2. Well defined loops should be obtained by adjusting the tension with milligram weights.
3. Frictions in the pulley should be least possible.

EXPERIMENT NO. 06

Aim of the experiment: Measurement of voltage and frequency of a given signal using CRO

Apparatus Required: Cathode Ray Oscilloscope, Function Generator(s), a pair of BNC Connectors

Introduction: A cathode ray oscilloscope (CRO) can be used to measure the voltage and frequency of given unknown signal. (A brief description of CRO is given at the end of this manual). A RC oscillator can be used to generate an electrical signal of desired frequency and amplitude. In the given experiment the RC oscillator has to be used to generate the signal and the CRO will be used to measure its voltage and frequency.

Procedure: Switch on the oscillator. Place the time base knob in horizontal input position and wait for a couple of minutes. Notice a bright spot of light on the screen of the CRO. You can move the spot in vertical or horizontal direction by using the horizontal position knob and vertical position knob respectively. Place the time base in appropriate position (i.e. 1ms/cm or 0.1 ms/cm or any other value). You will notice a bright line on the CRO screen. Your CRO is now ready to measure voltage and frequency of the unknown signal.

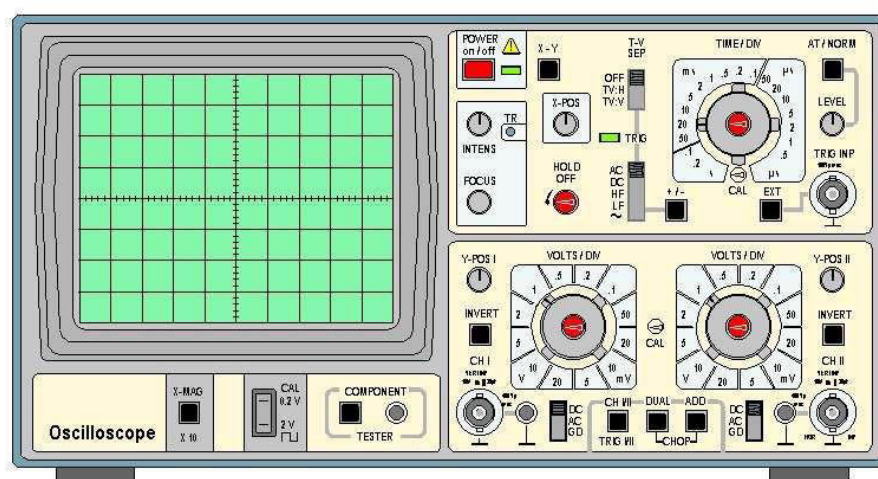

Figure 1: The Cathode ray oscilloscope used in Physics Laboratory.



Figure 2: The function generator used in Physics Laboratory.

Selection of frequency:

The RC oscillator is having several knobs, which can be used to select frequency of the signal to be generated. In the top left hand corner you would see three knobs. These knobs can be used to select frequency value, which can be represented by three digits. For example, suppose you are setting the left knob to 6, the middle knob to 5 and the extreme right knob to 4. Then the selected frequency will be 654Hz. below these three knobs you will get a multiplier. The multiplier will multiply the above selected frequency. Thus if you select 654Hz and multiplier position is 10 then the overall frequency will be 6540Hz.

Selecting amplitude of the signal:

The RC oscillator provides you option to vary the voltage of the signal to be generated. This can be done using two voltage selecting knobs (Fine and Coarse). Therefore, using different knobs a signal of given amplitude and given frequency can be generated by the RC oscillator. This signal can now be used as an input to the CRO and its frequency and voltage can be measured.

Voltage Measurements:

Physics Laboratory Manual

Use the signal generated by RC oscillator as an input to CRO. Place the Y amplifier in proper value. From vertical scale measure the peak to peak value. This will give the value of peak to peak voltage of the signal.

Lissajous Figures:

Theory:

When two simple harmonic motions are plotted against each other at right angles, the resulting configuration is called a Lissajous figure. Simple harmonic motions plotted against time gives sinusoidal configurations. Two sinusoidal electrical inputs given to an oscilloscope will give a Lissajous pattern on the screen. The particular pattern depends upon the frequency, amplitude and phase of the applied inputs. The frequency ratio of the inputs may be determined from an analysis of the Lissajous figure produced. If a Lissajous figure is enclosed in a rectangle whose sides are parallel to the formation axes of the figure, the frequency ratio of the two inputs may be determined by counting the points of tangency to the sides of the rectangle enclosing the pattern. Once the frequency ratio is known, the input frequency can also be determined from the same.

Procedure:

1. Connect one signal generator to the vertical input and the other to the horizontal input of the oscilloscope. Switch controls so that the oscilloscope accepts the output of the signal generator instead of the horizontal sweep. Set both the generators for 1000 cycles (say) and make gain adjustments until an ellipse of satisfactory size is observed on the screen. Adjust controls as necessary to stop the ellipse. By switching one of the generators off and on, cause the ellipse to change phase, noting the various shapes it assumes. By phase changes and amplitude adjustments, one may try to get a circular configuration.
2. Leaving the vertical input at 1000 cycles and assuming it to be the standard, adjust the horizontal input generator (the variable) approximately 500 c.p.s. to obtain the 1-2 Lissajous figure, a figure 8 on its side.
3. Next obtain the 2:1 pattern by varying the horizontal input frequency. This is an upright figure 8.

4. In like manner, obtain Lissajous figures down to 1:5 and upto 5:1. Sketch all the figures obtained and compare the frequency. Obtained from the Lissajous ratios with the dial reading of the horizontal input signal generator.

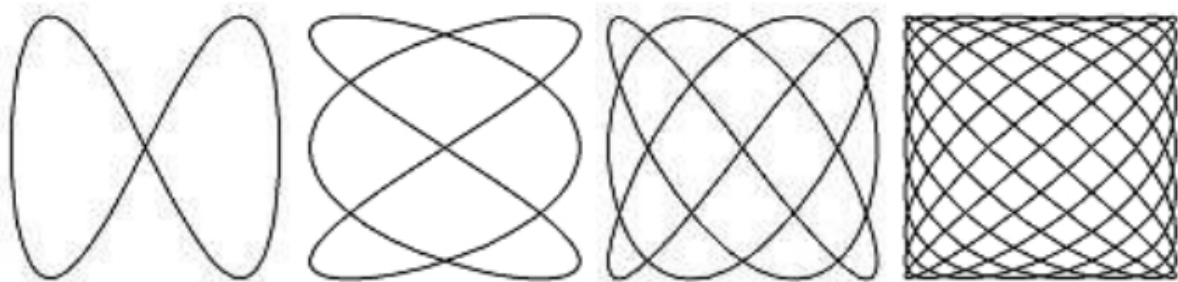

Figure 3: Sample Lissajous Figures

5. Now, remove one signal generator from the oscilloscope and connect the given unknown source. Changing the frequency of the signal generator, various Lissajous figures may be obtained (e.g. circle, 8 shape, etc.). Hence, from the known ratio of the respective Lissajous figures, the frequency of the AC source can be measured.

Observation Table:

Table 1: Measurement of voltage by CRO

Sl. No.	Voltage from Source	RMS voltage V_{rms} measured by FG (V)			Ratio of V_{p-p}/V_{rms}
		Y-amplifi setting (V/div)	Vertical scale No of div.	V_{p-p} (V)	

Physics Laboratory Manual

Table 2: Measurement of frequency

Sl. No.	Freq. of function generator (f in Hz)			Freq. measurement using CRO (f_o in Hz)			Ratio f/f_o
	Digits	Multiplier	f (in Hz)	Value of time base	No. of div.	f_o (in Hz)	

Horizontal input Frequency on dial	Shape of figure	No. of tangency Points on X-axis on Y-axis	Vertical/Horizontal	Vertical Frequency

Precautions: The precautions to be taken while performing the experiment are:

1. Correct output/input terminals of function generators and CRO should be chosen.
2. Make sure that correct types of wave output have been chosen from function generator (Sine or Triangular or Square or DC)
3. Don't crank up the voltage level from function generator at its maximum limit.
4. The image produced over the CRO screen should be sharp and as thin as possible to take the correct readings.

EXPERIMENT NO. 07

Aim of the experiment: To determine the emf of an unknown cell using a stretched wire potentiometer.

Apparatus required: Stretched wire potentiometer, jockey, galvanometer, Power source, Cell (Leclanché), Standard cell, rheostat, resistance box, connecting wires, plug and key.

Theory: If a current i flows through the potentiometer wire of L cms and Resistance R_p ohms. If R is the series resistance series with the potentiometer then

$$E = \frac{R_p}{R + R_p} \times \text{---} \quad (1)$$

Where E is the e.m.f of the cell C . The potential drop across the end of the potentiometer wire is

$$V = \frac{R_p}{L} \times \text{---} \quad (2)$$

Hence the potential drop per the centimeter of the wire is

$$\frac{V}{L} = \frac{R_p}{L} \times \text{---} \times \text{---} \text{ volts} \quad (3)$$

If cell C_1 and C_2 are the required length l_1 and l_2 for the potentiometer wire for balance then the e.m.f. E_1 and E_2 of the cells C_1 and C_2 are given by

$$E_1 = \frac{l_1}{L} \times \text{---} \times \text{---} \text{ volts} \quad (4)$$

$$E_2 = \frac{l_2}{L} \times \text{---} \times \text{---} \text{ volts} \quad (5)$$

The ratio of emf of two cell is

$$\frac{E_1}{E_2} = \frac{l_1}{l_2} \quad (6)$$

The e.m.f. of single cell is given by

$$E_1 = \frac{r_1}{r_2} \times E_2 \quad (7)$$

By simply determining the balancing length emf of unknown cell can be calculated from the above equation.

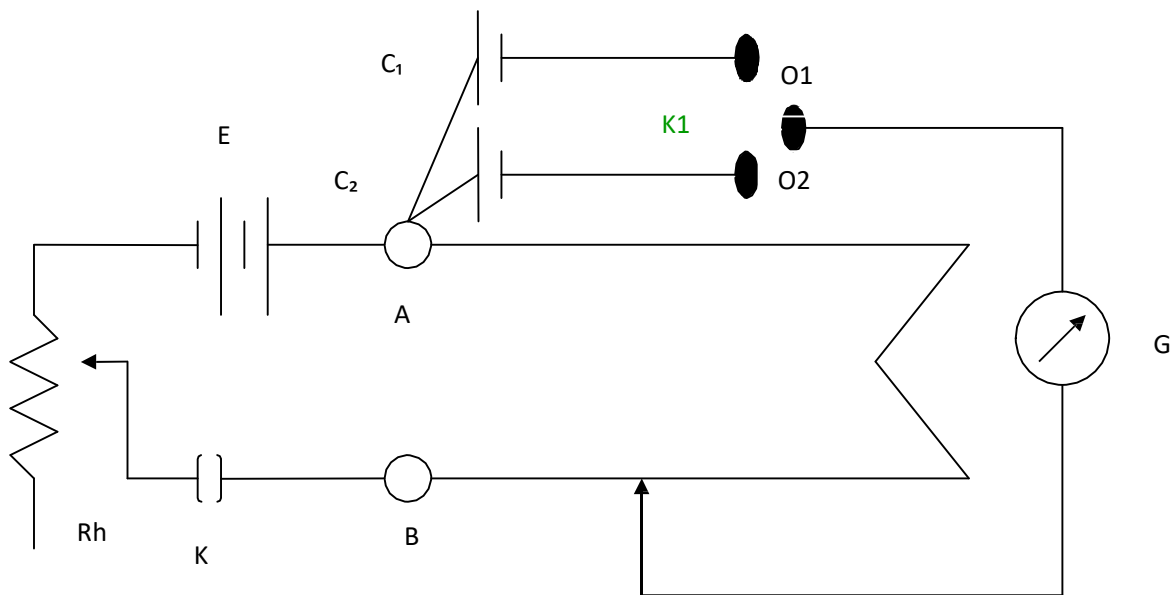

Figure 1: Circuit diagram to determine the emf of an unknown cell

Procedure:

1. Connect as if Fig 1. Connect the positive terminal of the power supply to the end A of the potentiometer wire and the negative through the rheostat
2. Connect the positive terminal of two cells C_1 and C_2 to A and negative terminals to the binding screws O_1 and O_2 of the two way key K_1 .
3. Join the third binding screw to one terminal of the galvanometer to the jockey J.
4. Make the resistance R_h zero and resistance R maximum. Put the jockey J in contact with the first and last. If the galvanometer deflection is **opposite** then the connection for C_1 is correct.
5. Repeat the process for Cell C_2

Physics Laboratory Manual

6. After verifying the deflection find the null point for both C_1 and C_2
7. If the length for C_1 is greater than that of C_2 then the emf for E_1 is greater than emf for E_2 for C_2 .
8. Adjust the rheostat for different values and take the reading

Observation:

No. of obs.	Cell	Null points			Total length in (cm)	$E_1/E_2 = l_1/l_2$	Mean E_1/E_2
		Wire number (cm)	Scale reading (cm)	Mean scale reading (cm)			
1	First (E_1)	10th	 = (x_1)	$900+x_1$		
	Second (E_2)						
2	First (E_1)	9th	 = (x_3)	$800+x_3$		
	Second (E_2)						
3	First (E_1)	10th	 = (x_5)	$900+x_1$		
	Second (E_2)						

The e.m.f. of an unknown cell is calculated by

$$E_1 = \frac{l_1}{l_2} \times E_2 \quad (8)$$

Result & Discussion:

Precautions:

1. All the connection terminals should be clean and tight.
2. Jockey should be held vertical.
3. All the keys should remain open and may be closed a short while before taking the readings.

EXPERIMENT NO. 08

Aim of the experiment: Determination of refractive Index of the material of a Prism using Spectrometer and Sodium Light.

Apparatus required: Source of light (Sodium Vapor/Mercury lamp), Spectrometer, Prism, Spirit level.

Description: Prism is a portion of refracting material bounded by three planes. A cross-section of prism by a horizontal plane is triangular in form. Each of the three faces is called refracting faces. The line in which two refracting meet each other is called refracting edge.

Theory: A ray of light EF incident on one of the refracting faces get refracted along the path FG through the prism and emerges along the path GH as shown in the fig.1. The angle between produced incident ray and emergent ray is called angle of deviation D . For refraction through a prism,

$$i + A = e + D$$

Where i & e are the angle of incidence and angle of emergence respectively. A being the angle of prism and D is the angle of deviation.

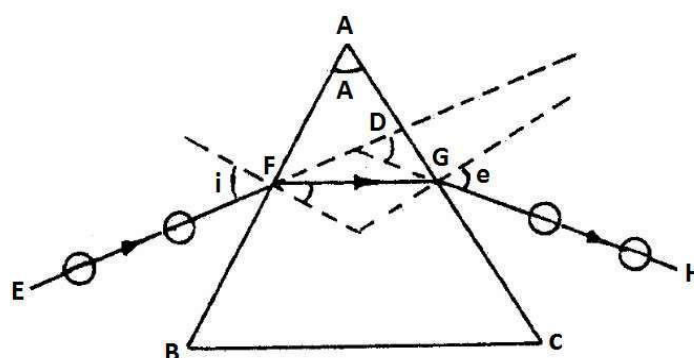

Figure-1 Ray diagram of Sodium light through prism

Physics Laboratory Manual

Angle of deviation D depends upon the angle of incidence i . For certain angle of incidence, deviation is minimum. It is denoted by D_m . Refractive index of material of the prism (μ) is related to the angle of prism A and the angle of minimum deviation D_m through the relation.

$$\mu = \frac{\sin \frac{A + D_m}{2}}{\sin \frac{A}{2}}$$

Where, μ = refractive index of the material of the prism.

A = angle of the prism

D_m = angle of minimum deviation

When the prism at minimum deviation position, angle i = angle e and angle of refraction at both surface; $r_1 = r_2$

From $D = i + e - A$

$$D_m = i + e - A$$

$$D_m = 2i - A$$

or, $2i = D_m + A$

$$i = \frac{D_m + A}{2}$$

$$\& e = \frac{D_m + A}{2}$$

Procedure: Measurement of refractive index of material of the prism consists of two parts . . .

- A. Determination of the angle of prism A .
- B. Determination of angle of minimum deviation . . .

Measurement of the angle of minimum deviations:

1. Place the prism so that its center coincides with the center of the prism table and light falls on one of the polished faces and emerges out of the other polished face, after refraction. In this position the spectrum of light is obtained.
2. The emergent ray is seen through the telescope and the telescope is adjusted for minimum deviation position (wavelength) in the following way: Set up the telescope at an imaginary position and rotate the prism table in one direction along with the telescope in such a way to keep the spectral line in view. By doing so a position will come where a spectral line recede in opposite direction although the rotation of the table is continued in the same direction. The particular position where the spectral line begins to recede in opposite direction is the minimum deviation position for that colour. Note the readings of two verniers. While rotating the prism table note down the different angles from the vernier and read as angle of deviation and calculate the angle of incidence using the equation $i = \frac{D_m}{2} + \frac{A}{2}$.
3. If polychromatic light is used repeat the above procedure for all wavelength(color)
4. Remove the prism table and bring the telescope in the line of the collimator. See the slit directly through telescope and coincide the image of slit with vertical crosswire. Note the readings of the two verniers.

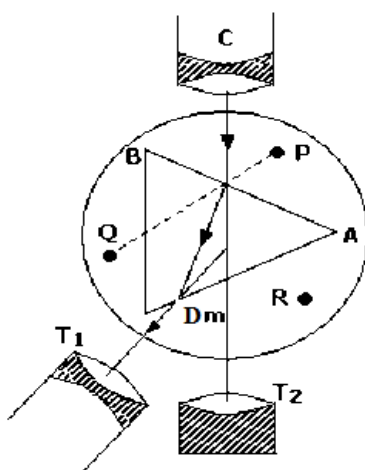

Figure-2 Ray diagram for determination of angle of minimum deviation

Physics Laboratory Manual

5. The difference in minimum deviation position and direct position gives the angle of minimum deviation (D_m).
6. The same procedure is repeated to obtain the angles of minimum deviation for all colors if white light is used.

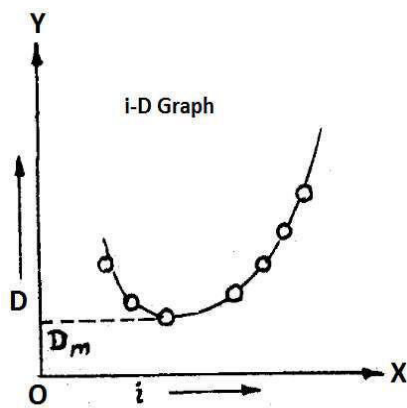

Figure-2 Graph of angle of deviation vs angle of incidence

7. Plot a graph (i vs D) taking angle of incidence i along the X-axis and angle of deviation D along the Y-axis. The nature of the graph is shown in fig.4.
8. Draw a horizontal line as a tangent to the lowest point of the curve. Intersection of this horizontal line on Y-axis gives the angle of minimum deviation (fig.4).

Observations:

The angle of given prism is 60

Table for the angle of minimum deviation ():

S.No.	Colour	Vernier	Telescope Reading for minimum deviation			Telescope Reading for direct image			Difference $D_m = a-b$	Mean Value of D_m
			MSR	VSR	TR(a)	MSR	VSR	TR(b)		
1.	Violet	V_1								
		V_2								

Physics Laboratory Manual

2.	Red	V ₁				
		V ₂				
3.	Yellow	V ₁				
		V ₂				

MSR = Main Scale Reading, VSR = Vernier Scale Reading, TR = MSR+VSR = Total Reading

Calculations: Putting the mean value of A from Table 1 and the angle of minimum deviation D_m from the graph, the refractive index of the material of the prism can be found out.

Result: Refractive Index for the material of the prism:

S.No.	Color	Calculated Refractive Index	Standard Refractive Index	%Error

Precautions and Sources of Error:

1. The telescope and collimator should be individually set for parallel rays.
2. Slit should be as narrow as possible.
3. While taking observations, the telescope and prism table should be clamped with the help of clamping screws.
4. Both verniers should be read.
5. The prism should be properly placed on the prism table for the measurement of angle of the prism as well as for the angle of minimum deviation.

EXPERIMENT NO: - 09

Aim of the experiment: To study the frequency response and quality factor of series LCR circuit.

Apparatus required: Cathode ray oscilloscope (CRO) with probe, Function generator, Inductor, Capacitor, decade resistance box, a $1k\Omega$ resistor, connecting wires with BNC and crocodile clip terminations.

Theory: If we apply a sinusoidal voltage to a series LCR circuit the net impedance offered by the circuit to the flow of current will be the vector sum of that offered by the resistive (frequency independent) part as well as the reactive (frequency dependent) part, i.e.

$$Z = R + j(X_L - X_C)$$

or, $Z = \sqrt{R^2 + (X_L - X_C)^2}$

or, $Z = \sqrt{R^2 + X^2}$

The current in the circuit is given by

$$I = \frac{V}{Z}$$

Or, $I = \frac{V}{\sqrt{R^2 + X^2}}$

by, and the phase angle between the applied voltage and the current through the circuit is given

Physics Laboratory Manual

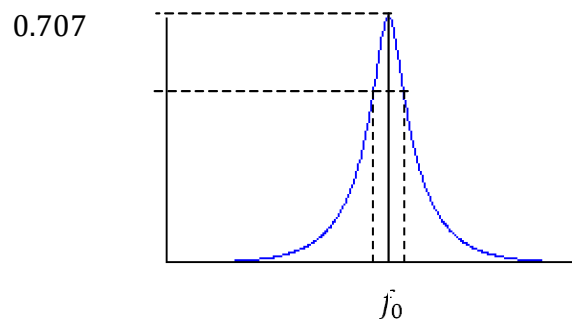
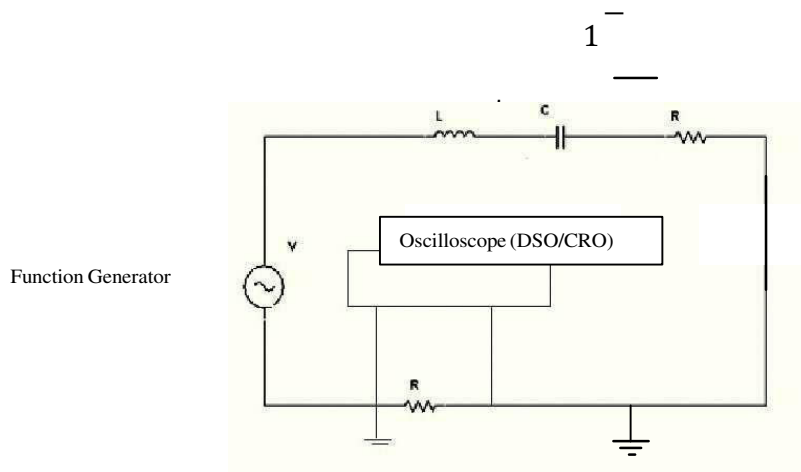

If the frequency () of applied voltage, matches the natural frequency (), of the circuit then the inductive reactance and the capacitive reactance equals each other i.e.,

$$= 1/$$

and the current in the circuit is solely decided by the value of R, i.e.,

$$=$$

Physics Laboratory Manual

The frequency at which the inductive reactance equals the capacitive reactance is the natural frequency or the resonant frequency of the circuit. The resonant frequency of an LCR circuit depends upon the values of L and C by the relation

$$= \frac{1}{\dots}$$

or,
$$= \frac{\dots}{\sqrt{\dots}}$$

The sharpness of resonance for a particular value of L and C depends upon the value of R and is computed from the plot of \dots versus \dots by the relation

$$= \frac{\dots}{\dots}$$

The 'Quality factor' or the 'Q factor' is a dimensionless parameter that describes how under-damped an oscillator or resonator is. Higher values of Q indicate lower rate of energy loss relative to the energy stored in the oscillator.

There are two separate definitions of the quality factor that are equivalent for high Q resonators but are different for strongly damped oscillators.

Generally Q is defined in terms of the ratio of the energy stored in the resonator to the energy being lost in one cycle:

$$= 2 \times \dots$$

The factor of 2π is used to keep this definition of Q consistent (for high values of Q) with the second definition:

Physics Laboratory Manual

$$= \frac{\Delta f}{f_0} = \frac{\Delta \omega}{\omega_0}$$

where, f_0 is the resonant frequency,

$$\Delta f \quad \Delta \omega$$

Δf is the bandwidth,

ω_0 is the angular resonant frequency, and

$\Delta \omega$ is the angular bandwidth.

The definition of Q in terms of the ratio of the energy stored to the energy dissipated per cycle can be rewritten as:

$$Q = \frac{\text{Energy stored}}{\text{Energy dissipated per cycle}} \times \omega$$

where, ω is defined to be the angular frequency of the circuit (system), and the energy stored and power loss are properties of a system under consideration.

Procedure:

1. Before making any connections (except mains power cords) switch on the oscilloscope and ensure that the sensitivity of the oscilloscope is set at a low value, for example 10V/div.
2. Switch on the function generator and adjust its voltage amplitude to a level $\leq 5V$ and let it remain constant throughout the experiment.
3. Also, make sure you are using a compatible probe with the CRO / DSO and function generator. Please note that the probes may appear similar but are not interchangeable.
4. Set the function generator in sinusoidal signal mode.
5. Connect the L, C, R and a $1K\Omega$ resistor in series and the two extreme ends to the function generator output through a BNC (as shown in figure).
6. Ensure that the $1K\Omega$ resistor is connected to the function generator output ground.
7. Connect the ground terminal of the oscilloscope probe to the ground of function generator, and the other terminal of the probe in such a way that the oscilloscope gets connected just across the $1k\Omega$ resistor as shown in the preceding circuit diagram.
8. Set $R=0$ from the resistance box.

Physics Laboratory Manual

9. Adjust the frequency output of the function generator to 10 Hz.
10. Record the voltage amplitude of the signal shown by the oscilloscope.
11. Go on incrementing the frequency logarithmically and record your observation, i.e., repeat step-9 till you reach 1MHz.
12. In next set of experiment increase R to $1\text{k}\Omega$ and repeat steps 8, 9 &10.
13. Once again increase R to $4\text{k}\Omega$ and repeat steps 8, 9 &10.
14. Current (in ampere) can be obtained by dividing the voltage amplitude by the resistor value (1000Ω in our case). Value of current in mA is numerically equal to the voltage amplitude itself as long as the value of resistor across the oscilloscope is maintained.

Observations:

L = 100mH

Frequency (Hz)	R = 0 Ω		R = 1k Ω		R = 4k Ω	
	V (volt)	I (mA)	V (volt)	I (mA)	V (volt)	I (mA)
100						
200						
..						
..						
900						
1k						
2k						
..						
..						
9k						
10k						
20k						
..						
..						

Physics Laboratory Manual

90k						
100k						

Plot: Plot the current versus frequency for the three resistor values (i.e., $0\ \Omega$, $1\ \text{k}\Omega$ and $4\ \text{k}\Omega$) on the same graph sheet neatly and mark the resonant frequency (), the peak amplitude and for each plot. Sketch a dotted horizontal line corresponding to $\frac{1}{\sqrt{2}}$ and mark that it cuts the plot at two points. Drop perpendiculars from these points on the axis and mark the lower cutoff and upper cutoff frequency points. Note that the gap between the cutoff frequencies widens as the value of R increases.

Calculations:

Calculating the value of capacitor

$$= \frac{1}{\dots}$$

Calculating quality factor (for different values of R)

$$= \frac{4}{\dots}$$

Result & discussion:

-

$\omega = 100\ \text{mH}$					
R	(Hz)	(μF)	(Hz)	(Hz)	
$0\ \Omega$					
$1\ \text{K}\Omega$					
$4\ \text{K}\Omega$					

Compare the resonant frequency and quality factors for the three resistor values. Comment on the results obtained by you.

EXPERIMENT NO. 10

Study of Lorentz force using Current Balance experiment, i.e to verify $F_m = IL \times B$

1. . Aim

To understand the working principle of current balance and to verify $F_m \propto I$, $F_m \propto L$ and $F_m \propto B$ under various conditions.

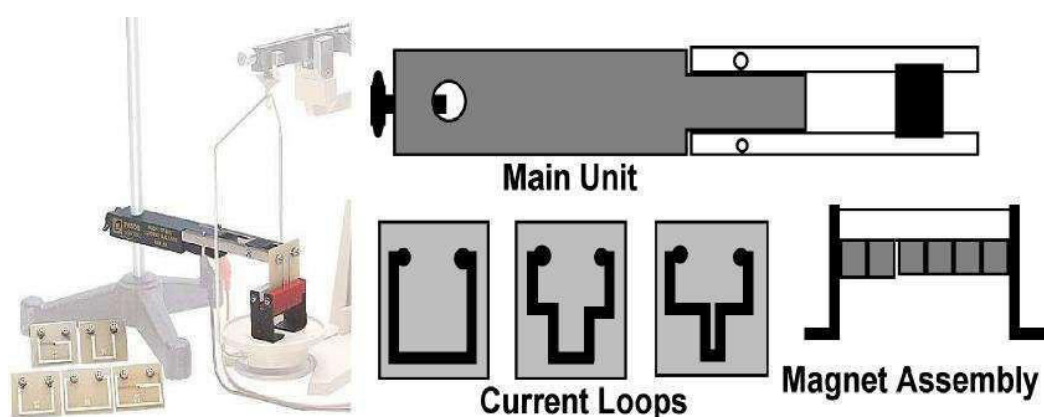

Figure 8.1: Experimental setup with accessories and schematic of the same.

2. Apparatus required

Current balance, permanent magnet, current loops, DC power supply

3. Theory

A current-carrying wire in a magnetic field experiences a force that is usually referred to as a magnetic force. The magnitude and direction of this force depend on four variables: the magnitude of the current (I); the length of the wire (L); the strength of the magnetic field (B); and the angle between the field and the wire (θ). This magnetic force can be described mathematically by the vector cross product:

$$F_m = IL \times B,$$

or in scalar terms, $F_m = ILB\sin(\theta)$.

4. Procedure

i. Part 1: Experiment of Force vs Current

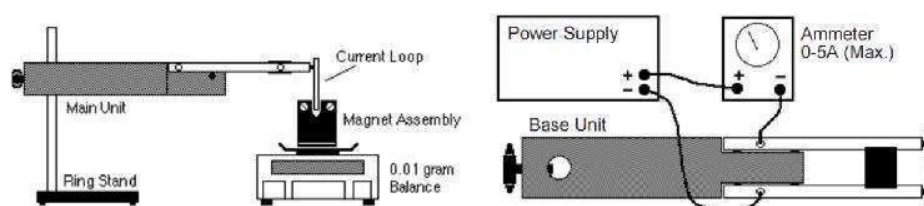

Figure 8.2: Experimental setup with accessories.

1. Set up the apparatus as shown in figure 8.2. Determine the mass of the magnet holder and magnets with no current flowing. Record this value in the column under “Mass” in Table.
2. Set the current to 0.5 amp. Determine the new “mass” of the magnet assembly. Record this value under “Mass” in Table 8.1.
3. Subtract the mass value with the current flowing from the value with no current flowing. Record this difference as the “Force.”
4. Increase the current in 0.5 amp increments to a maximum of 5.0 amp, each time repeating steps 2 - 3.
5. Plot a graph of Force (vertical axis) versus Current (horizontal axis).
6. What is the nature of the relationship between these two variables? What does this tell us about how changes in the current will affect the force acting on a wire that is inside a magnetic field?

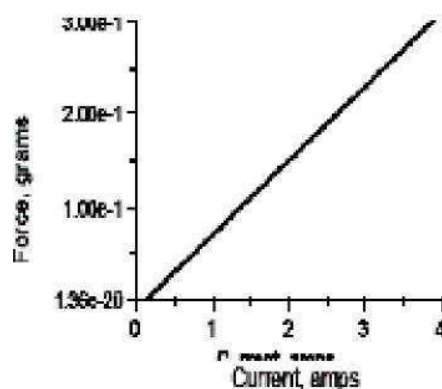

Figure 8.3: Sample plot of Current vs Force

current (amps)	Mass (gram)	Force (gram)	current (amps)	Mass (gram)	Force (gram)
0.0			3.0		
0.5			3.5		
1.0			4.0		
1.5			4.5		
2.0			5.0		
2.5					

Table 8.1: Table for taking data of magnetic force with current

ii. Part 2: Experiment of Force vs Length of current loop

- Determine the length of wire loop from the data sheet shown here.

Current loop	Length
SF 40	1.2 cm
SF 37	2.2 cm
SF 39	3.2 cm

Physics Laboratory Manual

SF 38	4.2 cm
SF 41	6.4 cm
SF 42	8.4 cm

Table 8.2: Length of different current loops

2. With no current flowing, determine the mass of the Magnet Assembly. Record this value on the line at the top of Table.
3. Set the current to 2.0 A. Determine the new “mass” of the Magnet Assembly. Record this value under “Mass” in Table 8.3.
4. Subtract the mass that you measured with no current flowing from the mass that you measured with the current flowing. Record this difference as the “Force.”
5. Turn the current off. Remove the Current Loop and replace it with another. Repeat steps 1-4.
6. Plot a graph of Force (vertical axis) versus Length (horizontal axis).
7. What is the nature of the relationship between these two variables? What does this tell us about how changes in the length of a current-carrying wire will affect the force that it feels when it is in a magnetic field?

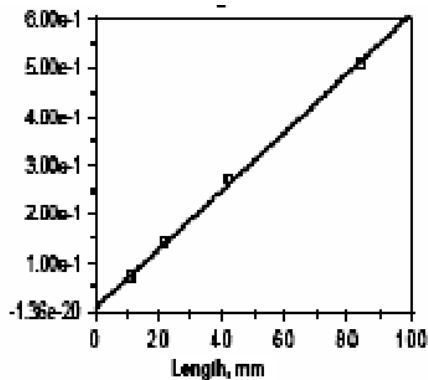

Figure 8.4: Sample plot of variation of magnetic force with length of current loop.

Mass with $I = 0 = \dots\dots\dots$ gm

Length (mm)	Mass (gram)	Force (gram)	Length (mm)	Mass (gram)	Force (gram)

--	--	--	--	--	--

Table 8.3: Table for taking data of magnetic force with length of current loop.

EXPERIMENT NO. 11

Aim of the Experiment: To study the induced emf as a function of velocity of a magnet passing through a coil and hence verify Faraday's law.

Apparatus: The set up consists of the following

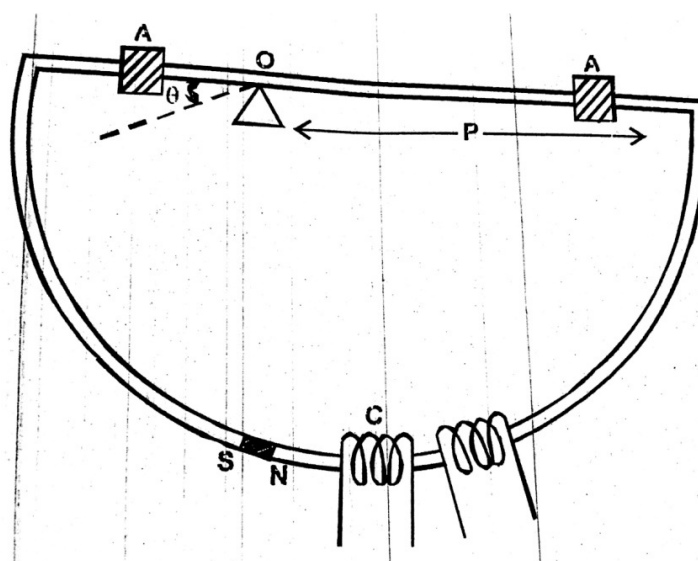

Figure 1

1. Mechanical part consisting of a permanent magnet mounted on an arc of a semi-circle of radius 40 cm. The arc is part of a rigid frame of aluminium and is suspended at the centre of arc so that the whole frame can oscillate freely in its plane (Fig. 1). Weights A, A' have been provided on the diagonal arm, so that by altering their position time period T can be varied from 1.5 to 3 sec. Two coils of about 10,000 turns of copper wire loop the arc, so that the magnet can pass freely through the coil. The two coils are independent and can be connected in series or parallel. The amplitude of the swing can be read from the graduated circle by the pointer.
2. Measurement board has a voltmeter with four ranges; 0-2.5 V, 5 V, 10 V, and 20 V, and an ammeter with two ranges 1mA, 2.5 mA. The board also has four

different value of condensers, five resistances, two diodes and one SPST switch for performing experiments.

Introduction: The basic principle of generation of alternating emf is electromagnetic induction discovered by Michael Faraday. This phenomenon is the production of an induced emf in a circuit caused by a change of the magnetic flux linking the circuit. Faraday's laws of induction tells us that the induced emf is given by

$$= \frac{d\phi}{dt} \quad (1)$$

Here $\frac{d\phi}{dt}$ represents the rate of change of flux linking the circuit. In SI units, ϵ will be in Volts.

Theory: For studying the induced emf as a function of velocity of the magnet passing through the coil, the magnet NS, which is kept at the middle of the aluminium arc, is allowed to swing from one side to the other and it passes through the coil on the way. The aluminium frame swings about the pivot O. The period is adjustable by sliding the loads A, A'. If D is released from angle θ_0 from the equilibrium, the velocity V_{max} with which the magnet passes the coil is given by

$$= \sqrt{2gR(1 - \cos\theta_0)} \quad (2)$$

where R is radius of the D-shape arc.

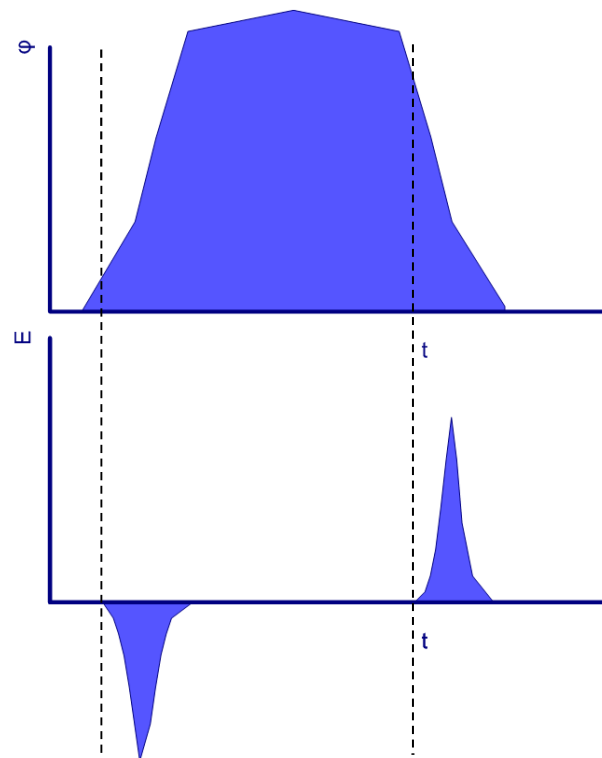

Figure 2

The magnetic flux through the coil ϕ changes as the magnet NS passes through it as shown in Fig 2. Two pulses of opposite signs are generated in the coil for each swing and the peak ϵ_0 corresponds to maximum $\frac{d\phi}{dt}$.

Procedure:

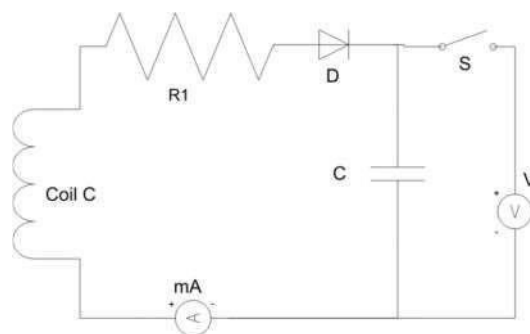

Figure 3

1. Make the circuit as shown in Fig. 3. Keep switch S in OFF position (Here R_1 represents the internal resistance of the coil and the forward resistance of the diode D). $C = 100 \mu\text{F}$ and $R_1 \approx 500 \Omega$. At each swing the diode permits the capacitor to gain charge only for one of the pulses. The charging time RC being 50 ms and the pulse width τ being a little smaller, the capacitor reaches the E_0 value in a few swings.
2. When the milliammeter shows no more kicks, it means the capacitor C has reached the potential E_0 . Measure this potential by changing the switch to ON position and take reading on voltmeter.
3. Vary V_{max} by choosing different θ_0 values and measure E_0 each time.
4. Plot a graph of E_0 versus V_{max} and observe it is linear.
5. Repeat after shifting loads **A**, **A'**, so that T changes. The E_0 versus V_{max} data in this set-up fall on the same graph line as in step 4. Fig. 4 shows a graph of ideal results of an experiment.

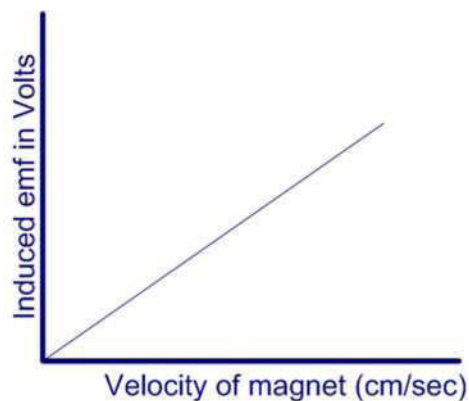

Figure 4

Observations: Make an observation table as given below for each time period. Make similar observation tables for two more time periods T_2 and T_3 .

$$R = \underline{\hspace{2cm}}.$$

1. Table 1: For time period $T_1 = \underline{\hspace{2cm}}$, $\theta_0 = \underline{\hspace{2cm}}$. Use eqn 2 to find V_{max} .

Sl. No	θ_0 (Amplitude in degrees)	V_{max} (Maximum velocity of magnet)	E_0 (Measured induced emf)
1	5		

Physics Laboratory Manual

2	10		
3	15		
4	20		
5	25		

EXPERIMENT NO. 12

Aim of the Experiment: To determine the wavelength of prominent spectral lines of mercury light by a plane transmission grating using normal incidence.

Apparatus Required: A spectrometer, Mercury lamp, Transmission grating, Reading lamp and Reading lens.

Theory: In some of the optics experiments, we will use a spectrometer. The spectrometer is an instrument for studying the optical spectra. Light coming from a source is usually dispersed into its various constituent wavelengths by a dispersive element (prism or grating) and then the resulting spectrum is studied. A schematic diagram of prism spectrometer is shown in Fig.1. It consists of a collimator, a telescope, a circular prism table and a graduated circular scale along with two verniers. The collimator holds an aperture at one end that limits the light coming from the source to a narrow rectangular slit. A lens at the other end focuses the image of the slit onto the face of the prism. The telescope magnifies the light dispersed by the prism (the dispersive element for your experiments) and focuses it onto the eyepiece. The angle between the collimator and telescope are read off by the circular scale. The detail description of each part of the spectrometer is given below.

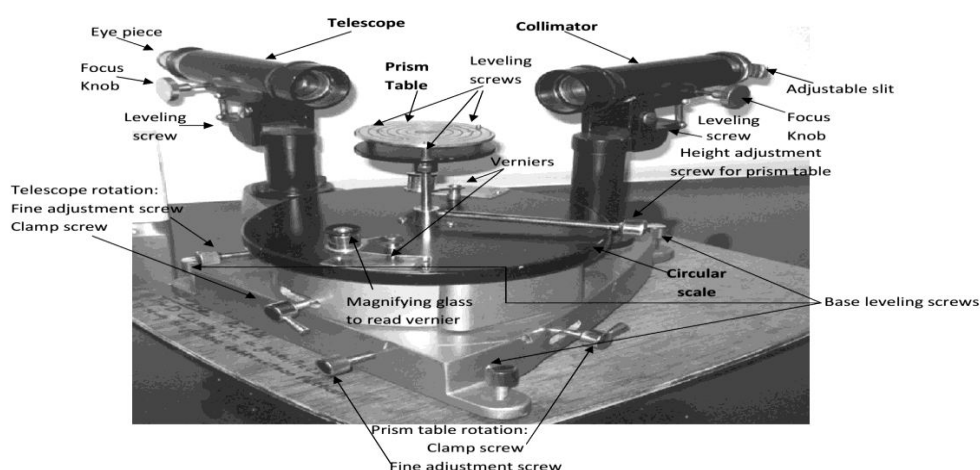

Figure-1: Different parts of spectrometer

Physics Laboratory Manual

- a) **Collimator (C):** It consists of a horizontal tube with a converging achromatic lens at one end of the tube and a vertical slit of adjustable width at the other end. The slit can be moved in or out of the tube by a rack and pinion arrangement using the focus knob and its width can be adjusted by turning the screw attached to it. The collimator is rigidly fixed to the main part of the instrument and can be made exactly horizontal by adjusting the leveling screw provided below it. When properly focused, the slit lies in the focal plane of the lens. Thus the collimator provides a parallel beam of light.
- b) **Prism table (P):** It is a small circular table and capable of rotation about a vertical axis. It is provided with three leveling screws. On the surface of the prism table, a set of parallel, equidistant lines parallel to the line joining two of the leveling screws, is ruled. Also, a series of concentric circles with the centre of the table as their common centre is ruled on the surface. A screw attached to the axis of the prism table fixes it with the two verniers and also keep it at a desired height. These two verniers rotate with the table over a circular scale graduated in fraction of a degree. The angle of rotation of the prism table can be recorded by these two verniers. A clamp and a fine adjustment screw are provided for the rotation of the prism table. It should be noted that a fine adjustment screw functions only after the corresponding fixing screw is tightened.
- c) **Telescope (T):** It is a small astronomical telescope with an achromatic doublet as the objective and the Ramsden type eye-piece. The eye-piece is fitted with cross-wires and slides in a tube which carries the cross-wires. The tube carrying the cross wires in turn, slides in another tube which carries the objective. The distance between the objective and the cross-wires can be adjusted by a rack and pinion arrangement using the focus knob. The Telescope can be made exactly horizontal by the leveling screws. It can be rotated about the vertical axis of the instrument and may be fixed at a given position by means of the clamp screw and slow motion can be imparted to the telescope by the fine adjustment screw.

d) Circular Scale (C.S.): It is graduated in degrees and coaxial with the axis of rotation of the prism table and the telescope. The circular scale is rigidly attached to the telescope and turned with it. A separated circular plate mounted coaxially with the circular scale carries two verniers, V1 and V2, 180° apart. When the prism table is clamped to the spindle of this circular plate, the prism table and the verniers turn together. The whole instrument is supported on a base provided with three leveling screws. One of these is situated below the collimator.

1. Measurement of angles with the help of spectrometer:

The spectrometer scales are angle measuring utilities for the positions of the telescope which can be rotated about the central axis of the instrument. The main circular scale is attached with the telescope so that when the telescope is rotated, the main circular scale also rotates with it. The angle, through which the telescope is rotated, can be measured by reading the positions of the verniers attached to the prism table and sliding over the main scale. In a spectrometer there are two sets of main circular scales (fitted with the telescope) and vernier scale (attached with the prism table). Both sets are diagonally (left hand and right hand sides) fixed in the instrument and measures angle for a particular telescope position with a difference of 180 degrees. These scales can be used in a similar manner as a simple Vernier Caliper or traveling microscope is used. The vernier Caliper or traveling microscope is used to measure small distances (in centimeters and fractions whereas spectrometer scales are used to measure small angular displacements (in degrees, minutes, and seconds){1 degree is equal to 60 minutes, and 1 minute is equal to 60 seconds; ($1^\circ = 60'$ and $1' = 60''$)

2. Least Count of the Spectrometer Scale:

BIT, Physics Laboratory has two types of spectrometers in which

- (i) 60 divisions of vernier Scale are equal to 59 divisions of the Main Scale, and
- (ii) 30 divisions of vernier Scale are equal to 29 divisions of the Main scale.

Now, we will find out the least count in first case which 60 divisions of Vernier scale are equal to 59 divisions of the main scale. The method is as follows:

- a) Value of one division of circular main scale = $0.5^\circ = 30'$ (as $1^\circ = 60'$)
- b) Value of one division of sliding vernier scale = $(59/60) \times 0.5^\circ$

Physics Laboratory Manual

- c) Least count of spectrometer scale = Value of 1 div. of main scale – value of 1 div. of vernier = $0.5^\circ - [(59/60) \times 0.5]^\circ$
 $= [0.5 \times 1/60]^\circ = 0.5' = 30''$ (THIRTY SECONDS)
- d) Similarly the least count of the spectrometer scale in second case in which 30 divisions of Vernier scale are equal to 29 divisions of the circular main scale can also be calculated. In this case the value of least count will be 1' or 60''.

3. Taking Readings on the two Spectrometer scales:

Following is an illustration for taking observation reading using the left hand side set of the circular main scale (attached with the telescope) and the corresponding vernier scale (sliding over the circular main scale and attached with the prism table). Assuming that we are using the spectrometer in which 60 divisions of vernier scale are equal to 59 divisions of the main scale.

The 0th division of the vernier scale precedes the circular main scale division whose value is 234° and $30'$. Therefore the main scale division reading is $234^\circ 30'$. Let 13th division of vernier scale coincides completely with a main scale division. Therefore the vernier scale reading would be =13x
Least count of vernier scale

$$=13 \times 30'' = 390'' = 6' 30''$$

$$\begin{aligned} \text{Total Spectrometer Scale Reading} &= \text{Circular Main scale Reading} + \text{Vernier Reading} \\ &= 234^\circ 36' 30'' \end{aligned}$$

Reading of the right hand side scale can be similarly observed. The readings taken from left hand side and right hand side should ideally differ by 180°

4. Formula Used: The wavelength λ of any spectral line using plane transmission grating can be calculated from the formula $(e+d) \sin\theta = n \lambda$, Where $(e+d)$ is the grating element, θ is the angle of diffraction, and n is the order of the spectrum. If there are N lines per inch ruled on the grating surface then the grating element is given by $(e+d) = 2.54/N$ cm. Hence $(2.54/N) \sin\theta = n\lambda$, or $\lambda = 2.54 \sin\theta / nN$ cm.

5. Procedure

1) Adjustment of the grating for normal incidence:

The initial adjustment of the spectrometer is made as usual. The plane transmission grating is mounted on the prism table. The telescope is released and placed in front of the collimator. The direct reading is taken after making the vertical cross-wire to coincide with the fixed edge of the image of the slit, which is illuminated, by a monochromatic source of light. The telescope is then rotated by an angle 90° (either left or right side) and fixed. The grating table is rotated until on seeing through the telescope the reflected image of the slit coincides with the vertical cross-wire. This is possible only when the reflected image of the slit coincides with the vertical cross-wire. This is possible only when a light emerging out from the collimator is incident at an angle 45° to the normal to the grating. The vernier table is now released and rotated by an angle 45° towards the collimator. Now light coming out from the collimator will be incident normally on the grating. (Fig 2).

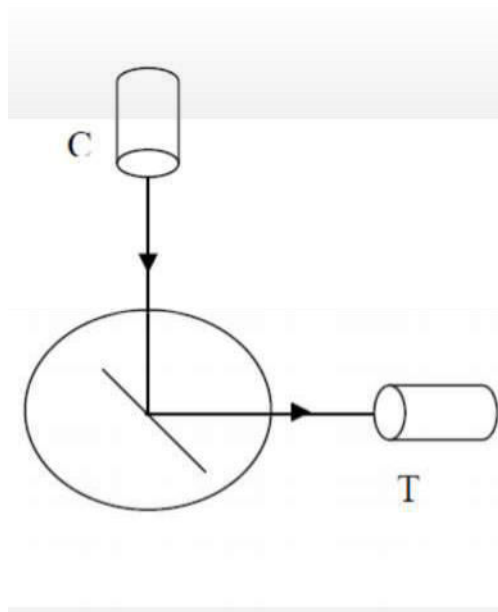

FIG.2

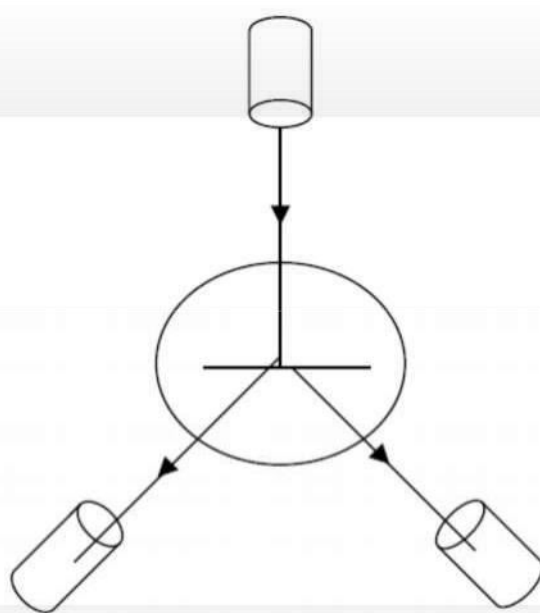

FIG.3

2) Standardization of the grating:

The slit is illuminated by sodium light. The telescope is released to catch the different image of the first order on the left side of the central direct image. The readings in the two vernier are noted. It is

then rotated to the right side to catch the different image of the first order, the readings are noted. (Fig.3). The difference between the positions of the right and left sides given twice the angle of diffraction $2\theta^\circ$. The number of lines per meter of the grating (N) is calculated by using the given formula assuming the wavelength of the sodium light as 589.3 nm.

3) Wavelengths of the spectral lines of the mercury spectrum:

The sodium light is removed and the slit is now illuminated by white light from mercury vapour lamp. The telescope is moved to either side of the central direct image, the diffraction pattern of the spectrum of the first order and second order are seen. The readings are taken by coinciding the prominent lines namely violet, blue, bluish – green, yellow1, yellow2 and red with the vertical wire. The readings are tabulated and from this, the angles of diffraction for different colours are determined. The values are tabulated in table. The wavelengths for different lines are calculated by using the given formula.

6. Observations:

A. For the adjustment of grating for normal incidence:

1. Least count of the Spectrometer scale:

Value of 1 division of main scale =

Divisions of main scale are equal to divisions of vernier scale.

Value of 1 division of vernier scale.

Least count of Spectrometer scale:

= value of 1 division of main scale – 1 division of vernier scale.

2. Reading of the telescope for direct image of the slit:

V1 = V2 =

3. Reading of the telescope after rotating it through 90° :

V1 = V2 =

4. Reading of prism table when reflected image of the slit coincides with the vertical cross wire V1 = V2 =

1. Reading of prism table when rotated through 45° or 135° :

Physics Laboratory Manual

V1 = V2 =

1. Number of lines N ruled per inch on the grating
2. Grating element $(e+d) = 2.54/N$

B. Calculations:

For first order, $n=1$, $\lambda = (e+d) \sin\theta/2$ cm.

λ for Violet I colour =cm.

Calculate λ for all visible spectral lines also.

The mean value of λ for Violet I colour = cm.

(Calculate the mean value of λ for other visible spectral lines also.)

C. Results

Table 3.1: Table for the measurement of the angle of diffraction θ

Order	Color of the spectral line	Spectrum to the left of the direct images			Spectrum to the right of the direct images			$2\theta=X-Y$	Angle= θ
		M.S.R	V.S.R	T.R=(X)	M.S.R	V.S.R	T.R=(Y)		
1 st Order	Violet Window 1 Window 2								
	Blue Window 1 Window 2								
	Green Window 1 Window 2								
	Yellow Window 1 Window 2								
	Red Window 1 Window 2								
2 nd Order	Violet Window 1 Window 2								
	Blue								

Physics Laboratory Manual

	Window 1 Window 2								
	Green Window 1 Window 2								
	Yellow Window 1 Window 2								
	Red Window 1 Window 2								

Table 3.2: Observations for grating element ($e+d$)

Colour of the Spectral line	Wavelength as obtained by experiment	Standard value of wavelength	Percentage error %
Violet I		4047 Å	
Blue		4358 Å	
Green		5461 Å	
Yellow I		5770 Å	
Red		6234 Å	

7. Source of Error and Precautions

1. The axes of the telescope and the collimator must intersect at and be perpendicular to the main axis of the spectrometer.
2. The collimator must be so adjusted as to give out parallel rays.
3. The telescope must be so adjusted as to receive parallel rays and form a well defined image of the slit on the crosswire.
4. The prism table must be optically leveled.
5. The grating should be so mounted on the prism table that its ruled lines are parallel to the main axis of the spectrometer.
6. The plane of the grating should be normal to the incident light and its ruled surface must face the telescope so that the error due to nonparallelism of the incident rays is minimum.
7. The slit should be as narrow as possible and parallel to the ruled surface of the grating.

8. While handling the grating one should not touch its faces but hold it between the thumb and the fingers by edges only.
9. While taking observations of the spectral lines, the prism table must remain clamped.
10. The reading of both the verniers should be recorded. This eliminates the error due to non-coincidence of the center of the graduated scale with the main axis of the spectrometer.

8. Sample Questions:

- What do you understand by diffraction of light?
- How does it differ from interference of light?
- What is a diffraction grating?
- How do you measure the wavelength of light using grating?
- What is grating element?
- How do you adjust telescope and collimator for parallel rays?
- How do you set the grating for normal incidence?
- Why the ruled surface of grating face should forwards the telescope?
- How many orders of spectra are you getting with the grating?
- What is the difference between a prism spectrum and a grating spectrum?
- What are the various series of lines observed in hydrogen spectrum?
- What is Rydberg constant?
- A transmission grating with 2000 lines/cm is illuminated by a beam of 694.3-nm light from a laser. Spots of light, on both sides of the undeflected beam, appear on a screen 2.0 m away.
 - 1) How far from the central axis is either of the two nearest spots?
 - 2) Find how much difference it makes whether you use the approximation $\sin \theta \approx \theta$