



Module I: Bonding in Coordination Complex

Introduction to Chemical Bonding, Werner's Theory, Bonding in coordination complexes, Crystal Field Theory, Octahedral, Tetrahedral and Square planar complexes, CFSE, Jahn Teller theorem, Spectral, electronic and magnetic properties of coordination complexes.

I. Solved Questions with Model Answers/Hints:

1. Differentiate between a double salt and a coordination compound.

Ans. (i) A double salt is an addition compound that completely dissociates in solutions, leading to 100% ionization. Eg. Mohr salt $[\text{FeSO}_4(\text{NH}_4)_2\text{SO}_4 \cdot 6\text{H}_2\text{O}]$

A coordination compound does not lead to 100% ionization, Eg. $[\text{Cu}(\text{NH}_3)_4]\text{SO}_4$, it has at least one complex ion.

(ii) Properties of individual ions are retained in double salts and not in coordination compounds

(iii) Metal ions in double salts have normal valency, whereas in coordination complexes, they have two types of valencies (primary and secondary).

2. What are ligands? How are they classified?

Ans: Chemical species that share electrons with the central atom are called ligands. They are classified as:

(A) On the basis of charge: Neutral (NH_3 , NS , NO , H_2O); Anionic (F^- , CH_3COO^- , Cl^-); Cationic ($\text{H}_2\text{N}-\text{NH}_2$, NO^+)

(B) Denticity: Monodentate (NH_3), Polydentate (EDTA)

(C) Chelation: Chelating $[\text{Fe}(\text{edta})]^-$ & Non chelating ligands (H_2O)

(D) Interaction with metal: (i) Ligand to Metal bonding $\text{M} \leftarrow \text{L}$ bonding (NH_3),

(ii) Metal to Ligand bonding $\text{M} \leftrightarrow \text{L}$ bonding (CO , NO)

called as synergic bonds

3. What are ambidentate ligands?

Ans. Ligands have different donor sites that can be coordinated to metal atom at a time. E.g., a Thiocyanate ion (NCS) can either attach to a metal atom through the -N atom to give a thiocyanate-N complex or by an S atom to give a thiocyanate-S complex. Other eg.s are NO_2^- , CN^- , $\text{S}_2\text{O}_3^{2-}$

4. Nomenclature of the following complex ions:

(i) $[\text{Co}(\text{NH}_3)_6]\text{Cl}_3$: hexaamminecobalt (III) chloride

(ii) $\text{K}[\text{PtCl}_5(\text{NH}_3)]$: potassium amminepentachloridoplatinate (IV)

(iii) $\text{Ca}_2[\text{Fe}(\text{CN})_6]$: calcium hexacyanoferrate (II)

(iv) $[\text{Co}(\text{SCN})_4]^{2-}$: tetrathiocyanatocobaltate(II) ion.

(v) $\text{K}_3[\text{Fe}(\text{CN})_6]$: Potassium hexacyanoferrate (III)

(vi) $[\text{Fe}(\text{CO})_5]$: Pentacarbonyliron (0)

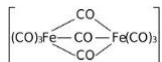

- (vii) $[\text{Co}(\text{NO}_2)_3(\text{NH}_3)_3]$: triamminetrinitrito-N-cobalt(III)
(viii) $[\text{Co}(\text{ONO})(\text{NH}_3)_5]\text{SO}_4$: pentaamminenitrito-O-cobalt(III) sulphate
(ix) $[\text{Fe}(\text{C}_5\text{H}_5)_2]$: Bis(cyclopentadienyl)iron(II)
(x) $[\text{CuCl}_2(\text{CH}_3\text{NH}_2)_2]$: Dichlorobis(methylamine)copper(II)
(xi) $[(\text{NH}_3)_5\text{Co}-\text{NH}_2-\text{Co}(\text{NH}_3)_5] (\text{NO}_3)_5$: μ -amidobis[pentaamminecobalt(III)] nitrate
(xii)  Tri- μ -carbonylbis[tricarbonyliron(0)]

5. Calculate oxidation state of central metal atom and write its name as per IUPAC convention:

(i) $\text{CoCl}(\text{NH}_3)_5\text{Cl}_2$

In this case the ligands are chloro and ammine. The complex is cation and chloride is anion. The oxidation state of cobalt is III as

$x + 5(0) - 1 - 2 = 0$ or $x = +3$. Its name is pentaamminechloridocobalt(III) chloride

(ii) $\text{K}_3[\text{Fe}(\text{CN})_6]$

In this case, the ligands are cyano. The complex is anionic. The oxidation state of iron is +3 as $3(+1) + x + 6(-1) = 0$ The name of the complex is potassium hexacyanoferrate(III).

(iii) $[\text{Co}(\text{H}_2\text{NCH}_2\text{CH}_2\text{NH}_2)_3] (\text{SO}_4)_3$

In this case, ligands are ethane-1, 2-diamine (or ethylenediamine). The complex is cationic. The oxidation state of cobalt is +3 as

$[x + 3 \times 0]2 + 3(-2) = 0$ or $2x = +6$ or $x = +3$

The name of the complex is tris (ethane-1, 2-diamine) cobalt(II) sulphate.

(iv) $[\text{Ag}(\text{NH}_3)_2] [\text{Ag}(\text{CN})_2]$

Both cation and anion are complexes. The oxidation state of silver in both cationic and anionic complexes is +1. The name of the complex is diamminesilver (I) dicyanoargentate (I)

6. What are the main postulates and significance of Werner's theory?

Ans: Main Postulates:

- (i) A complex compound can be represented as an inner coordination and outer ionization sphere. The ionization sphere satisfies the primary valencies of metal and the coordination sphere satisfies the secondary valencies of metal.

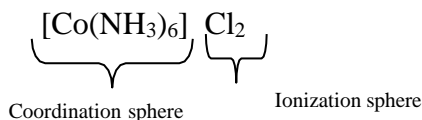



- (ii) Every metal has fixed number of secondary valencies, which equals the no. of ligands coordinated to the metal. Primary valency equals the charge on the complex ion.
- (iii) Primary valencies or ionizable links are satisfied by the negative ions and equal the oxidation state of the metal while secondary valencies may be satisfied by either neutral molecules or negative ions which equal the coordination no. of the metal.
- (iv) Primary valencies are non-directional while secondary are directional with some definite spatial arrangement.

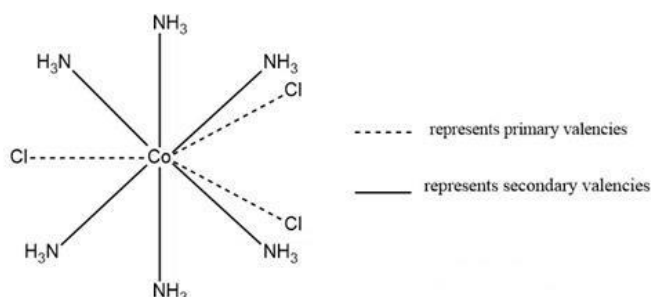

Werner's representation of complex $[\text{Co}(\text{NH}_3)_6]\text{Cl}_3$

Significance: It helps to understand the structure, formation and nature of complexes which can be applied to understand their different properties.

7. Differentiate between inner orbital and outer orbital complexes?

Ans. (i) **Inner orbital complex:** If the complex is formed using inner d-orbitals for hybridisation (written as d^2sp^3), it is called inner orbital complex. In the formation of inner orbital complex, the electrons of the metal are forced to pair up and hence the complex will be either diamagnetic or will have lesser number of unpaired electrons. Such a complex is also called low spin complex. Eg., $[\text{Fe}(\text{CN})_6]^{3-}$ and $[\text{Co}(\text{NH}_3)_6]^{3+}$ are inner orbital complexes.

Inner orbital complex (uses inner (n-1) d orbitals) = low spin complex

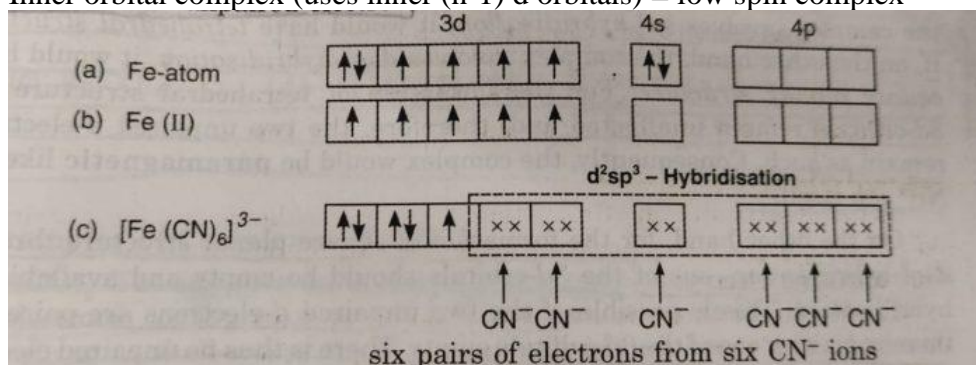

(ii) **Outer orbital complex:** If the complex is formed using outer d-orbitals for hybridisation, it is called an outer orbital complex. The outer orbital complex will have larger number of unpaired electrons since the configuration of the metal ion remains undisturbed. Such a complex is also called high spin complex. Eg., $[\text{Fe}(\text{H}_2\text{O})_6]^{3+}$ and



$[\text{CoF}_6]^{3-}$ are outer orbital complexes.

Outer orbital complex (uses outer nd orbitals) = high spin complex

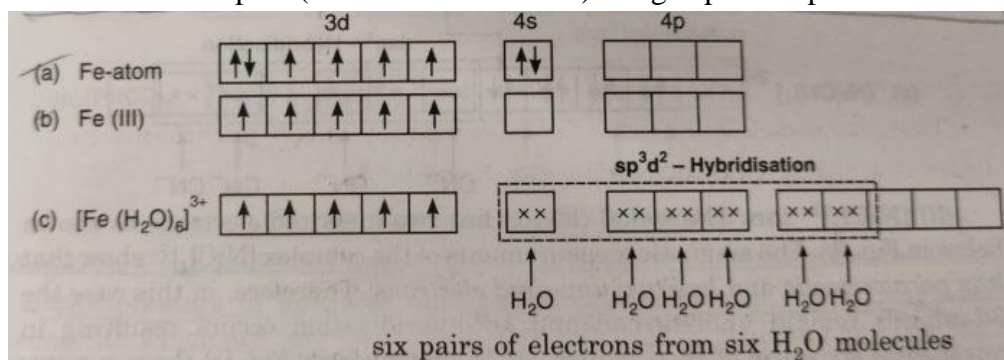

8. Explain bonding in $[\text{Cr}(\text{NH}_3)_6]^{3+}$ complex using Valence bond theory?

Ans. Chromium ($Z = 24$) has the electronic configuration $3d^5 4s^1$. The chromium in this complex is in +3 oxidation state and the ion is formed by the loss of one 4s and two of the 3d-electrons. The inner d-orbitals are already vacant and two vacant 3d, one 4s and three 4p-orbitals are hybridised to form six d^2sp^3 hybrid orbitals. Six pairs of electrons one from each NH_3 molecule (shown by xx) occupy the six vacant hybrid orbitals. The molecule has octahedral geometry. Since the complex contains three unpaired electrons, it is paramagnetic.

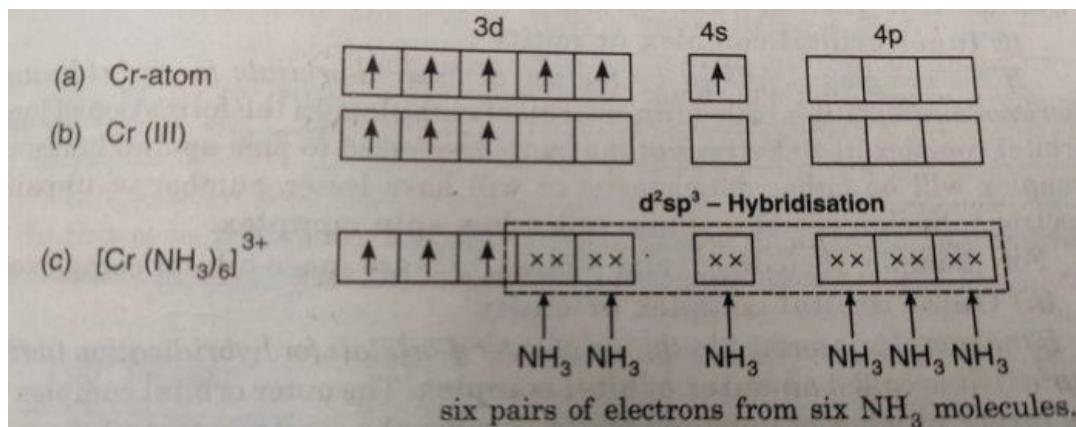

9. Explain bonding in $[\text{CoF}_6]^{3-}$ complex using Valence bond theory?

Ans. Cobalt is in +3 oxidation state and has the electronic configuration $3d^6$. This complex has been found to be paramagnetic due to the presence of four unpaired electrons. The electrons in 3d-orbitals are not disturbed and the outer 4d-orbitals are used for hybridisation. The six orbitals (one 4s, three 4p and two 4d) are hybridised forming six sp^3d^2 hybrid orbitals. Six pairs of electrons, each one from F ion are donated to the vacant hybrid orbitals forming Co-F bonds.

Thus, the complex has octahedral geometry and is paramagnetic.

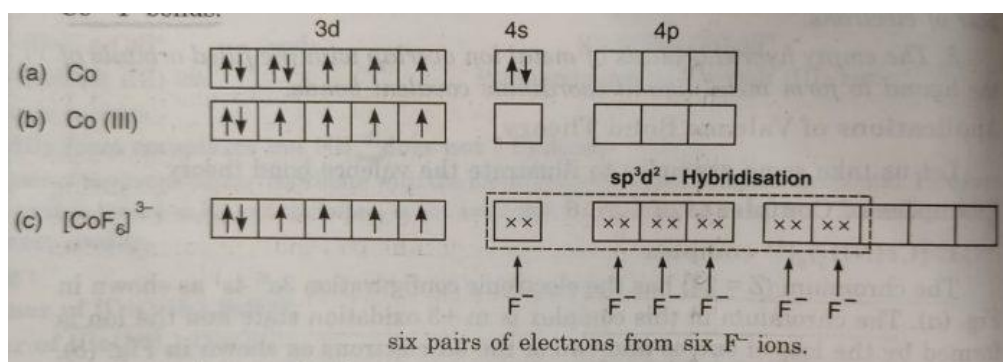

10. Explain bonding in $\text{Fe}(\text{CO})_5$ complex using Valence bond theory?

Ans. The oxidation state of iron in this complex is zero and it has the outer electronic configuration as $3d^6 4s^2$. According to the Hund's rule, the six electrons shall occupy the five 3d orbitals in such a way that there are four unpaired electrons. For the complexes with coordination number 5, the central atom may involve dsp^3 hybridisation, and the 4s orbital must be empty. The two electrons of 4s orbital and one electron 3d orbital are pushed into 3d orbitals to pair up with the three unpaired 3d electrons. The metal atom involves dsp^3 hybridisation (one 3d, one 4s and three 4p) to give vacant dsp^3 hybrid orbitals.

Since the complex has no unpaired electron, it will be diamagnetic and it is in agreement with experimental results. Thus, the complex $[\text{Fe}(\text{CO})_5]$ has trigonal bipyramidal geometry and is diamagnetic.

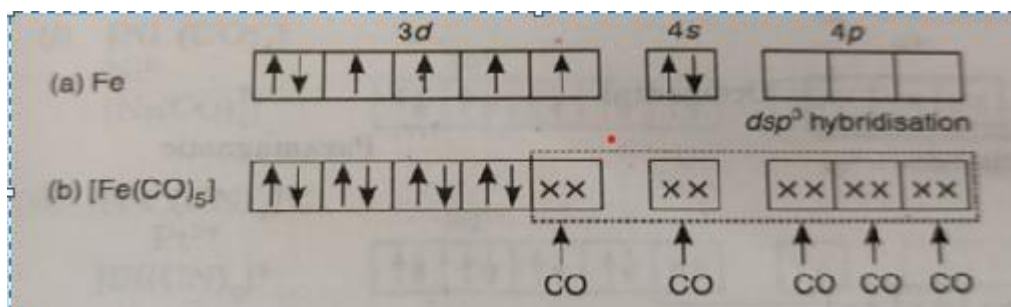

11. For the complex ion $[\text{Fe}(\text{Cl})_6]^{3-}$ determine the number of d electrons for Fe, sketch the d-orbital energy levels and the distribution of d electrons among them, list the number of lone electrons, and label whether the complex is paramagnetic or diamagnetic.

Ans. The oxidation state of Fe is Fe^{3+} . Based on its electron configuration, Fe^{3+} has 5 d-electrons. It has an octahedral geometry which means the energy splitting is:

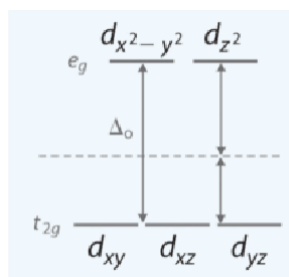

The ligand induces a strong or weak field spin. Cl^- is a weak field ligand (i.e., it induces high spin complexes). Therefore, electrons fill all orbitals before being paired. Five unpaired electrons suggest that it is strongly paramagnetic

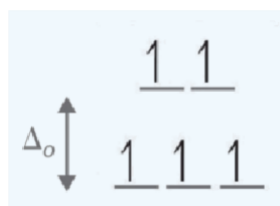

12. A *tetrahedral* complex absorbs at 545 nm. What is the respective octahedral crystal field splitting (Δ_o)?

$$\text{Ans. } \Delta t = hc/\lambda = (6.626 \times 10^{-34} \text{ Js})(3 \times 10^8 \text{ m/s}) / 545 \times 10^{-9} \text{ m} = 3.65 \times 10^{-19} \text{ J}$$

However, the *tetrahedral* splitting (Δt) is $\sim 4/9$ that of the *octahedral* splitting (Δ_o).

$$\Delta t = 0.44 \Delta_o = \Delta_o = \Delta t / 0.44$$

$$= 3.65 \times 10^{-19} \text{ J} / 0.44 = 8.30 \times 10^{-18} \text{ J}$$



This is the energy needed to promote *one* electron in *one* complex. Often the crystal field splitting is given per mole, which requires this number to be multiplied by Avogadro's Number (6.022×10^{23}).

13. Calculate the total pairing energy for $[\text{Cr}(\text{H}_2\text{O})_6]^{2+}$ ion in high and low spin state. The mean pairing energy is 23500 cm^{-1} .

Ans. In $[\text{Cr}(\text{H}_2\text{O})_6]^{2+}$ ion, Cr is present as Cr^{2+} which is a d^4 ion. Thus, the configuration of d^4 ion in high spin state is $t_{2g}^3 e_g^1$ which gives $m=0$ and hence:

Total pairing energy of $[\text{Cr}(\text{H}_2\text{O})_6]^{2+}$ ion in high spin state = $0 \times P = 0$

The configuration of d^4 ion in high spin state is $t_{2g}^4 e_g^0$ which gives $m=1$ and hence:

Total pairing energy of $[\text{Cr}(\text{H}_2\text{O})_6]^{2+}$ ion in low spin state = $1 \times P = 1 \times 23500 \text{ cm}^{-1} = 23500 \text{ cm}^{-1}$

14. Calculate crystal field stabilization energy (CFSE) for the following complexes:

(a) $[\text{Co}(\text{CN})_6]^{3-}$ (b) $[\text{Fe}(\text{CN})_6]^{3-}$ (c) $[\text{CoCl}_6]^{4-}$

Ans.

(a) $[\text{Co}(\text{CN})_6]^{3-}$ Co^{3+} , d^6 , CN^- strong ligand;

low spin CFSE = $-2.4\Delta_o + 2P$

(b) $[\text{Fe}(\text{CN})_6]^{3-}$ Fe^{3+} , d^5 low spin CFSE = $-2.0\Delta_o + 2P$

(c) $[\text{CoCl}_6]^{4-}$ Co^{2+} , d^7 , Cl^- weak ligand high spin CFSE = $-0.8\Delta_o$

15. Magnetic moments of some complexes are as follows. Predict on the basis of this data whether they are high spin or low spin complexes

(a) $\text{K}_3[\text{Mn}(\text{NO}_2)_6]$ 2.87 BM

(b) $[\text{Co}(\text{NH}_3)_6]\text{Cl}_2$ 1.73 BM

(c) $\text{K}_4[\text{Fe}(\text{CN})_6]$ 0 BM

Ans. $\text{K}_3[\text{Mn}(\text{NO}_2)_6]$ 2.87 BM = 2 Unpaired electrons, Mn^{3+} , d^4 low spin

$[\text{Co}(\text{NH}_3)_6]\text{Cl}_2$ 1.73 BM = 1 Unpaired electron, Co^{2+} , d^7 low spin

$\text{K}_4[\text{Fe}(\text{CN})_6]$ 0 BM = 0 Unpaired electron, Fe^{2+} , d^6 low spin

16. Draw the crystal field splitting diagram of d orbitals in a linear complex MX_2 , assuming the ligands (X) to be along the z axis.

Ans. Electron-electron repulsion between M and X will be there only for d orbitals having an z component. Out of these maximum repulsion will be for d_z^2 since lobes are along the z axis. Next will be d_{xz} and d_{yz} having lobes in between z and another axis and both will be degenerate. The other two orbitals have no z component and will be stabilized to maintain barycentre.

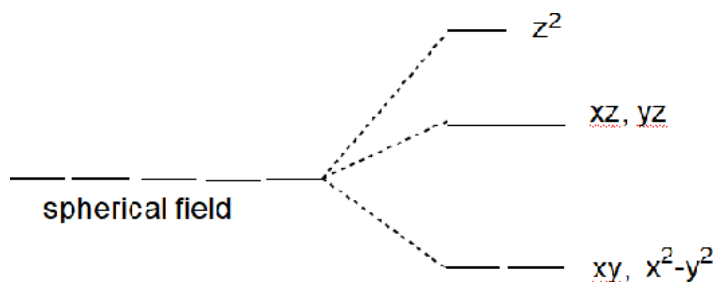

17. $[\text{Co}(\text{NH}_3)_6]^{3+}$ is diamagnetic and orange yellow. $[\text{CoF}_6]^{3-}$ on the other hand is paramagnetic and blue. Why ?

color wheel to determine approx. complementary colors

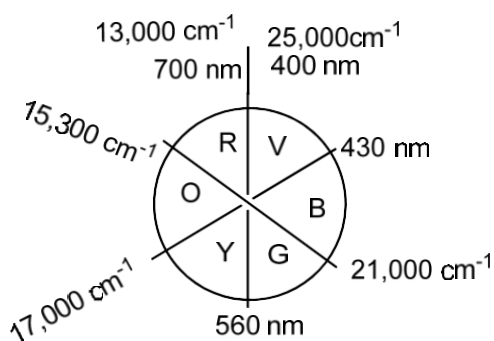

Ans. $[\text{Co}(\text{NH}_3)_6]^{3+}$: T_{2g}^6 diamagnetic = no unpaired electrons

Orange yellow means absorption in the Violet-blue region (higher frequency, larger Δ_o) d^6 LS

$[\text{CoF}_6]^{3-}$ paramagnetic $t_{2g}^4 e_g^2$

Blue means absorption in the orange region (lower frequency, smaller Δ_o) therefore d^6 HS

18. $K_3[Co(CN)_6]$ is colorless while $K_3[Co(C_2O_4)]$ is colored. Why ?

Ans. $K_3[Co(CN)_6]$ $Co^{3+} d^6 LS t_{2g}^6 e_g^0$; $K_3[Co(C_2O_4)]$ $Co^{3+} d^6 HS t_{2g}^4 e_g^2$

d-d transitions are spin allowed in both cases. However CN^- being a very strong ligand the magnitude of Δ_o will be high and absorption can occur in the UV region for the cyano complex. Therefore it is colorless.

19. Explain the nature of Jahn-Teller distortion expected for an octahedral complex of $Cu(II)$ ion.

Ans. If the ground electronic configuration of a non-linear complex is orbitally degenerate, the complex will distort so as to remove the degeneracy and achieve a lower energy. This is called the Jahn-Teller Effect.

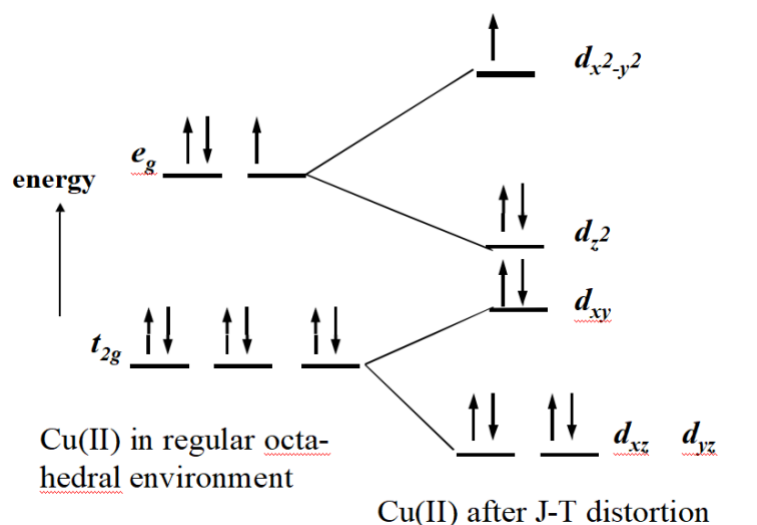

20. Explain the role of CFT in coloured complexes giving any two examples?

Ans.

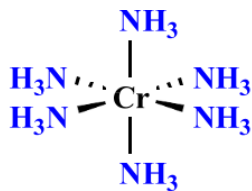

Strong ligands, leading to high Δ_o . Absorbs violet and appears yellow.

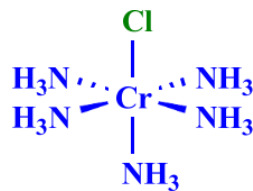

Relatively weak set of ligands, leading to reduced Δ_o . Absorbs yellow and appears magenta.

21. Is MnCr_2O_4 likely to have a normal or inverse spinel structure?

We need to consider whether there is a ligand-field stabilization. Because Cr^{3+} (d^3) has a large ligand-field stabilization energy ($1.2\Delta_o$) in the octahedral site (but a much smaller one in a tetrahedral field) whereas the high spin d^5 Mn^{2+} ion does not have any LFSE, a normal spinel structure is expected.

22. Explain the structure of dimeric Cu (II) acetate monohydrate?

Ans. Copper (II) acetate monohydrate exists as a dimer, and its structure is shown in Fig. The magnetic moment of the compound is only 1.43 BM, which is less than the spin-only value of 1.73 BM for one unpaired electron. The sub-normal magnetic moment value is due to the antiferromagnetic exchange of unpaired electrons of two CuII ions. In its structure, the acetate groups act as bidentate bridging groups between the two copper atoms. Therefore, each copper atom is surrounded by four oxygen atoms in a square planar arrangement. The oxygen atom from a water molecule occupies the fifth position around each Cu atom. The other copper atom occupies the sixth of the octahedral positions through the δ bond. Experimental evidence shows that electron exchange takes place through bridging carboxylate ligands.

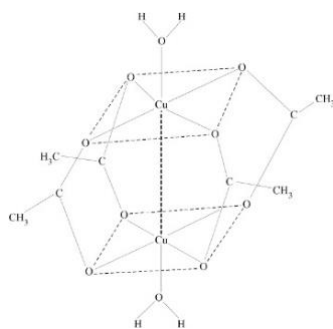

23. Why the complexes that contain metal ions of d^{10} electron configuration are usually colourless.

Ans. Complexes with d^{10} electron configuration like $[\text{Cu}(\text{PPh}_3)_4]^+$ and $[\text{Zn}(\text{H}_2\text{O})_6]^{2+}$ are usually colourless due to the absence of d-d transition. A metal complex with no d-electron is colorless as well.

However, a few of such complexes are strongly colored, for example, MnO_4^- or $[\text{Cr}_2\text{O}_7]^{2-}$. The origin of the color in these complexes is not the d-d transitions, but it is due to 'charge transfer' phenomenon.

24. What is Beer-Lambert's Law?

Ans. $A = \log_{10}(I_0/I) = \epsilon cl$

ϵ is the molar extinction coefficient (in $\text{L cm}^{-1} \text{mole}^{-1}$), c is concentration in mole L^{-1} and l is the path length in cm. A is known as 'Absorbance' and it is dimensionless.

25. What is 'Charge transfer' phenomenon in complexes?

Ans. Charge Transfer phenomenon is observed if the energies of empty and filled ligand- and metal-centered orbitals are similar. The direction of the electron transfer is determined by the relative energy levels of these orbitals:

i) Ligand to-Metal charge transfer (LMCT) like in MnO_4^- , CrO_4^{2-} etc. For MnO_4^- , the d-electron count on Mn(VII) is d^0 . The origin of the color in this species is not due to d-d transition, rather, charge transfer from O^{2-} to Mn(VII), described as LMCT band.

ii) Metal-to Ligand charge transfer (MLCT) like in $[\text{Fe}(\text{bpy})_3]^{2+}$. In this complex the charge transfer occurs from Fe(II) to the empty π^* orbitals of bpy ligand.

26. What are 'spin forbidden' and 'spin allowed' transitions?

Ans. Any transition for which $\Delta S \neq 0$ is *strongly forbidden*; that is, to be allowed, a transition must involve no change in spin state.

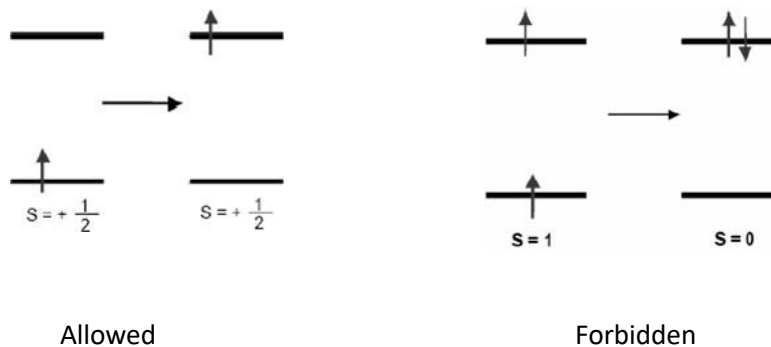

27. Why is $[\text{Mn}(\text{H}_2\text{O})_6]^{2+}$ colourless while MnO_4^- intensely coloured?

Ans. $[\text{Mn}(\text{H}_2\text{O})_6]^{2+}$ has a d^5 metal ion and is a high-spin complex. Electronic transitions are not only Laporte-forbidden, but also spin-forbidden. The dilute solutions of Mn^{2+} complexes are therefore colorless.

MnO_4^- is intensely colored even though they have metal ions without electrons in the d orbitals. The color of these complexes is not due to d-d transitions, but due to charge transfer.

28. Using CFSE indicate whether MnCr_2O_4 is a normal or inverse spinel.

Ans. MnCr_2O_4 is a type of spinel compound that contains both Mn and Cr ions. Spinel compounds can be either normal or inverse, depending on the distribution of metal ions in the crystal structure.

In a normal spinel, the divalent metal ions occupy the octahedral sites, while the trivalent metal ions occupy the tetrahedral sites.

In an inverse spinel, the opposite is true: the divalent metal ions occupy the tetrahedral sites, while the trivalent metal ions occupy the octahedral sites.

CFSE of MnCr_2O_4 is 24 Dq. This indicates that it is a normal spinel, as the CFSE of an inverse spinel would be 15.5 Dq. The CFSE of a normal spinel is higher than that of an inverse spinel, due to the arrangement of the metal ions in the crystal structure.

29. What is the importance of CFSE in spinel compounds?

Ans. The CFSE of spinel compounds plays a crucial role in determining their magnetic, electrical, and optical properties. It can also affect their stability and reactivity. By understanding the CFSE of a spinel compound, we can gain insight into its behavior and potential applications in various fields.

30. VO_4^{3-} is white, CrO_4^{2-} is yellow and MnO_4^- is purple. Explain the trend of colour in these complexes.

Ans. The isoelectronic ions VO_4^{3-} (colorless), CrO_4^{2-} (yellow), and MnO_4^- (purple) all have intense charge transfer transitions. The wavelengths of these transitions increase in this series, with MnO_4^- having its charge transfer absorption at the longest wavelength. Suggest a reason for this trend.

31. A coordination compound with formula $\text{CoCl}_3(\text{NH}_3)_4$ does not liberate NH_3 but precipitates one Cl^- ion as AgCl . Give IUPAC name and write structural formula of compound.

Ans. Since, it does not liberate ammonia, the 4 NH_3 groups are coordinated to Co. In order to satisfy the coordination number of Co, two chlorides are also coordinated. Therefore, the formula of the complex compounds is $[\text{Co}(\text{NH}_3)_4\text{Cl}_2]\text{Cl}$ and its IUPAC name is 4 tetraammine dichloro cobalt(III) chloride.

Application-based Additional questions:

32. In the crystal structure of CuF_2 , the Cu^{2+} ion is six coordinate with four F^- ions at a distance of 1.93 \AA and two F^- ions at a distance of 2.27 \AA . Explain.

Ans. Cu^{2+} d^9 significant JT distortion. Leading to 'z out' resulting in tetragonal distortion .

33. Predict the complexes which have significant tetragonal distortion:

$\text{K}_2[\text{PdCl}_6]$, $[\text{Co}(\text{Phen})_3]^{2+}$, $[\text{MnBr}_6]^{4-}$, $[\text{Cu}(\text{NH}_3)_6]^{2+}$ and $[\text{Cr}(\text{H}_2\text{O})_6]^{2+}$

Ans. Significant JT distortion means degeneracy in the e_g orbitals. $[\text{Co}(\text{Phen})_3]^{2+}$

LS d^7 One unpaired e

$[\text{Cu}(\text{NH}_3)_6]^{2+}$ HS/LS d^9 One unpaired e

$[\text{Cr}(\text{H}_2\text{O})_6]^{2+}$ HS d^4 Four unpaired e's

II. Unsolved Short answer type questions:

1. What is a spectrochemical series?
2. What are term symbols?
3. What is CFSE?
4. What are chelates?
5. What are high spin complexes? Give example.
6. What is optical isomerism?
7. What is CFT?
8. Give examples of low-spin complexes.
9. Define stereoisomerism.
10. Give a formula to calculate magnetic moment.
11. Define coordination isomerism.
12. What is coordination sphere?
13. Explain charge transfer spectra.
14. Give formula for tetrahydrooxo plumbate (II) ion.
15. Give geometry of $[\text{Pt}(\text{NH}_3)_4]^{2+}$.
16. What is L-S coupling?
17. What are strong field ligands?
18. Define ligands and complex ion.
19. What are double salts?
20. Give structure of EDTA.
21. Calculate magnetic moment for d^5 configuration.
22. What is selection rules for electronic spectra?
23. What are relaxation in laporte selection rule?
24. Give limitations of CFT.
25. What is energy order of d orbital in square planar splitting?

26. Explain types of electronic transitions.
27. Explain : a) LMCT Spectra b) MLCT Spectra
28. Tetrahedral complexes are high spin? Give reason.
29. Calculate term symbol for $[\text{Ti}(\text{H}_2\text{O})_6]^{3+}$.
30. Explain crystal field splitting in tetrahedral/octahedral complexes.

31. Give applications of chelates in analytical chemistry.
32. What is CFSE? Give equation to determine CFSE for octahedral complexes and tetrahedral complexes.
33. Why experimental value of magnetic moment is less than theoretical value? Explain with example.
34. What are different selection rules for d-d transitions? Explain.
35. Calculate CFSE for $[\text{Cr}(\text{H}_2\text{O})_6]^{2+}$ ion using data $[\Delta_0 \text{ } 13900\text{cm}^{-1} \text{ and } P = 23500 \text{ cm}^{-1}]$
36. Which complexes of following pairs have a large value of Δ_0 ? Why?
 - a) $[\text{FeF}_6]^{3-}$ and $[\text{Fe}(\text{CN})_6]^{3-}$
 - b) $[\text{Co}(\text{NH}_3)_6]^{3+}$ and $[\text{Co}(\text{NH}_3)_6]^{2+}$
37. What is geometrical isomerism? Explain it in octahedral complexes of type Ma_4b_2 and $\text{M}(\text{AA})_2\text{b}_2$.
38. Explain structure and magnetic properties of complex ion on the basis of VBT $[\text{FeF}_6]^{3-}$.
39. Identify coordination number, oxidation state, and EAN of CMI in following compounds.
 - a) $[\text{Fe}(\text{CN})_6]^{4-}$
 - b) $\text{k}[\text{PtCl}_5(\text{NH}_3)]$
40. What is structural isomerism? Explain type of structural isomerism.
41. What are chelates? Give its classification and any two applications.
42. Explain L-S coupling scheme in details.
43. Explain crystal field splitting in square planar complexes.
44. What is optical isomerism? Explain $\text{Ma}_2\text{b}_2\text{c}_2$ and $\text{M}(\text{AA})_3$.
45. Explain CFT with its limitation.
46. Give application of CFT.
47. Explain factors affecting crystal field splitting in octahedral complexes.
 - a) Nature of cation
 - b) Nature of ligands
48. Explain spectrum of $[\text{Ti}(\text{H}_2\text{O})_6]^{3+}$ complex.
49. Give electronic configuration of $[\text{Mn}(\text{H}_2\text{O})_6]^{3+}$ in t_{2g} and e_g orbitals and calculate its CFSE value.
50. What are organometallic compounds? Give two examples.

Module II: Organic Structure and Reactivity (8 Lectures)

Aromaticity, Geometrical isomerism: *cis-trans*, E/Z, and syn-anti isomerism; Optical isomerism & Chirality; Wedge, Fischer, Newmann and Sawhorse projection formulae and interconversions; D/L, R/S nomenclature system; Conformational studies of n-butane.

Addition, Elimination, Substitution and Rearrangement reaction.

Aromaticity

Let us now return to the structure of benzene. Benzene is unusually stable for an alkene and is not normally described as an alkene at all. For example, whereas normal alkenes readily react with bromine to give dibromoalkane *addition* products, benzene reacts with bromine only with difficulty—it needs a Lewis acid catalyst and then the product is monosubstituted benzene and not an addition compound. Bromine reacts with benzene in a substitution reaction (a bromine atom replaces a hydrogen atom), *keeping the benzene structure intact*. This ability to retain its ring structure through all sorts of chemical reactions is one of the important differences of benzene compared to alkenes and one that originally helped to define the class of aromatic compounds to which benzene belongs. When *cis*-cyclooctene is hydrogenated, 96 kJ mol⁻¹ of energy is released. Cyclooctatetraene releases 410 kJ mol⁻¹ on hydrogenation. This value is approximately four times one double bond's worth, as we might expect. However, whereas the heat of hydrogenation for cyclohexene is 120 kJ mol⁻¹, on hydrogenating benzene, only 208 kJ mol⁻¹ is given out, which is much less than the 360 kJ mol⁻¹ that we would have predicted. This is shown in the energy level diagram below.

The difference between the amount of energy we expect to get out on hydrogenation (360 kJ mol⁻¹) and what is observed (208 kJ mol⁻¹) is about 150 kJ mol⁻¹. This represents a crude measure of just how extra stable benzene really is relative to what it would be like with three localized double bonds. The amount of energy by which benzene is stabilized compared with the hypothetical cyclohexatriene should be called as **delocalization energy** or **resonance energy**.

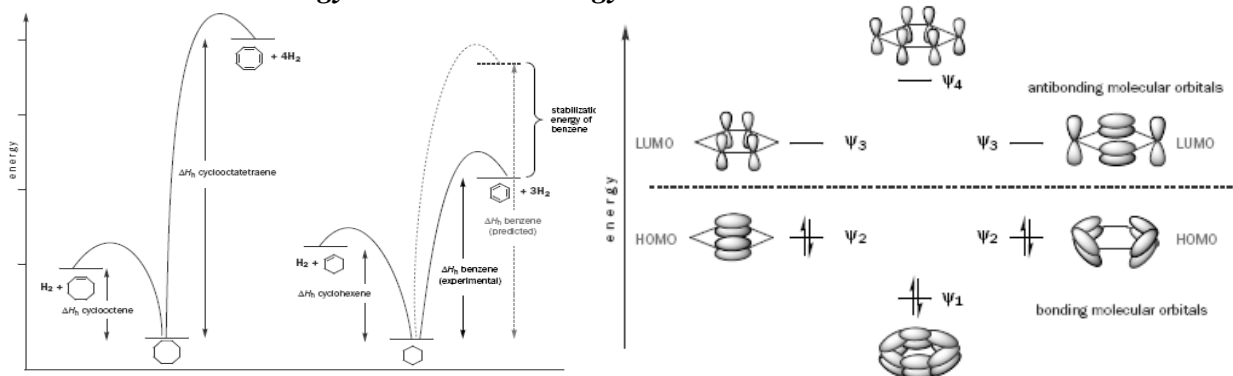

Hückel's rule

Planar, fully conjugated, monocyclic systems with $(4n + 2)$ π electrons have a closed shell of electrons all in bonding orbitals and are exceptionally stable. Such systems are said to be aromatic. Analogous systems with $4n$ π electrons are described as anti-aromatic, and those molecule are much less stable than even non aromatic compound.

In order to understand the origin of this stabilization, we must look at the molecular orbitals. We can think of the π molecular orbitals of benzene as resulting from the combination of the six p orbitals. We have already encountered the molecular orbital lowest in energy with all the orbitals combining in-phase. The next lowest molecular orbital will have one nodal plane. How can we divide up the six atoms symmetrically with one nodal plane? There are two ways depending on whether or not the nodal plane passes through a bond or an atom.

Benzene has six π electrons, which means that all its bonding molecular orbitals are fully occupied giving a closed shell structure. Cyclooctatene (COT), on the other hand, has eight electrons. Six of these fill up the bonding molecular orbitals but there are two electrons left. These must go into the degenerate pair of nonbonding orbitals. Hund's rule would suggest one in each. Therefore this planar structure for COT would not have the closed shell structure that benzene has—it must either lose or gain two electrons in order to have a closed shell structure with all the electrons in bonding orbitals. This is exactly what we have already seen—both dianion and dication are planar, allowing delocalization all over ring, whereas COT adopts a nonplanar tub shape with localized bonds.

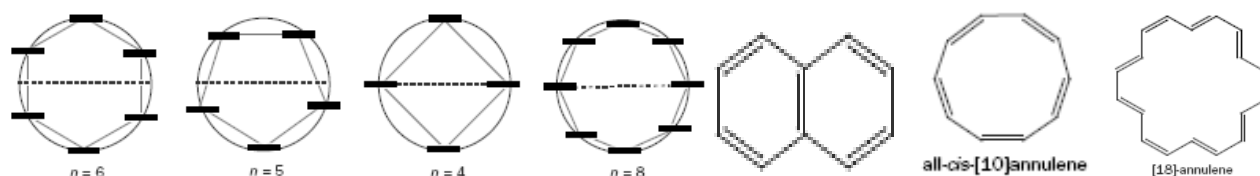

The ions or heterocyclic or fused cyclic compounds having $(4n + 2) \pi$ electrons is also aromatic system. In the heterocyclic compounds pyrrole, furan and thiophene, four pi electrons are contributed by the two double bonds in the ring while two electrons are contributed by the hetero atom. As for example:

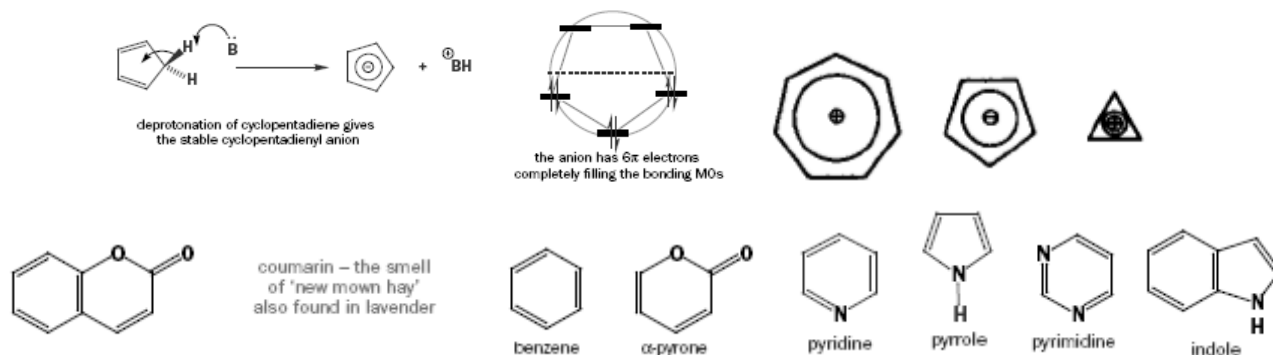

Isomerism in organic compounds

One of the striking features of organic compounds is that they exhibit isomerism. Compounds having the same molecular formula and molecular mass but having different characteristics are called isomers. This phenomenon is called isomerism. The relative position of different atoms or groups in these isomers is different and that causes the difference in properties. Isomerism may be classified into two types; 1. Structural isomerism and 2. Stereoisomerism.

1. Structural isomerism. In this type of isomerism, the molecules differ in the structural arrangement of the atoms or groups. If two or more compounds differ in the relative arrangement of atoms in the molecule, they are said to be structural isomers and this phenomenon is known as structural isomerism. There are different kinds of structural isomerisms as under:

(i) **Chain isomerism or Nuclear isomerism.** If different compounds of the same class of organic compounds, having the same molecular formula, differ in the structure of carbon chain, they are called chain isomers. Examples of this type of isomerism are:

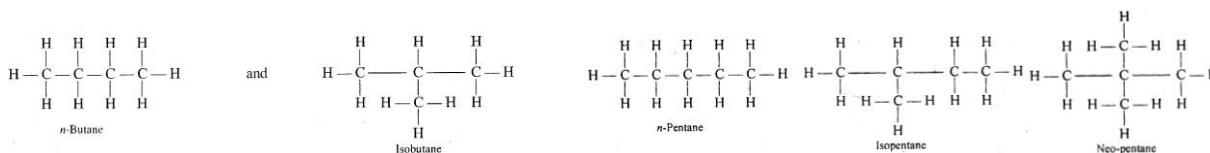

(a) Mol Formula = C_4H_{10}

(b) Mol Formula: C_5H_{12}

(ii) *Position isomerism*. If different compounds, belonging to some homologous series, with same molecular formula have same carbon skeleton but differ in the position of substituent or functional group; these are known as position isomers. Examples of this type of isomers are:

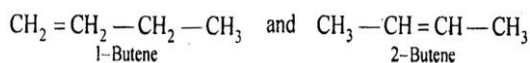
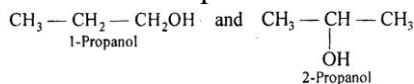

(a) Mol Formula = C_3H_8O

(b) Mol Formula: C_4H_8

(iii) *Functional isomerism*. Different compounds, with same molecular formula but different functional groups are known as functional isomers. For example:

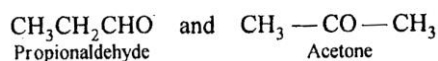
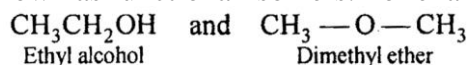

(a) Mol Formula = C_2H_6O

(b) Mol Formula: C_3H_6O

(iv) *Metamerism*. This is a special kind of structural isomerism in which different compounds, with same molecular formula, belong to same homologous series but differ in "the distribution of alkyl groups around a central atom.

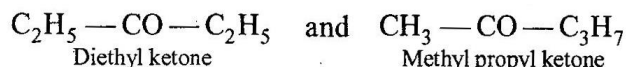
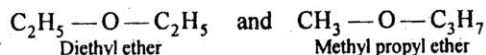

(a) Mol Formula = $C_4H_{10}O$

(b) Mol Formula: $C_5H_{10}O$

(v) *Tautomerism*. Compounds whose structures differ in the arrangement of atoms but which exist simultaneously in dynamic equilibrium with each other are called tautomers. This phenomenon is called tautomerism. In most of the cases tautomerism is due to shifting of a hydrogen atom from one carbon (or oxygen or nitrogen) to another with the rearrangement of single or double bonds. For example: There are several types of tautomerism.

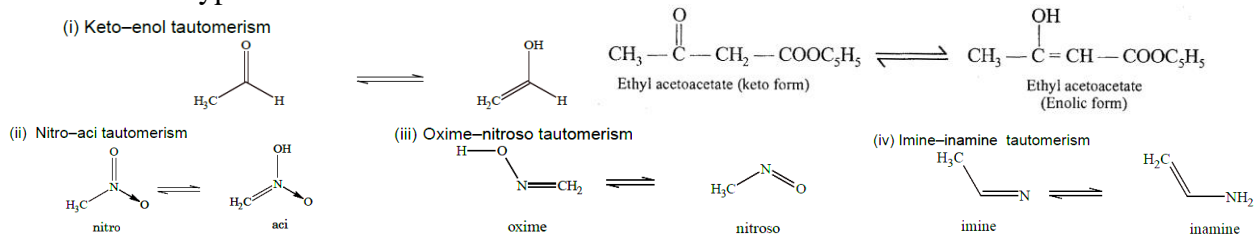

2. Stereoisomerism. Here the isomers possess the same structural arrangement but differ with respect to the arrangement of atoms or groups in space. Compounds having different three-dimensional relative arrangement of atoms in space are called stereoisomers. This phenomenon is called stereoisomerism. These compounds are said to have different configurations or conformations, i.e., (i) Geometrical isomerism, (ii) Optical isomerism (i and ii configurational) and (iii) Conformational isomerism.

(i) Geometrical isomerism

Isomers which possess the same molecular and structural formula but differ in arrangement of atoms or groups in space around the double bond (or where the rotation is frozen) are known as geometrical isomers and the phenomenon is known as geometrical isomerism. Compound will show geometrical isomerism if it fulfills the following two conditions:

(i) The rotation about two adjacent atoms in the molecule should be frozen (geometrical isomer).

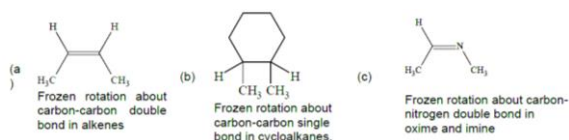

(ii) Both substituents on each carbon should be different about which rotation is frozen (conformation). The nomenclature of geometrical isomers should be followed as below;

(i) *cis-trans nomenclature*. The necessary and sufficient condition for this type of isomerism is that 'a' and 'b' in Cab=Cab must be non-equivalent. For the molecule type Cab=Cab or Cab=Cac, the term 'cis' is used in which similar groups are placed on the same and 'trans' is used for the isomer in which the similar groups are on opposite sides. For example:

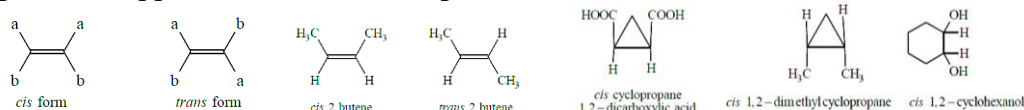

(ii) *syn-anti nomenclature*. *syn/anti* describes relationship between two substituents in an acyclic system (longest chain on zig zag) Geometrical isomerism due to restricted rotation around $>C=N$ bond. The important class of compounds exhibiting geometrical isomerism due to $>C=N$ bond are as follows. In aldoxime, when hydrogen and hydroxyl group are on the same side, the isomer is known as *syn* (analogous to *cis*) and when these groups are on the opposite sides, the isomer is known as *anti* (analogous to *trans*). Similarly, azo compounds show geometrical isomerism.

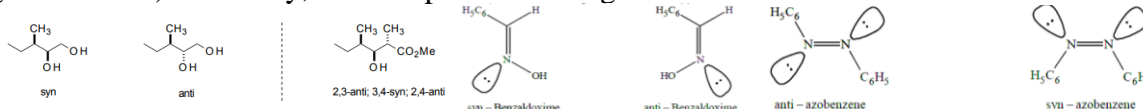

To explain the reactions mechanism the nomenclature is frequently used. For example, *Syn* addition is the addition of two substituents to the same side (or *face*) of a double bond or triple bond, resulting in a decrease in bond order but an increase in number of substituents. Generally, the substrate will be an alkene or alkyne.

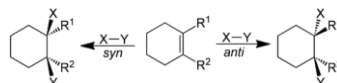

(iii) *E-Z nomenclature*. If the three or four substituents are different around $>C=C<$ the above two nomenclature leads to ambiguity and some time to total confusion. An easy solution to the problem is the use of *E-Z* designation by arranging the pair of substituents as per Cahn-Ingold-Prelog (CIP) sequence. Then if the groups of higher priority are on same side then the name is 'seq-cis' and if in opposite the name is 'seq-trans'. Letter the name has been modified by two shorter symbol 'Z' (from the German *zusammen* means together) for 'seq-cis' and 'E' (from the German *entgegen* means across) for 'seq-trans'. The *E,Z* should be used as prefix to the olefin name. The Cahn-Ingold-Prelog (CIP) sequence rule (including standard sub-rules) is as follows

- (0) Nearer end of an axis or a plane precedes farther end (proximate rule) (axial/planar chirality)
- (1) Higher atomic number precedes lower, e.g., $S > F > O > N > C > H$ etc.
- (2) Higher atomic mass number precedes lower, e.g., $T > D > H$ etc.
- (3) *Cis* or *Z* precedes *trans* or *E*.
- (4) Like pair precedes unlike pair, eg., $RR > RS$
- (5) *R* precedes *S*

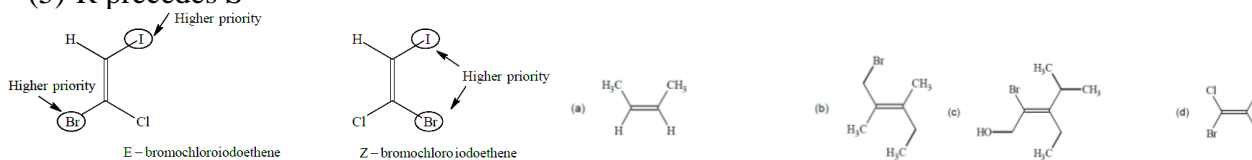

Distinction between geometrical isomers. Distinction between *cis* and *trans* isomers of a compound can be made on the basis of their physical properties such as melting point, boiling point, solubility, dipole moment etc.

(i) **Melting point:** In general, the melting point of a *trans* isomer is higher than that of the corresponding *cis* isomer. This is due to the reason that the molecules of a *trans* isomer are more symmetrical and hence fit more closely in the crystal lattice as compared to the molecules of a *cis* isomer.

(ii) **Solubility:** In general, solubility of a *cis* isomer is higher than that of the corresponding *trans* isomer. This is due to the reason that the molecules of a *cis* isomer are less tightly held in the crystal lattice.

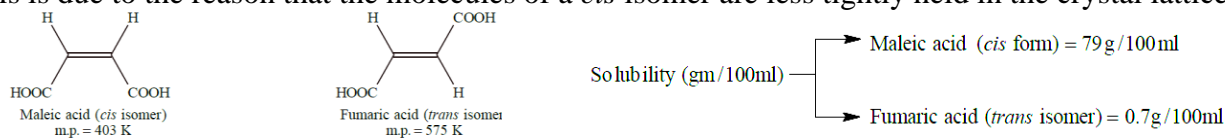

(iii) **Dipole moment:** The *cis* isomer has higher dipole moment than the corresponding *trans* isomer.

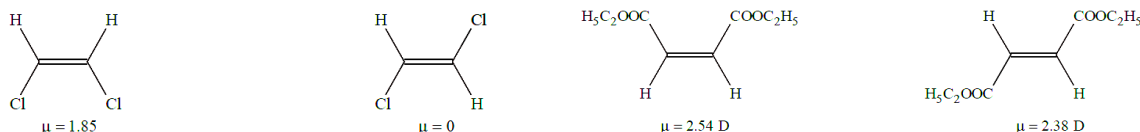

(iv) **Stability:** The *trans* isomer is more stable than *cis* isomer due to steric hindrance. Intermolecular reactions occur easily when reacting groups are close together. Hence, the *cis* isomer will form cyclic derivatives more readily as against *trans* derivatives. But this reaction will take place in only those *cis* isomers in which the substituents on two double bonded carbons are capable of intramolecular reaction with each other. Fumaric acid forms anhydride via the formation of maleic acid because at high temperature fumaric acid converts into maleic acid.

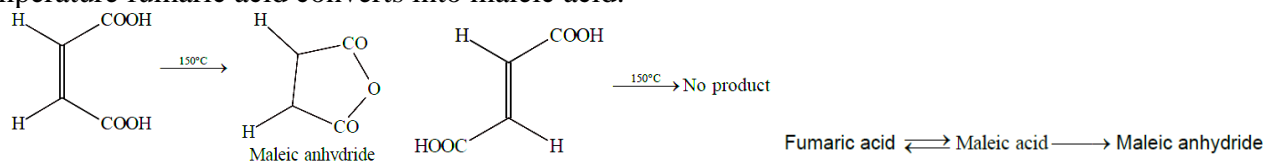

(v) **Action of heat:** On strong heating *cis* and *trans* isomers are interconvertible. This interconversion takes place as follows,

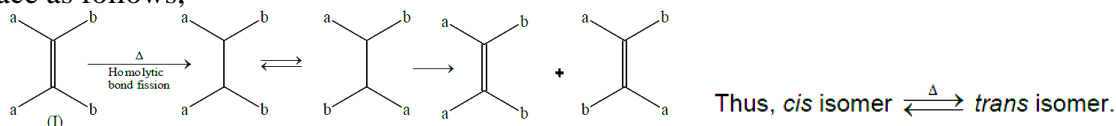

(vi) **Different chemical reactivity:** Syn addition to alkene makes *cis* form into meso and *trans* into d and l. Anti addition makes *cis* into d-l and *trans* into meso.

(ii) Optical isomerism

Compounds which rotate the plane of polarized light are known as optically active compounds and the phenomenon is known as optical activity. If a substance rotates the plane of polarized light in clockwise direction then it is dextrorotatory, (+) form or (d) form. If a substance rotates the plane of polarized light in anti-clockwise direction then it is laevorotatory, (-) form or (l) form. (d) form and (l) form can only be known by the use of polarimeter and not by the configuration of the compound.

Specific rotation. The specific rotation of an optically active substance is defined as the degree of rotation observed when the plane polarized light is passed through a tube having a path length of *l* decimetre (10 cm) and a concentration of 1 g/mole of the compound at a specified temperature and wavelength.

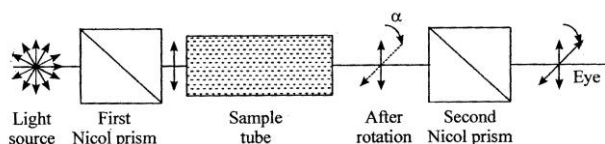

The specific rotation is calculated as

$$[\alpha]_D^t = \frac{\text{observed angle of rotation}(\alpha)}{L \times C}$$

where, L = length of polarimeter tube
 C = conc. of the substance

Chirality and asymmetric carbon. A molecule (or an object) is said to be chiral or dissymmetric, if it is not superimposable on its mirror image and the property of non-superimposability is called chirality. On the other hand, a molecule (or an object) which is superimposable on its mirror image is called achiral (non-dissymmetric or unsymmetric). Example: Alphabet P is chiral and A is achiral. Thus, for a substance to be optically active, it must be non-superimposable on its mirror image.

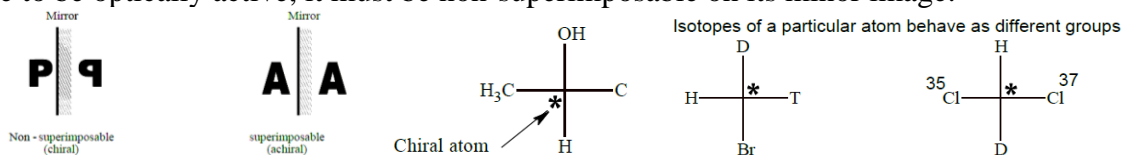

Carbon atom bonded to four different atoms or groups is called an asymmetric carbon atom or a chiral atom. A chiral atom is indicated by an asterisk (*). If a molecule contains only one chiral centre/atom, then the molecule has to be optically active (i.e. non-superimposable on its mirror image) as it will not contain any element of symmetry. Molecules containing two or more chiral centres may or may not be chiral (optically active). It is necessary to distinguish chiral and chiral centre. The word chiral is used for molecule as a whole which is optically active, whereas chiral centre is for an atom which is attached to form different atoms/groups.

The mathematical classification of symmetry properties is based on symmetry operations. “Symmetry operations” means those transformations or movements of an object, after which the object is indistinguishable from the original; comparison of the object before and after performing a symmetry operation provides no way of determining whether such an operation has been performed or not. The combination of any operations leaving the object unchanged is called an identity operation. The geometrical elements in relation to which symmetry operations are performed are called elements of symmetry. There are mainly four elements of symmetry, namely (1) axis of symmetry, (2) plane of symmetry, (3) centre of symmetry and (4) improper or alternative axis of symmetry.

Axis of symmetry, C_n : If an object (in our discussions, the object is a molecule) looks identical to the original after rotating around an imaginary axis through $(360/n)^\circ$, it is said to have an n-fold axis of symmetry, C_n . The square has four C_2 axes and one C_4 axis of symmetry. The sphere has an infinite number of C_∞ axes. An equilateral triangle (or a cyclopropane molecule) has a C_3 axis and three C_2 axes perpendicular to it. The water molecule has a C_2 axis. (Note: All objects, symmetric or not, has a C_1 axis of symmetry). The rotational axis of symmetry having the highest order (highest value of n) is called the principal axis. By convention, the object or molecule is viewed with the principal axis held vertically.

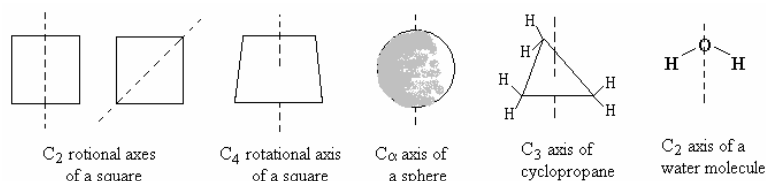

Plane of symmetry, σ : If the molecule possesses an imaginary plane such that reflection of the molecule in a double-sided mirror placed along this plane produces a configuration indistinguishable from the original, it is said to have a plane of symmetry, σ . The vertical plane of symmetry containing the principal axis is designated as σ_v , and the horizontal planes of symmetry (perpendicular to the principal axis) are designated as σ_h .

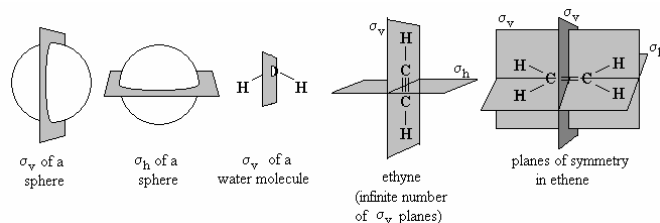

Centre of symmetry, *i*: In some molecules, there may be a point such that when a line drawn from an atom or group through this point is extended, it meets a similar atom or group on the other side at the same distance. In other words, if the origin is placed at this point, for every atom or group with coordinates (x, y, z) there is a similar atom or group at (-x, -y, -z). Such a point is called centre of symmetry. Reflection of all atoms through that point gives a molecule identical to the original. This operation is called inversion, represented by 'i'. The presence of a centre of symmetry is identical to the presence of an S_2 axis. (Verify using cyclohexane given in the previous page).

Improper axis of symmetry, S_n (rotation-reflection): If a rotation followed by reflection in a plane makes an identity operation, then the molecule is said to have an improper axis of symmetry S_n , where 'n' is the order of the rotational axis. It can be shown that in such cases the order in which the operations are performed (rotation after reflection or reflection after rotation) does not matter.

ie. $S_n = C_n \times \sigma_h = \sigma_h \times C_n$. Cyclohexane illustrates this point.

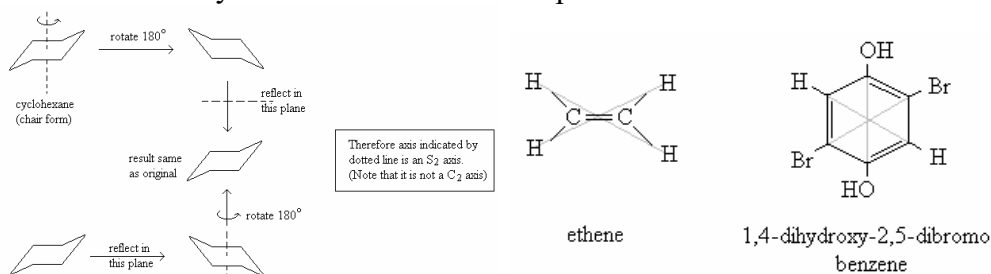

Chiral molecules having no symmetry elements whatsoever are called "asymmetric". Thus only molecules belonging to the C_1 point group are asymmetric. Eg., $CHClFBr$. Chiral molecules which contain at least one symmetry element (an axis of symmetry) but lack of alternative axis of symmetry are called dissymmetric. No. of optical isomers possible = $2^n = 2^2 = 4$

Optical isomers which are non-superimposable mirror images of each other are called enantiomers. The enantiomers have identical physical and chemical properties but rotate the plane of polarized light in opposite directions but to some extent. The stereoisomers which are not mirror images of each other are called diastereomers. The properties of diastereomers are different from those of enantiomers (which are mirror images of each other).

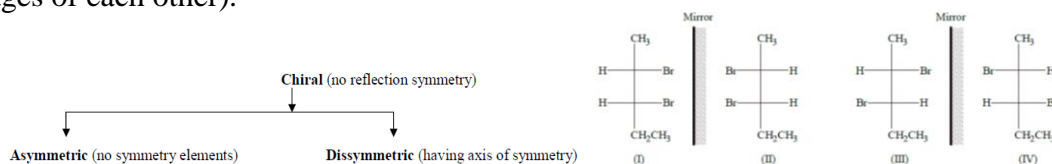

In the study of stereochemistry, it is necessary to understand the orientation of atoms and groups in a molecule in 3-dimensional space. This causes difficulties when the molecule is to be drawn on the 2-dimensional plane of paper. Therefore various methods of "projecting" a 3-dimensional molecule on a 2-dimensional plane surface have been developed to visualize the spatial distribution of atoms or groups without the use of actual molecular models.

Flying wedge representation: In this representation, a molecular model is viewed from a convenient angle so that all atoms and groups being examined can be seen. Atoms or groups that appear in a vertical plane are drawn on the paper with normal lines indicating bonds between atoms. Bonds with

atoms projecting towards the observer are indicated using a thick wedge with the flat or thick end pointing towards the observer. Bonds pointing away from the observer, which are behind the plane of the paper, are indicated by dotted lines (or sometimes outline wedges or hatched wedges with the pointed end further behind the observer). This gives a 3-dimensional appearance to the picture. The carbon atoms from which the bonds are shown are not usually indicated for clarity (it is the stereochemistry around this C atom which is being studied). But hetero atoms like N, P, O etc. must be explicitly shown.

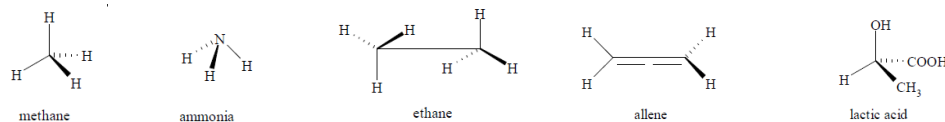

Sawhorse representation: This is a model of limited application in conformational analysis (different orientations by rotation on a single bond). The bond under consideration is held at an angle pointing away from the observer such that the atoms in front as well as those behind can be seen. The remaining three bonds on each of two C atoms are indicated by lines 120° apart in form of sawhorse.

Newman projection: This is an extremely useful representation for conformational analysis. It shows the geometry of a molecule when looking along a particular C-C bond. The C atom near the observer is shown as a point and the three atoms or groups attached to it are joined by solid lines meeting at that point. The configuration about this forward atom is fixed, and defined by the clockwise or anticlockwise disposition of the groups according to sequence rules. The atom immediately behind the near atom is represented by a circle centered on the inter-nuclear axis. The atoms or groups connected to it are attached to the circle. The angle marked as θ is called the dihedral angle. Varying the dihedral angle by rotating the rear atom on the bond changes the molecular geometry.

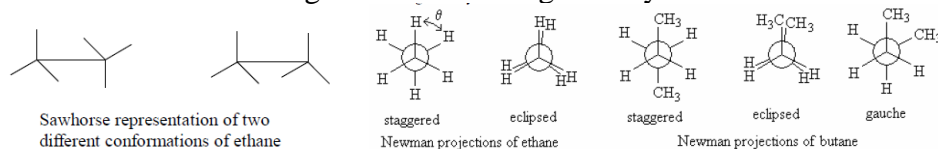

Fischer projection: This is of great help in understanding the absolute configuration around an asymmetric carbon atom when drawn on the plane of paper by following certain rules. It is used mostly in the study of the structure of sugars. In Fischer projection, one observes the asymmetric carbon atom in such a way as to see the longest carbon chain vertically and bending backward, with the most oxygenated carbon atom placed at the top. The four atoms or groups on the asymmetric carbon atom are placed at right angles in the form of a cross. By agreement, the groups above and below are considered to lie below the plane of the paper. The groups placed horizontally on the left and right lie above the plane pointing towards the observer.

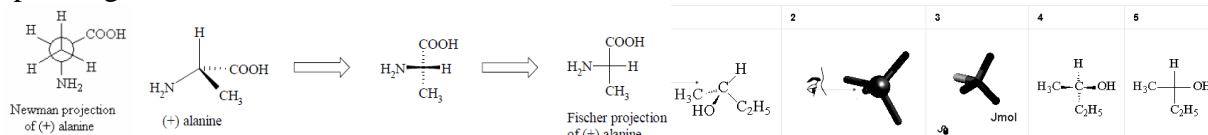

Inter-conversions. In order to convert a molecule from Fischer projection to sawhorse projection, the molecule has to be first depicted in eclipsed form. Then the steps outlined above are to be carried out in a reverse manner. In other words, again look along the C1-C2 bond as being the plane of paper, then the groups lying above the paper form the vertical line while the groups below the paper form the horizontal bonds in Fischer projection. To convert a Sawhorse projection to Newmann projection look along the C1-C2 bond through C1 such that C2 is not visible. Now the groups on C1 are same for both sawhorse and Newmann projection. The C2 carbon is replaced by a circle and the bonds emanating from C2 being retained in their actual spatial location.

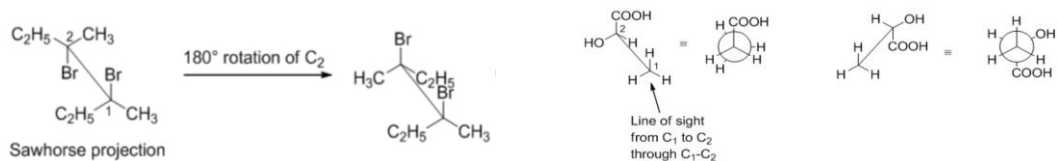

For example, to convert a flying wedge projection to Fischer projection, firstly, the bonds which are supposed to be on the plane are to be decided which must be two bonds, one vertical and horizontal connected to a carbon (Figure 1). If the vertical bond to the right is chosen, and the other horizontal bond is bent to the right, the remaining vertical bond group is depicted above the plane. On the other hand, if the vertical bond to the left is chosen, and the other horizontal bond is bent to the right, the remaining vertical bond group is depicted below the plane. For example, the steps in the conversion of the flying wedge representation of (+)alanine to its equivalent Fischer projection and Newman projection is indicated below. The Fischer projection is very useful when more than one asymmetric carbon atoms are present in the molecule, eg., sugars. It should be noted that rotation of the Fischer projection by 90° on the plane of the paper changes the configuration to the mirror image.

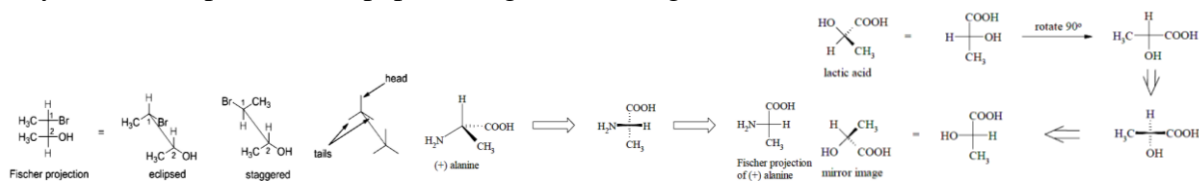

Nomenclature. We know that there are two enantiomers of glyceraldehyde, A and B shown below: One of them rotates the plane of polarized light to the left and the other to the right. But which is which? Relating the rotation to the correct structure gives the absolute configuration of the isomers. Calculation of the optical rotation of a compound of known configuration can be carried out, in principle, by using a quantity called bond polarisability. It is a measure of the response of the electrons in bonds to electric field gradients. But the calculation is very complex and is of not much use at present. Relative determination of absolute configuration of the molecule may be done as followings;

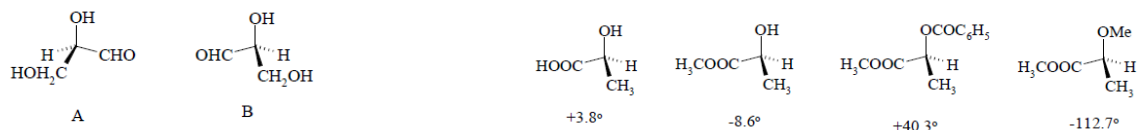

D/L nomenclature. Before 1951, there was no method available for determining the absolute configuration of a compound so, the relative configuration were established with respect to glyceraldehyde chosen as the arbitrary standard. The two enantiomers of this compound were designated D and L symbols. In this system, all sugars whose Fischer projection formula shows the -OH group on the chiral carbon atom adjacent to the terminal CH_2OH group on the right hand belong to the D-series. Similarly, if -OH is on the left hand side, then the sugar belongs to L-series. It is important to mention here that there is relation between configuration and sign of rotation.

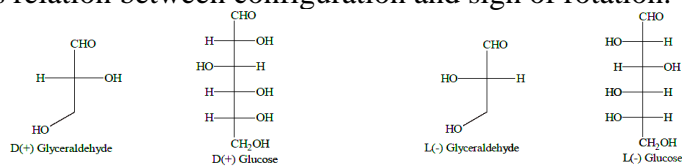

R/S nomenclature. The limitation of the (D, L) system have however been removed by an unambiguous system developed by R.S Cahn, C.K. Ingold and V. Prelog. This system is called Cahn, Ingold, Prelog (CIP) system or simply R, S system. R (from Latin *rectus* means right) and (from Latin *sinister* means left). Any chiral carbon atom has either (R) configuration or (S) configuration. The configuration is assigned by following steps:

Step – 1: First a priority sequence is assigned to all groups attached to the carbon atom. The priority can be assigned by, the CIP rules.

Step – 2: Consider the first picture: a curved arrow is drawn from the highest priority (1) substituent to the lowest priority (4) substituent. If the arrow points in a counterclockwise direction (left when leaving the 12 o' clock position), the configuration at stereocenter is considered *S* ("Sinister" → Latin= "left"). If, however, the arrow points clockwise, (Right when leaving the 12 o' clock position) then the stereocenter is labeled *R* ("Rectus" → Latin= "right"). The *R* or *S* is then added as a prefix, in parenthesis, to the name of the enantiomer of interest. The direction is shown in both flying wedge and Fischer projection structure (the most used).

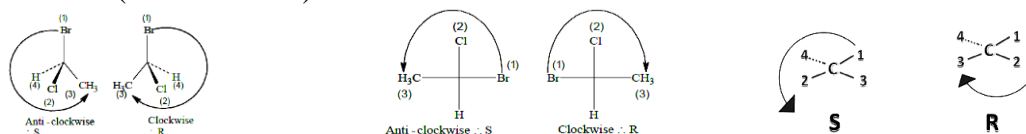

When looking at a problem with wedges and dashes, if the lowest priority atom is not on the dashed line pointing away, the molecule must be rotated. Remember that

→ Wedges indicate coming towards the viewer.

→ Dashes indicate pointing away from the viewer.

→ If (4) group is on the wedges then it should be named as opposite (mirror image) one.

Rule 1. First, examine at the atoms directly attached to the stereo-center of the compound.

1. A substituent with a higher atomic number takes precedence over a substituent with a lower atomic number. Hydrogen is the lowest possible priority substituent, because it has the lowest atomic number.
2. When dealing with isotopes, the atom with the higher atomic mass receives higher priority.
3. When visualizing the molecule, the lowest priority substituent should always point away from the viewer (a dashed line indicates this). Imagine that a pole attached to the back of the clock, so that when looking at the face of the clock the pole points away from the viewer in the the lowest priority.
4. Then, draw an arrow from the highest priority atom to the 2nd highest priority atom to the 3rd highest priority atom. Because the 4th highest priority atom is placed in the back, the arrow should appear like it is going across the face of a clock. If it is going clockwise, then it is an *R*-enantiomer; If it is going counterclockwise, it is an *S*-enantiomer.

Rule 2. If there are two substituents with equal rank, proceed along the two substituent chains until there is a point of difference. First, determine which of the chains has the first connection to an atom with the highest priority (the highest atomic number). That chain has the higher priority. If the chains are similar, proceed down the chain, until a point of difference. For example: an ethyl substituent takes priority over a methyl substituent. At the connectivity of the stereocenter, both have a carbon atom, which are equal in rank. Going down the chains, a methyl has only has hydrogen atoms attached to it, whereas the ethyl has another carbon atom. The carbon atom on the ethyl is the first point of difference and has a higher atomic number than hydrogen; therefore ethyl takes priority over methyl.

Rule 3. If a chain is connected to the same kind of atom twice or three times, check to see if the atom it is connected to has a greater atomic number than any of the atoms that the competing chain is connected to. If none of the atoms connected to the competing chain(s) at the same point has a greater atomic number: the chain bonded to the same atom multiple times has the greater priority. If however, one of the atoms connected to the competing chain has a higher atomic number: that chain has the higher priority.

Caution! Keep in mind that priority is determined by the first point of difference along the two similar substituent chains. After the first point of difference, the rest of the chain is irrelevant. When looking for the first point of difference on similar substituent chains, one may encounter branching. If there is branching, choose the branch that is higher in priority. If the two substituents have similar branches, rank the elements within the branches until a point of difference.

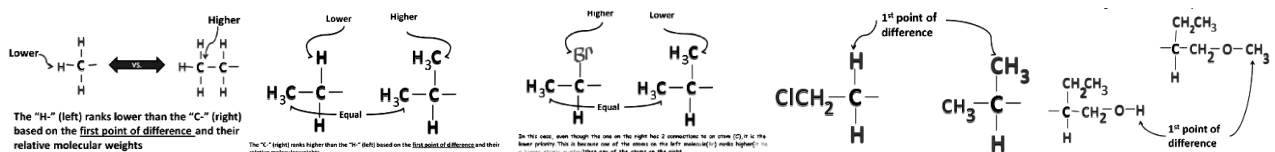

Remember that being double or triple bonded to an atom means that the atom is connected to the same atom twice. In such a case, follow the same method as above.

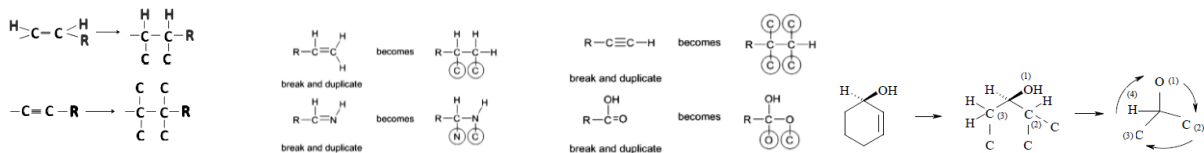

PROBLEMS

Are the following R or S?

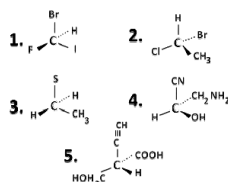

SOLUTIONS

1. S: $I > Br > F > H$. The lowest priority substituent, H, is already going towards the back. It turns left going from I to Br to F, so it's a S.
2. R: $Br > Cl > CH_3 > H$. You have to switch the H and Br in order to place the H, the lowest priority, in the back. Then, going from Br to Cl, CH_3 is turning to the right, giving you a R.
3. Neither R or S: This molecule is achiral. Only chiral molecules can be named R or S.
4. R: $OH > CN > CH_2NH_2 > H$. The H, the lowest priority, has to be switched to the back. Then, going from OH to CN to CH_2NH_2 , you are turning right, giving you a R.
5. (S): $-COOH > -CH_2OH > C \equiv CH > H$. Then, going from $-COOH$ to $-CH_2OH$ to $-C \equiv CH$ you are turning left, giving you a S configuration.

(iii) Conformational isomer

If two different 3D arrangements in space of the atoms in a molecule are interconvertible merely by free rotation about bonds, they are called conformations. If they are not interconvertible, they are called configurations. Configurations represent isomers that can be separated, as previously discussed in this chapter. Conformations represent conformers, which are rapidly interconvertible and thus nonseparable. The terms "conformational isomer" and "rotamer" are sometimes used instead of "conformer."

The angle defined by X-C-C and C-C-Y plane is termed as dihedral angle. Torsional angle is an alternative term used for dihedral angle. While dihedral is measured from 0-360°, torsional angle is measured from 0-180°, as a positive value in the clockwise direction and a negative value in the anti-clockwise direction.

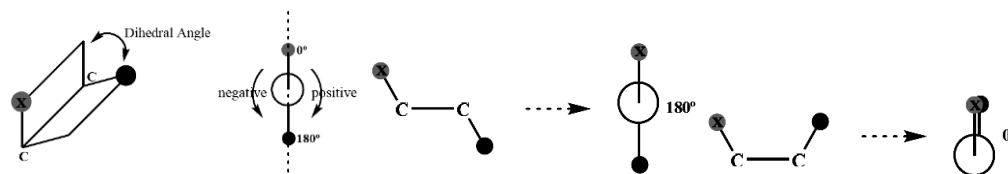

The conformational isomers are the different spatial arrangements a molecule can adopt through rotation about sigma bonds. Based on the dihedral angle between two groups of interest, a molecular conformation can be defined using the following.

Staggered - A low energy conformation where the bonds on adjacent atoms bisect each other (60° dihedral angle), maximizing the separation.

Eclipsed - A high energy conformation where the bonds on adjacent atoms are aligned with each other (0° dihedral angle).

Gauche - Description given to two substituents attached to adjacent atoms when their bonds are at 60° with respect to each other.

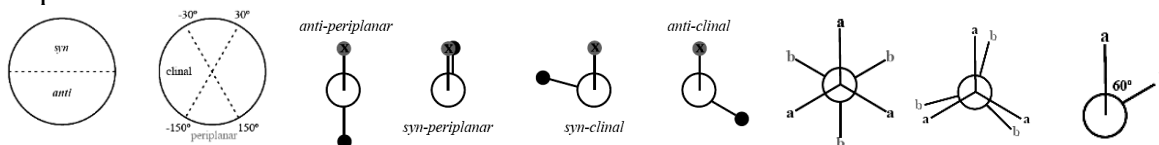

During the rotation of organic molecule we must have to consider the following stain inside the organic molecule.

Steric (non-bonded interactions) – Destabilization due to the repulsion between the electron clouds of atoms or groups. Groups compete to occupy common space. Strain due to close contact of atoms separated by four or more bonds.

Torsional – Strain resulting from eclipsing interactions between bonds on adjacent carbon atoms. Actual reasons are highly debated. Following is the possible reasons for torsional strain.

Angular – Destabilization due to distortion of a bond angle from its optimal value.

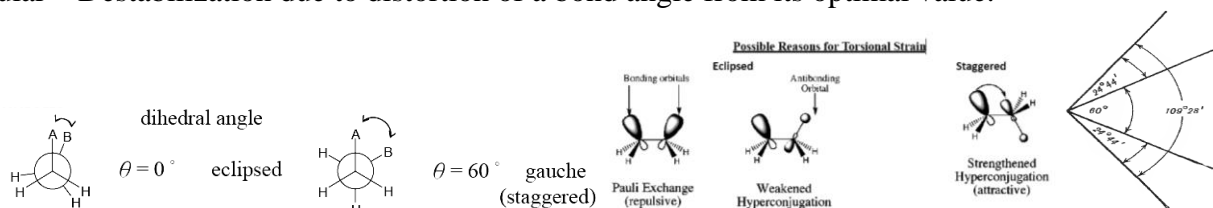

In order to better visualize these different conformations, it is convenient to use a drawing convention called the Newman projection. In a Newman projection, we look lengthwise down a specific bond of interest – in this case, the carbon-carbon bond in ethane. We depict the ‘front’ atom as a dot, and the ‘back’ atom as a larger circle.

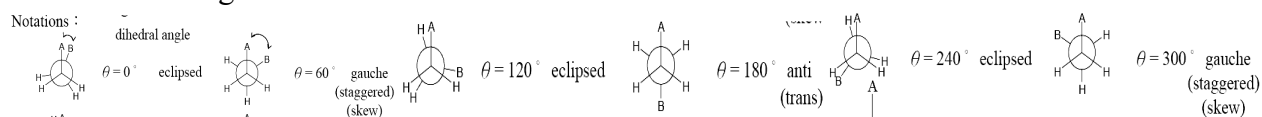

Ethane. The lowest energy conformation of ethane is called the ‘staggered’ conformation, in which all of the C-H bonds on the front carbon are positioned at dihedral angles of 60° relative to the C-H bonds on the back carbon. In this conformation, the distance between the bonds (and the electrons in them) is maximized. If we now rotate the front CH group 60° clockwise, the molecule is in the highest energy ‘eclipsed’ conformation, where the hydrogens on the front carbon are as close as possible to the hydrogens on the back carbon. This is the highest energy conformation because of unfavorable interactions between the electrons in the front and back C-H bonds, i.e., torsional strain. The energy of the eclipsed conformation is approximately 2.9 kcal/mol or 12 KJ/mol higher than that of the staggered conformation. Another 60° rotation returns the molecule to a second eclipsed conformation. This process can be continued all around the 360° circle, with three possible eclipsed conformations and three staggered conformations, in addition to an infinite number of variations in between.

Propane. In propane any one H is replaced by the CH_3 group. Thus the energy profile is exactly same with that of the ethane only difference is energy difference between eclipsed and staggered conformation is 3.3 Kcal/mol or 14 KJ/mol. Here steric strain has to consider with torsional strain.

Butane. In butane all the four conformations are possible. In anti-staggered conformation two large groups are in the opposite side having the lowest energy due to minimize the strain. In gauche- staggered conformation two large groups are 60° apart with 3.8 kJ/mol (0.9 kcal/mol) unstable energy due to steric strain between two methyl groups. Two eclipsed conformations are possible. Eclipsed conformation having 16 kJ/mol (3.8 kcal/mol) unstable energy when H and CH_3 groups of two centres are closest. Other eclipsed conformation, the highest energy or unstable conformation having 19 kJ/mol (4.6 kcal/mol) unstable energy when both CH_3 groups of two centres are closest.

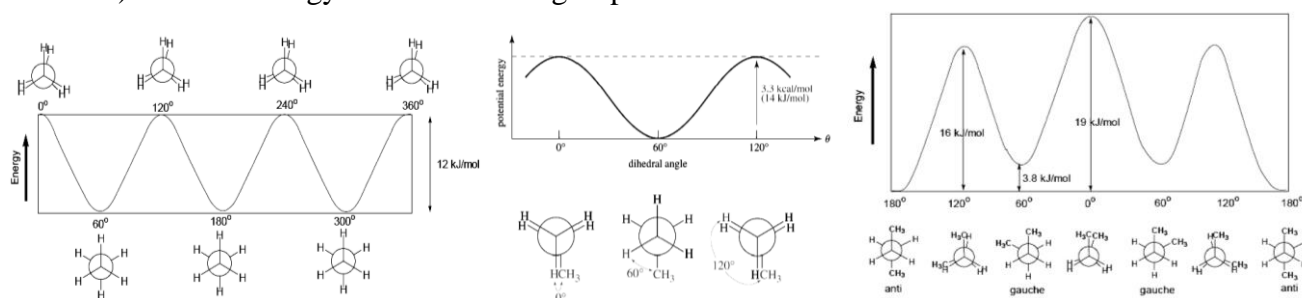

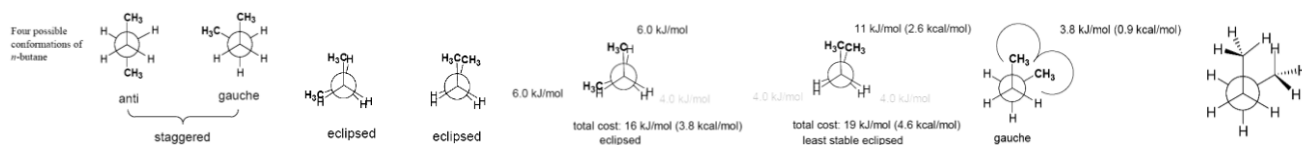

The carbon-carbon bond is not *completely* free to rotate – there is indeed a small, 3 kcal/mol barrier to rotation that must be overcome for the bond to rotate from one staggered conformation to another. This rotational barrier is not high enough to prevent constant rotation except at extremely cold temperatures. However, at any given moment the molecule is more likely to be in a staggered conformation - one of the rotational ‘energy valleys’ - than in any other state. Although the conformers of ethane are in rapid equilibrium with each other, the 3 kcal/mol energy difference leads to a substantial preponderance of staggered conformers (> 99.9%) at any given time.

Baeyer (1885) was the first to point out that the angle subtended by the corners and centre of a regular tetrahedron — $109^{\circ}28'$ —lies between the values of the angles in a regular pentagon (108°) and a regular hexagon (120°). On this observation was based the Baeyer Strain Theory. According to the Strain Theory, the valency angle can be altered from this normal value ($109^{\circ}28'$), but when altered, a strain is set up in the molecule, and the greater the deviation from the normal angle, the greater is the strain. Thus, according to Baeyer, five- and six-membered rings form most readily, and are the most stable because they involve the least strain (or distortion) from the normal valency angle.

3. Angle Strain (Bayer strain), (deviation from standard bond angle.)

Bayer’s Theory based on planer geometry

	Angle Strain/CH ₂	total Angle Strain	Exptl Strain/CH ₂
cyclopropane	24° 44'	74° 12'	9.2 kcal/mol
cyclobutane	9° 44'	38° 56'	6.55
cyclopentane	0° 44'	3° 40'	1.3
cyclohexane	-5° 16'	-31° 36'	0
cyclodecane	-17° 16'	-172° 42'	1.2

The discrepancy is due to non-planar geometry

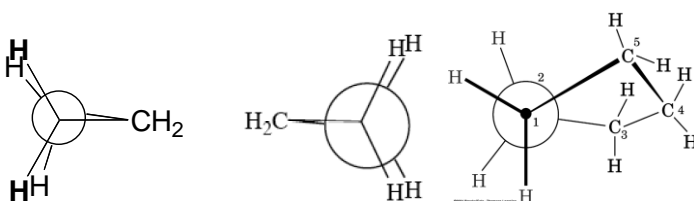

cyclopropane
 Cyclopropane C-C bond are short (1.51Å) than normal C-C bond (1.54Å)
 H-C-H bond angle open up (115°) than the value for H-C-H (106°) in the CH₃ of propane
 C-H of cyclopropane are more acidic than normal alkanes.
 → rehybridization, smaller C-C-C bond angle, more p character is used.
 Then more s character for C-H bonds.
 Strain energy of cyclopropane 27.5 kcal/mole, may come from angle strain and also the eclipsing C-H bonds (eclipsing effect, a torsional strain)

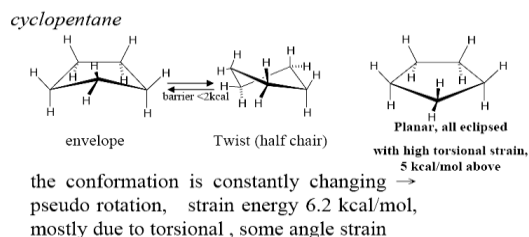
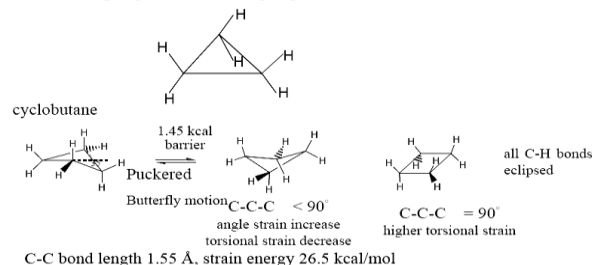

Cyclohexane. In order to be free of strain 6-membered rings are stabilize in chair conformation. As a result of simultaneous rotation about all C-C bonds, a chair conformation of cyclohexane can interconvert to another chair conformation by a ring flip. In the process, equatorial bonds become axial and vice versa. While all hydrogens in the chair conformation are staggered, four hydrogens are eclipsed in the boat conformation, which is less stable. This conformation is called the chair conformation. In the chair conformer of cyclohexane, all the bond angles are 111° , which is very close to the ideal tetrahedral bond angle of 109.5° , and all the adjacent bonds are staggered. Cyclohexane can also exist in a boat conformation, shown in Figure. Like the chair conformer, the boat conformer is free of angle strain. However, the boat conformer is not as stable as the chair conformer because some of the bonds in the boat conformer are eclipsed, giving it torsional strain. The boat conformer is further destabilized by the

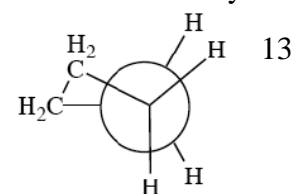

close proximity of the flagpole hydrogens (the hydrogens at the “bow” and “stern” of the boat), which causes steric strain. Each carbon has an axial bond and an equatorial bond. The axial bonds (red lines) are vertical and alternate above and below the ring. The axial bond on one of the uppermost carbons is up, the next is down, the next is up, and so on. The equatorial bonds (red lines with blue balls) point outward from the ring. Because the bond angles are greater than 90° , the equatorial bonds are on a slant. If the axial bond points up, the equatorial bond on the same carbon is on a downward slant. If the axial bond points down, the equatorial bond on the same carbon is on an upward slant. In some molecules, the twist conformation is actually preferred.

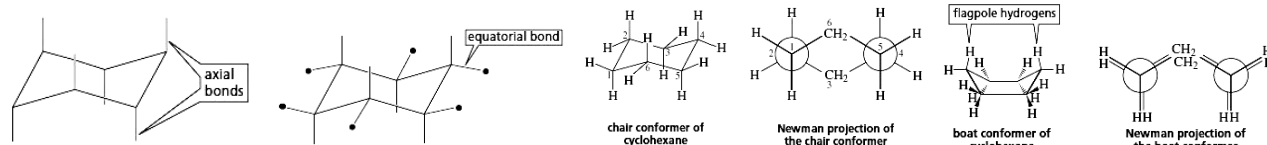

This can be explained by rejecting the postulate that all rings are planar, and by assuming that rings with six or more carbon atoms are puckered, the normal valency angle being retained and thereby producing strainless rings. To convert from the boat conformer to one of the chair conformers, one of the topmost carbons of the boat conformer must be pulled down so that it becomes the bottommost carbon. When the carbon is pulled down just a little, the twist-boat (or skew-boat) conformer is obtained. The twist-boat conformer is more stable than the boat conformer because there is less eclipsing and, consequently, less torsional strain and the flagpole hydrogens have moved away from each other, thus relieving some of the steric strain. When the carbon is pulled down to the point where it is in the same plane as the sides of the boat, the very unstable half-chair conformer is obtained. Pulling the carbon down farther produces the chair conformer. The graph in Figure shows the energy of a cyclohexane molecule as it interconverts from one chair conformer to the other; the energy barrier for interconversion is 12.1 kcal mol (50.6 kJ mol). From this value, it can be calculated that cyclohexane undergoes 105 ring flips per second at room temperature. In other words, the two chair conformers are in rapid equilibrium.

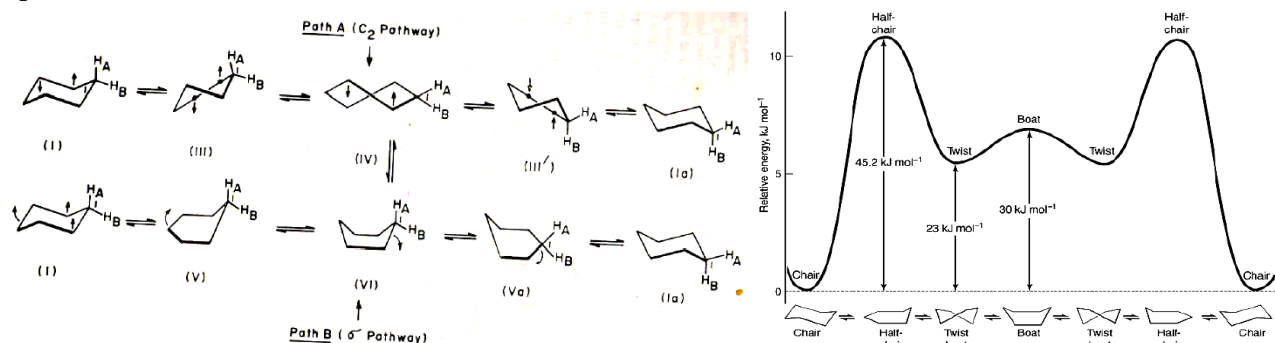

For cyclohexane there are two extreme conformations in which all the angles are tetrahedral. These are called the boat and the chair conformations and in each the ring is said to be puckered. The chair conformation is a rigid structure, but the boat form is flexible and can easily pass over to a somewhat more stable form known as the twist conformation. The twist form is 1.5 kcal/mol (6.3 kJ/mol) more stable than the boat because it has less eclipsing interaction. The chair form is more stable than the twist form by 5 kcal/mol (21 kJ/mol). In the vast majority of compounds containing a cyclohexane ring, the molecules exist almost entirely in the chair form. An inspection of the chair form shows that six of its bonds are directed differently from the other six.

3. Explain why the carbon-oxygen bond length in carbon dioxide (CO₂) is less than the theoretical value.

The difference in the bond length values can be explained by considering the following resonating structures (I-III) of CO₂. The contributing structure, I has two carbon-oxygen double bonds, however, II-III have one

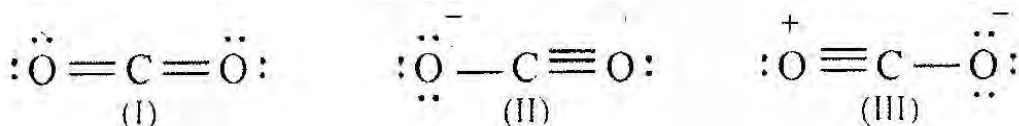

carbon-oxygen single bond and one carbon-oxygen triple bond. Carbon dioxide cannot be represented by any of the contributing structures (I-III) but by an average of all a resonance hybrid of these structures. Thus, the carbon-oxygen bond length is less than the theoretical value.

4. What are the conditions for resonance in chemistry?

Wheland has suggested the following conditions for resonance

- The contributing structures should have the same position as the constituting atoms. They only differ in the position of electrons.
- The contributing structure should have nearly the same energy.
- In the structures, like charges should not be present on adjacent atoms while unlike charges should not be widely separated.
- The resonating structures must have the same number of paired and unpaired electrons.

All the resonating structures do not contribute equally towards the hybrid. The equivalent systems have a greater contribution. Structures with more covalent bonds are more stable than those with less.

The charged contributing structure is less stable than the structure without any charge.

A structure with a negative charge on a more electronegative atom is more stable than one with a negative charge on a less electronegative atom.

5. What is the number of π electrons in the following molecules?

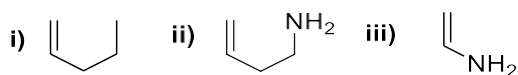

In the first two molecules, there is no conjugation. Thus, they have 2π electrons each. However, in the third molecule, the lone pair on the nitrogen participates in conjugation that's why it is considered as π electrons. Thus, molecule **iii** has 4π electrons.

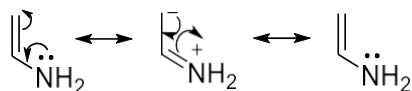

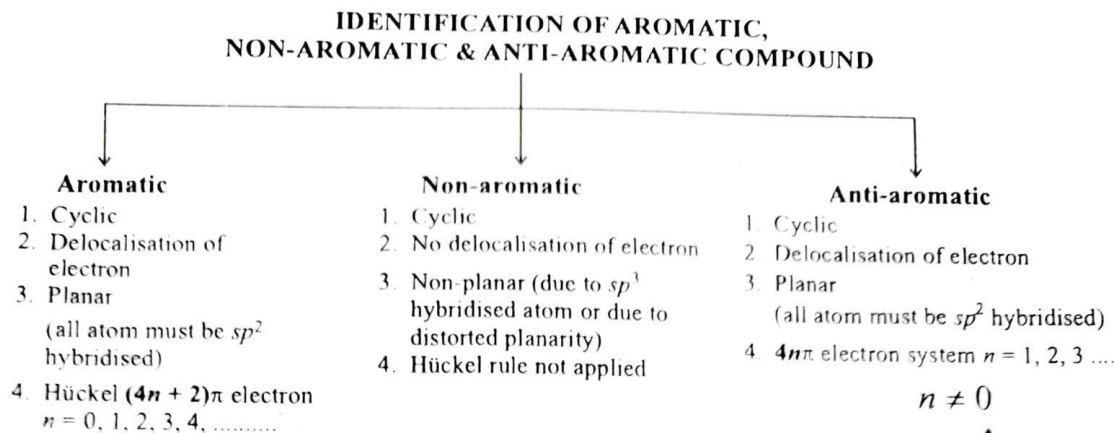

6. What are the characteristics of aromatic, non-aromatic and anti-aromatic compounds?

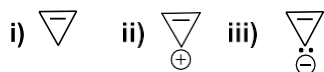

7. Classify the following molecules based on aromaticity.



 Cyclopropene	 Cyclopropenyl cation	 Cyclopropenyl anion
<ul style="list-style-type: none"> • Has 2π electrons • Satisfies $(4n+2)\pi$ rule ($n = 0$) • However, one carbon sp^3 hybridized. Thus, non-aromatic. 	<ul style="list-style-type: none"> • Has 2π electrons • Satisfies $(4n+2)\pi$ rule ($n = 0$) • All carbons are sp^2 hybridized. Thus, aromatic. <p>Hint: carbocations are sp^2 hybridized.</p>	<ul style="list-style-type: none"> • Has 4π electrons due to conjugation of electrons on the carbanion. • All carbons are sp^2 hybridized due to the delocalization of electrons. • Don't satisfy $(4n+2)\pi$ rule, however, satisfy $4n\pi$ rule ($n = 1$) • Thus, anti-aromatic.

8. Write the correct order of stability of the following carbocations with an explanation: [3]

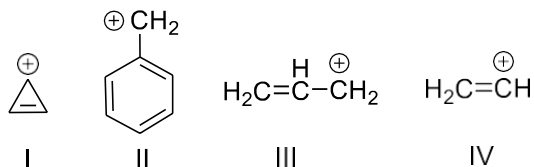

Ans: **II>I>III>IV** [Hints: II) Number of highest resonance structures with aromaticity; I and III have two resonance structures; however, I is aromatic and more stable. IV doesn't have a resonance structure and is unstable.]

9. Cyclopentadiene is acidic, explained using the concept of aromaticity. [3]

II. Stereochemistry

1. Identify the correct stereochemistry E/Z in the following compound.

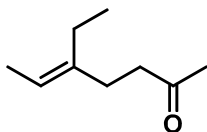

- a) (E)
b) (Z)
d) none of the above
2. Identify the correct stereochemistry E/Z in the following compound.

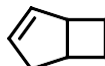

- a) (Z)
b) (E)
c) none of the above
3. Identify the correct stereochemistry E/Z in the following compound.

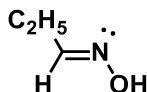

- a) (Z)
b) (E)
c) none of the above
4. Identify the erythro/threo isomer in drawn structure

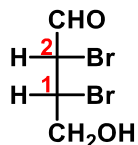

- a) erythro
b) threo
c) none
5. Identify the correct R/S configuration of C1 and C2 in drawn structure

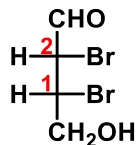

- a) C1: R and C2: S
b) C1: S and C2: R
c) C1: R and C2: R
d) none
6. Identify the correct D/L & R/S configuration in following drawn structure:

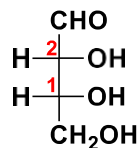

- a) L, C1: R and C2: R
- b) D, C1: R and C2: R
- c) D, C1: S and C2: S
- d) L, C1: R and C2: R

7 Identify the correct sawhorse projection of the following structure:

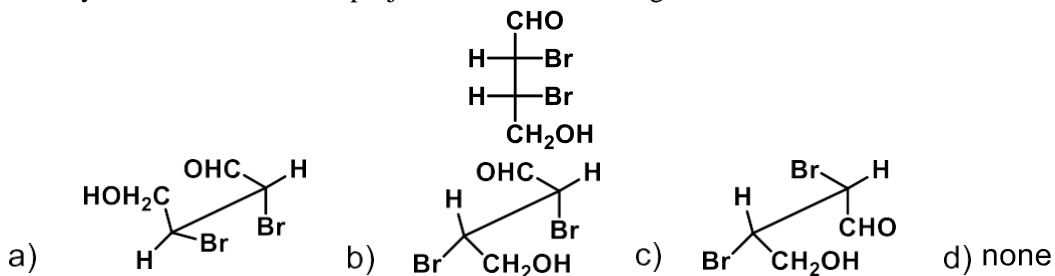

8. Identify the correct Fisher projection formula of the following Newman projection:

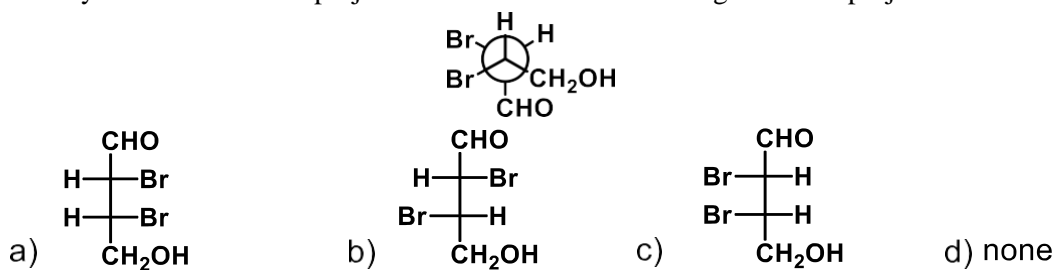

9. How many distinguished conformers are possible in following the Newman Projection Formula of Butane:

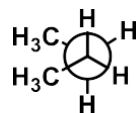

- a) 1
- b) 2
- c) 3
- d) 4

10. Identify the cis-trans isomer in 1,2-dibromocyclohexane. Both bromo groups are placed at equatorial position.

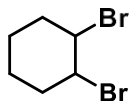

- a) cis
- b) trans
- c) none

ANSWERS for above 10 questions: 1a, 2c, 3b, 4a, 5a, 6b, 7d, 8c, 9d, 10b

Substitution (SN2 , SN1) and Elimination Reactions (E2 , & E1):

- Nucleophilic Substitution Reactions (SN2 and SN1) replace a leaving group with a nucleophile (Nu: or Nu: -)
- Elimination Reactions (E2 and E1) generate a double bond by loss of " A+ " and " B: - "
- They may compete with each other

Nucleophilic Substitution Reactions - SN2 Reaction:

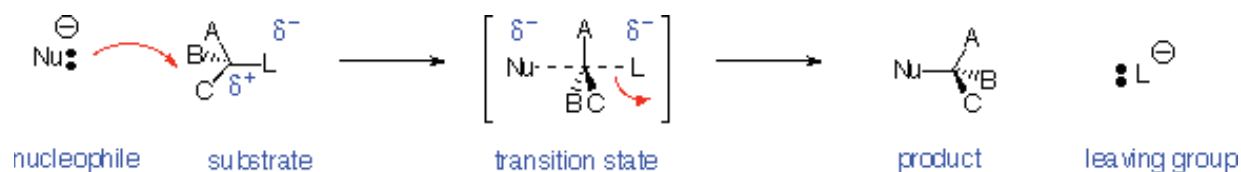

- **Reaction is:**
 - Stereospecific (Walden Inversion of configuration)
 - Concerted - all bonds form and break at same time
 - Bimolecular - rate depends on concentration of both nucleophile and substrate
 - **Substrate:**
 - Best if **primary** (one substituent on carbon bearing leaving group)
 - works if secondary, fails if tertiary
 - **Nucleophile:**
 - Best if more reactive (i.e. more anionic or more basic)
 - **Leaving Group:** Best if more stable (i.e. can support negative charge well):
 - TsO- (very good) > I- > Br- > Cl- > F- (poor)
 - RF , ROH , ROR , RNH₂ are NEVER Substrates for SN2 reactions
 - Leaving Groups on double-bonded carbons are never replaced by SN2 reactions
 - **Solvent:** Polar Aprotic (i.e. no OH) is best.
 - For example dimethylsulfoxide (CH₃SOCH₃), dimethylformamide (HCON(CH₃)₂), acetonitrile (CH₃CN).
 - Protic solvents (e.g. H₂O or ROH) deactivate nucleophile by hydrogen bonding but can be used in some case
-

Nucleophilic Substitution Reactions – SN1 Reaction:

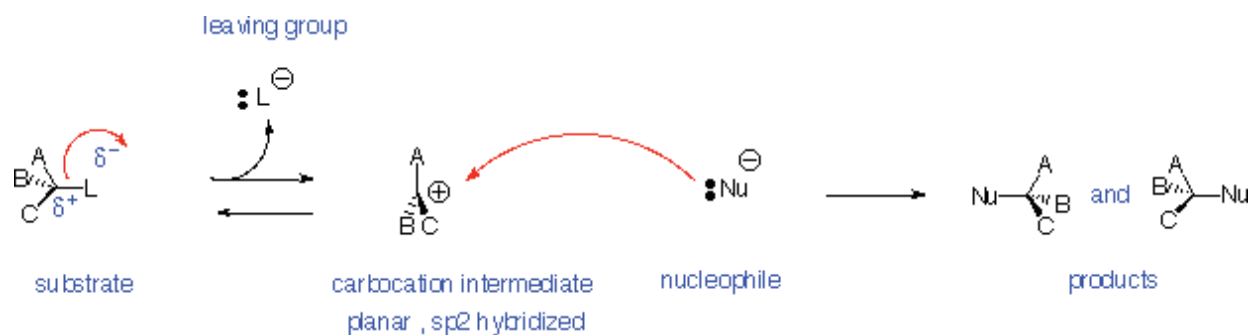

- **Reaction is:**
 - Non-stereospecific (attack by nucleophile occurs from both sides)
 - Non-concerted - has carbocation intermediate
 - Unimolecular - rate depends on concentration of only the substrate
 - **Substrate:**
 - Best if tertiary or conjugated (benzylic or allylic) carbocation can be formed as leaving group departs
 - never primary
 - **Nucleophile:**
 - Best if more reactive (i.e. more anionic or more basic)
 - **Leaving Group:**
 - Same as SN2
 - best if more stable (i.e. can support negative charge well)
 - Examples: TsO^- (very good) > I^- > Br^- > Cl^- > F^- (poor)
 - However, tertiary or allylic ROH or ROR' can be reactive under strongly acidic conditions to replace OH or OR
 - **Solvent:**
 - Same as SN2
 - Polar Aprotic (i.e. no OH) is best
 - Examples: dimethylsulfoxide (CH_3SOCH_3), dimethylformamide ($HCON(CH_3)_2$), acetonitrile (CH_3CN).
 - Protic solvents (e.g. H_2O or ROH) deactivate but can be used in some cases
-

Elimination Reactions - E2 Reaction:

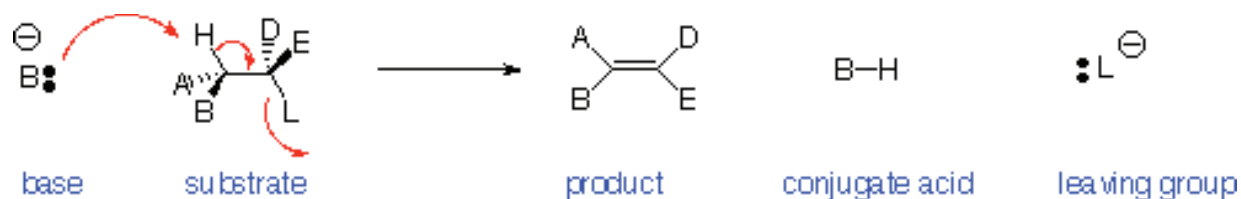

H and L are anti-periplanar

- **Reaction is:**
 - Stereospecific (Anti-periplanar geometry preferred, Syn-periplanar geometry possible)
 - Concerted - all bonds form and break at same time
 - Bimolecular - rate depends on concentration of both base and substrate
 - Favoured by strong bases

Elimination Reactions – E1 Reaction:

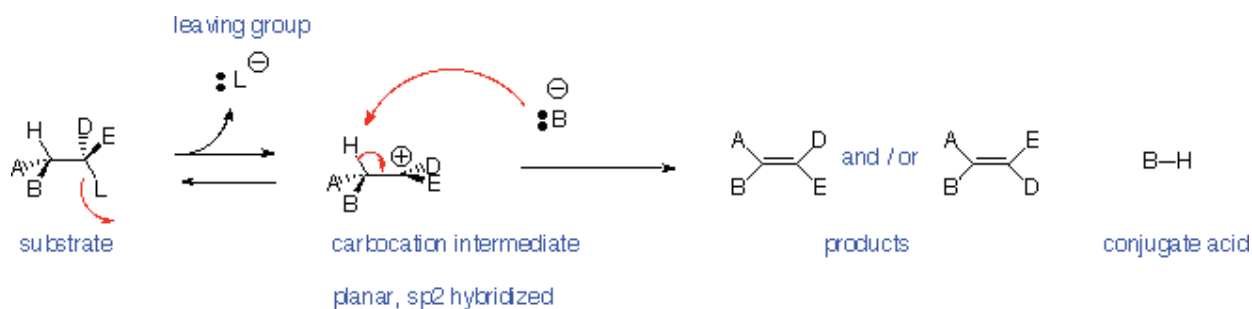

- **Reaction is:**
 - Non-stereospecific- follows Zaitsev (Saytseff) Rule
 - Non-concerted - has carbocation intermediate - favoured for tertiary leaving groups
 - Unimolecular - rate depends on concentration of only the substrate
 - Does NOT occur with primary alkyl halides (leaving groups)
 - Strong acid can promote loss of OH as H₂O or OR as HOR if tertiary or conjugated carbocation can be formed
-

Rearrangement reaction:

Types of Rearrangements

Rearrangements are divided into intramolecular and intermolecular processes. In intramolecular process, the group that migrates is not completely detached from the system in which rearrangement is taking place. In contrast, in intermolecular process, the migrating group is first detached and later re-attached at another site.

Rearrangement to Electron Deficient Carbon These reactions are classified according to the nature of group that migrates.

Carbon Migration

Wagner-Meerwein Rearrangement It is one of the simplest systems where an alkyl group migrates, with its bonding pair, to an electron-deficient carbon atom.

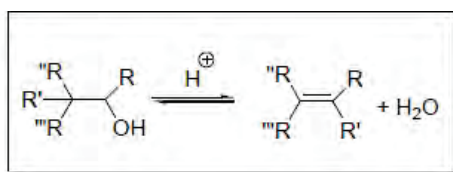

Mechanism

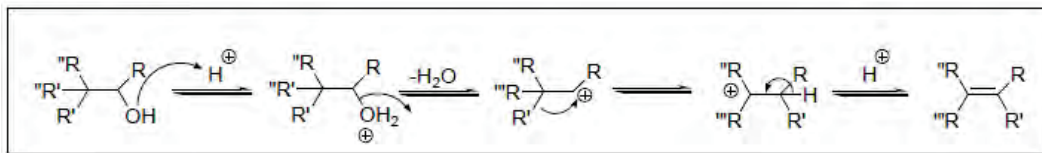

The driving force for the rearrangement resides in the greater stability of a tertiary carbocation compared to that of primary carbocation.

Features of this migration

- The carbocation may be produced by a variety of ways.
- Hydrogen can also migrate in this system.

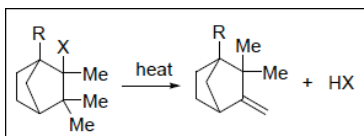

- Aryl groups have a greater migratory aptitude than alkyl group or hydrogen due to the formation of lower-energy bridged phenonium ion.

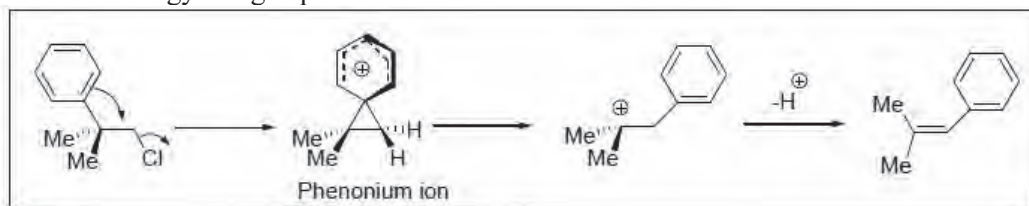

Pinacol Rearrangement

Treatment of 1,2-diols (pinacol) with acid lead to rearrangement to give ketone. Although this rearrangement fundamentally is similar to the above described Wagner-Meerwein rearrangement, but differs in that the rearranged ion, the conjugate acid of ketone, is relatively more stable than the rearranged carbocation formed in Wagner-Meerwein rearrangement. Thus, the driving force for pinacol is greater compared to Wagner-Meerwein rearrangement. However, the characteristics of the Wagner-Meerwein apply to the pinacol rearrangement.

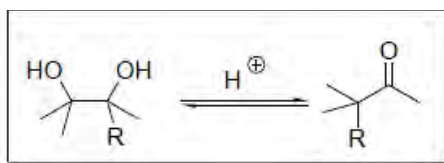

Mechanism

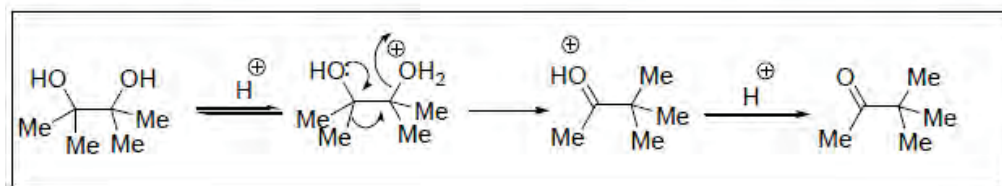

Hofmann Rearrangement This rearrangement provides an effective method for the synthesis of primary aliphatic and aromatic amines from primary amides (Scheme 1).

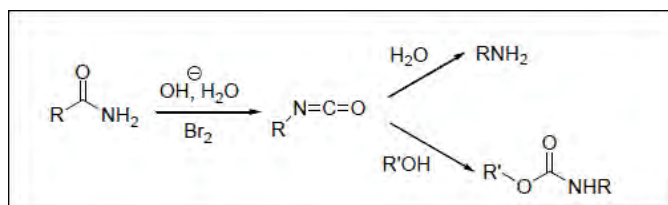

Mechanism Treatment of amide with sodium hypobromite gives *N*-bromo-amide which reacts with base to afford a conjugate base within which rearrangement takes place to give isocyanate. The formed isocyanate may be isolated in anhydrous conditions or it can be converted into amine by aqueous workup (Scheme 2).

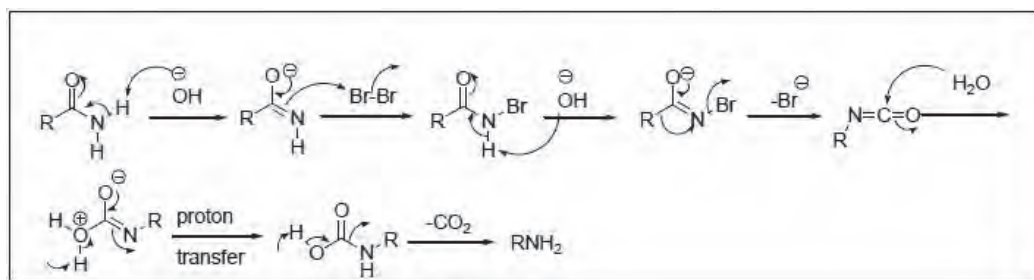

Scheme 2

Curtius Rearrangement This rearrangement describes the transformation of acyl azide into isocyanate by decomposition on heating and its application for the synthesis of primary amines, urethanes and ureas as presented in Hofmann rearrangement.

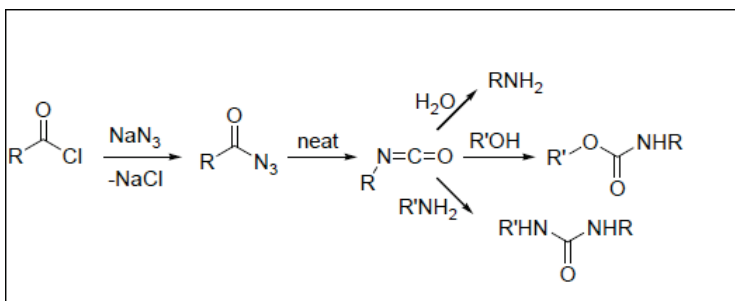

Mechanism

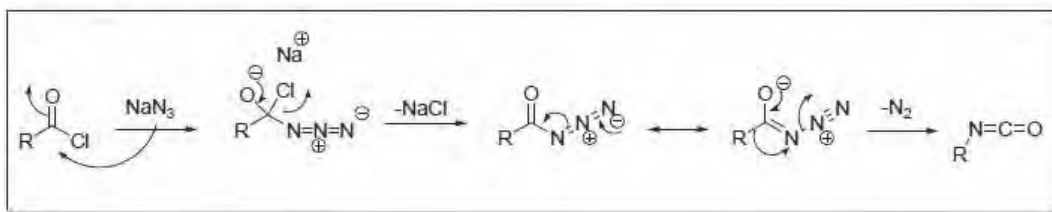

Lossen Rearrangement Ester of hydroxamic acid reacts with base to give isocyanate that could be converted into amine as shown in Hofmann rearrangement.

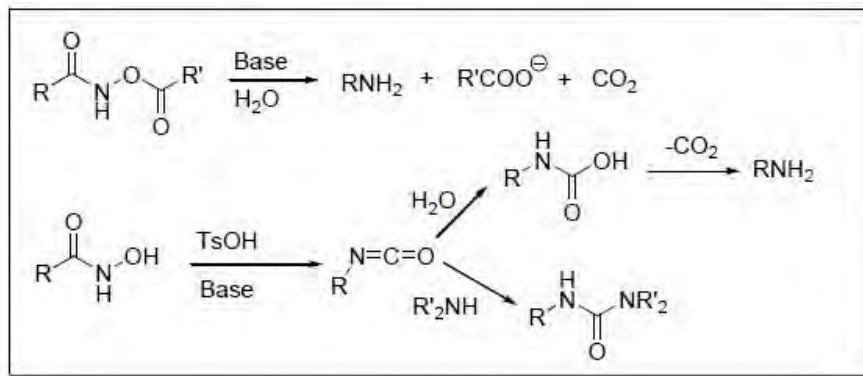

Mechanism

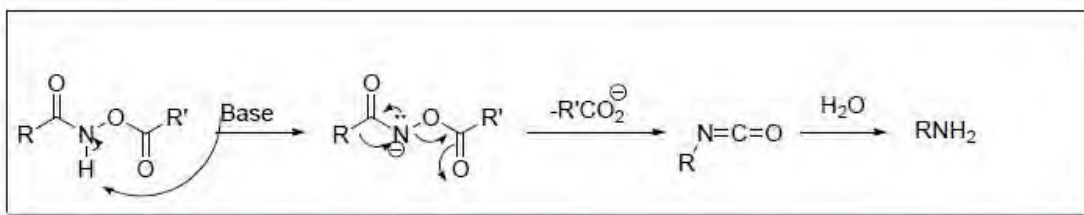

Tutorial-sheet: Chemical kinetics

1. In which types of reaction order and molecularity are equal? Explain with example.
2. Show that for parallel reactions ratio of concentration of the products at any time is constant.
3. Draw and explain the concentrations vs time plot for reactant and products of parallel reactions.
4. For consecutive reaction

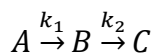

Derive the expression

$$[B] = [A]_0 \left(\frac{k_1}{k_2 - k_1} \right) \{ e^{-k_1 t} - e^{-k_2 t} \}$$

$$[C] = [A]_0 \left\{ 1 - \frac{1}{k_2 - k_1} (k_2 e^{-k_1 t} - k_1 e^{-k_2 t}) \right\}$$

Draw a graph illustrating the typical variations of A, B and C with time.

What will be the concentration of C in case of $k_2 \gg k_1$ and $k_1 \gg k_2$?

5. The half-lives of two parallel path reaction are 4 hrs and 12 hrs respectively. The average half-life for the decay of A is _____ hrs.

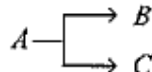

Ans: The average half-life for the decay of A is 3 hrs.

6. Derive rate constant (relaxation constant) expression for fast reactions.

7. The relaxation time for fast reaction $A \xrightleftharpoons[k_{-1}]{k_1} B$ is $10 \mu\text{s}$ and the equilibrium constant is 1×10^{-3} . Calculate the rate constant for forward and reversible reaction.

Sol. $K_{eq} = K_1/K_{-1} = 10^{-3}$ i.e., $K^{-1} \gg K_1$

$$\Gamma^* = 1/(K_1 + K_{-1}) = 1/K_{-1} = 10 \mu\text{s} = 10 \times 10^{-6} = 10^{-5} \text{ s}$$

$$K_{-1} = 10^5 \text{ s}^{-1}$$

$$\text{Since, } K_1/K_{-1} = 10^{-3}; K_1 = 10^{-3} \times 10^5 = 10^2 \text{ s}^{-1}$$

8. For consecutive reactions $A \xrightarrow{k_1} B \xrightarrow{k_2} C$ derive the equation for maximum concentration.

9. Derive the equation for half-life of parallel reactions.

10. Write down the different steps involved in the $H_2 + Br_2 = 2 HBr$ chain reaction.

11. What is steady-state approximations?

12. For the $H_2 + Br_2 = 2 HBr$ chain reaction, the rate equation is

$$\frac{d[HBr]}{dt} = \frac{k'[H_2][Br_2]^{1/2}}{1 + k''\frac{[HBr]}{[Br_2]}}$$

Find out the overall order of the reaction at the initial stage.

Ans: The overall order of the reaction is 1.5 (order 1 w.r.t. H_2 and $\frac{1}{2}$ w.r.t. Br_2).

CATALYSIS

Outline of Catalysis, Acid-base catalysis, Enzyme catalysis (Michaelis-Menten equation), Important catalysts in industrial processes: Hydrogenation using Wilkinsons catalyst, Phase transfer catalyst.

1. Define catalyst and Discuss the general characteristics of a catalyst.

Ans. Catalyst is defined as a substance, a small quantity of which alter (increase or decrease) the velocity of a chemical reaction by its mere presence, without itself undergoing any change in mass and composition at the end of the reaction.

Characteristics of catalysts:

1. A catalyst remains unchanged in mass and composition at the end of the reaction though a change in physical state, color etc. may occur.

As for example, granular MnO_2 (manganese dioxide) used as a catalyst during the decomposition of Potassium Chlorate (KClO_3), is recovered as fine powder after the reaction.

2. A small amount of catalyst is sufficient to bring an appreciable change in the velocity of the reaction. Example: The presence of even 1 mg of fine Pt powder is enough to catalyze the combination of 2.5 liters mixture of H_2 and O_2 to form water. Rate increase in the increase in the surface area of the catalyst.

3. A catalyst can exert a selective action like a key can open a particular lock. Some catalysts are very specific in respect of reaction and change of a catalyst may divert the path of the same reaction to different products.

Examples: (i) water gas (a mixture of CO and H_2) is converted to –

(a) Methanol when passed over ZnO and Cr_2O_3 at 400°C

(b) Methane when passed over a Nickel catalyst at 400°C

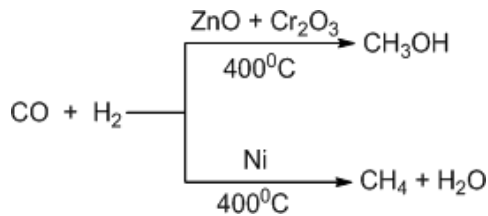

4. A catalyst can only alter the speed of the reaction but does not affect the final state of equilibrium since it alters the rate of the forward as well as backward reaction to the same extent, thereby the composition of the equilibrium remains the same.

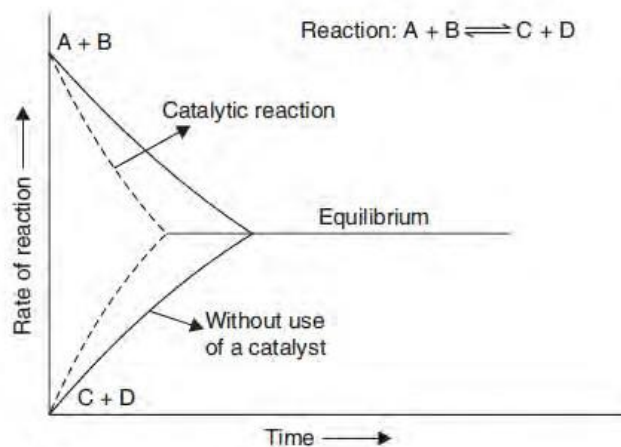

Fig. Effect of catalyst on time to attain equilibrium

5. According to Ostwald, a catalyst cannot initiate the reaction but can only decrease or increase its rate. Initiation of reactions by catalyst are rather rare but not unknown. Example- Perfectly dry H_2 and O_2 does not combine to form water even if they are left in contact for years, but in presence of little water (catalyst), the reaction proceeds quite rapidly.

6. A catalyst is most active at a particular temperature, called the optimum temperature.

2. What are the different types of catalysis? Explain with example.

Ans. Generally there are two types of catalysis-

(i) Homogenous and (ii) Heterogeneous catalysis

(A) Homogenous catalysis: In this catalysis, the catalyst is present in the same phase as the reacting substances (either in gas phase or liquid phase). Examples are given

below-

In gas phase:

(i) In the lead chamber process, for the manufacture of H_2SO_4 , nitric oxide (NO) catalyzes the oxidation of the SO_2

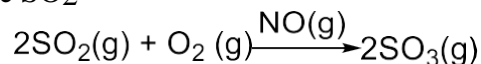

(ii) Decomposition of acetaldehyde is catalyzed by Iodine vapor

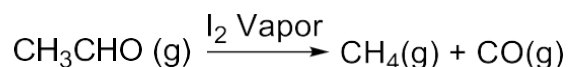

(a) In Liquid phase: In acid-base catalysis-inversion of cane sugar and hydrolysis of esters.

Acid catalysis:

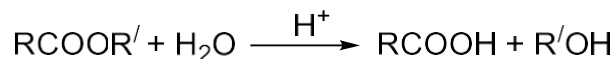
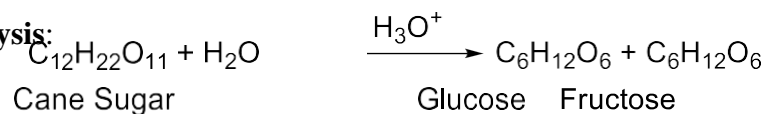

Base catalysis:

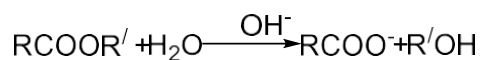

Carboxylation

(B) Heterogeneous catalysis:

In such reactions, the catalyst is present in different phase from the reacting substances and the reaction proceeds at an interface between the two discrete phases. Catalysts are usually solid and the reactants are in different phase (either liquid or gaseous).

(a) In Haber's process, for the manufacture of NH_3 , nitrogen and hydrogen gases in the volume ratio 1:3 are passed over heated iron catalyst which contains a promoter, molybdenum.

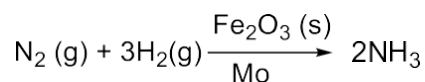

Pt

3. Define Homogenous catalysis. Explain with two homogenous catalysis reactions.

Ans. Refer Ans(2)

4. Define Heterogenous catalysis. Explain with two heterogenous catalysis reactions

Ans. Refer Ans (2)

5. Discuss the kinetic of the acid base catalysis .

Ans5.

Kinetics of acid catalyzed reaction:

Mechanism 1:

We assume that a proton is transferred from an acid AH^+ to the substrate S. The acid form the substrate SH^+ then reacts with water molecule to form the product P.

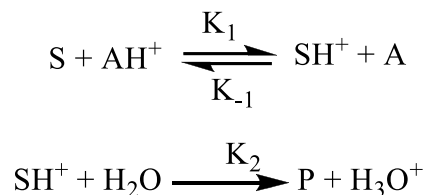

Applying steady state approximation for SH^+ , we have,

Rate of formation of SH^+ = rate of consumption of SH^+

$$K_1[S][AH^+] = K_{-1}[A][SH^+] + K_2[SH^+][H_2O]$$

For very dilute solution, concentration of $[H_2O]$ almost remain constant, so

$$K_1[S][AH^+] = K_{-1}[A][SH^+] + K_2[SH^+]$$

Solving for $[SH^+]$. We have

$$[SH^+] (K_{-1}[A] + K_2) = K_1[S][AH^+]$$

$$K_2[SH^+] = \frac{K_1 K_2 [S][AH^+]}{K_{-1}[A] + K_2}$$

The rate of formation of product is given by,

$$d[P]/dt = K_2[SH^+] = \frac{K_1 K_2 [S][AH^+]}{K_{-1}[A] + K_2}$$

Let us discuss two limiting cases,

Case I: If $K_2 \gg K_{-1}[A]$. so there is always only a small $[SH^+]$.

$$d[P]/dt = K_1[S][AH^+]$$

As the rate depends on $[AH^+]$, hence the reaction is generalized acid catalysis.

Case II: If $K_2 \ll K_{-1}[A]$, SH^+ may be considered to be in equilibrium with reactant.

$$d[P]/dt = \frac{K_1 K_2 [S] [AH^+]}{K_{-1} [A]} \times \frac{[H^+]}{[H^+]} = \frac{K_1 K_2 [S] [H^+]}{K_{-1} K}$$

Where K is the ionization constant of $[AH^+]$



From the equation the rate is proportional to the $[H^+]$, it is an example of specifically acid catalyzed reaction.

Mechanism 2:

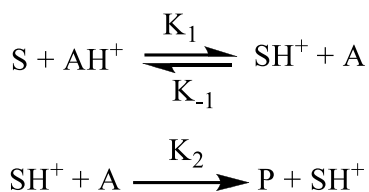

We assume that in the second step, the acid form of the substrate reacts with a base instead of water molecule.

Applying steady state approximation, $K_1[S][AH^+] = K_{-1}[A][SH^+] + K_2[SH^+][A]$

$$[SH^+] (K_{-1}[A] + K_2[A]) = K_1[S][AH^+]$$

$$[SH^+] = \frac{K_1[S][AH^+]}{K_{-1}[A] + K_2[A]}$$

The rate of the reaction is.

$$\begin{aligned} d[P]/dt &= K_2[SH^+][A] \\ &= \frac{K_1 K_2 [A][S][AH^+]}{(K_{-1} + K_2)[A]} \\ &= \frac{K_1 K_2 [S][AH^+]}{K_{-1} + K_2} \end{aligned}$$

From the above equation, it is obvious that the rate of the reaction is proportional to $[AH^+]$, it is an example of general acid catalysis.

6. Derive the Michaelis-Menten equation.

Dividing by K_1 , we get,
$$\text{Rate } (r) = \frac{K_2[E]_0 [S]}{(K_1 + K_2) + [S]} = \frac{K_2[E]_0 [S]}{K_m + [S]}$$

where,
$$K_m = \frac{K_1 + K_2}{K_1}$$

This equation is known as Michaelis-Menten equation and K_m is known as Michaelis constant.

7. Write down the characteristics of the enzymes

Ans. Enzymes are protein that can acts as enormously effective catalyst and can speed up the reaction by high factors of up to 10^{12} .

(i) They are highly specific and each enzymes catalyze a particular reaction. (Key and Lock).

(ii) All enzyme reaction exhibits maximum efficiency at optimum temperature. Above this temperature the enzymes gets denatured, thereby losing its activity.

.

(iii) Enzyme catalyzed reactions are much more sensitive to catalytic poison such as HCN, CS₂, H₂S etc. The inhibitors (or poisons) interact with the functional groups present on the enzyme surface and often reduce or completely destroy the catalytic activity of the enzyme.

(iv) Activity of certain enzymes depends upon certain non-protein substances called co-enzymes. For each enzyme, there is only one co-enzymes.

(v) Enzymes loose their activity when exposed to UV radiation or in presence of electrolyte.

(vi) The effect of pH on the rate of enzyme catalyzed reaction is of complex nature. Usually, the rate possess through a maximum as the PH increased. (PH 5-7)

(vii) Even a small amount of an enzyme can be highly efficient in bringing about a particular biological reaction.

(viii) Enzyme does not disturb the final state of equilibrium.

8. Write short notes on the following-

(a) Promoters (b) Negative catalysis (c) Catalytic poisons (d) Autocatalysis

Ans. (a) Promoters:

The addition of a small amount of foreign substances, which are not themselves catalytically active, sometimes increases the catalytic activity of the catalyst. Such substances which catalyze the catalyst are called **promoters**.

Examples: In the manufacture of ammonia by Haber's Process, finely divided Fe acts as a catalyst while Molybdenum (or a mixture of alumina, Al_2O_3 and K_2O) acts as a promoter.

(b) **Negative catalysis:** The substances which decrease the rate of a chemical reaction are called Negative Catalyst.

(c) **Ex:** alcohol retards the oxidation of chloroform to poisonous phosgene

(c) **Catalytic poisons:** The activity of a catalyst is inhibited or completely destroyed by the presence of even minute traces of certain substances, called catalytic poison or anti-catalyst.

Example: In the manufacture of H_2SO_4 by contact process, a trace of As_2O_3 destroys the catalytic activity and efficiency of spongy Platinum.

(d) **Autocatalysis:** When a product formed during the reaction enhances the velocity of the reaction (or acts as a catalyst), the phenomenon is called autocatalysis. In other words, if one of the products of a reaction is capable of catalyzing the same reaction in which it is produced this is called autocatalysis.

Examples: when an oxalate reacts with acidified KMnO_4 solution, the Mn (II) ions (resulting from the reduction of permanganate) catalyze the reaction.

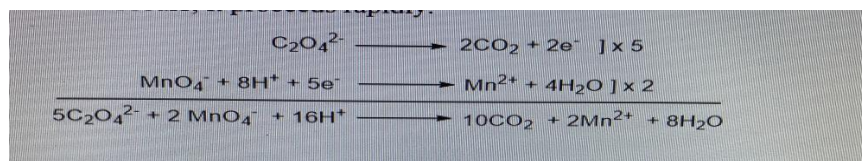

9. Write down the catalyst and reaction conditions necessary for the following industrial process.

(a) Bosch Process (b) Haber's process (c) Contact process (d) Ostwald process (e) Bergius Process

Ans 9.

Sl No	Process	Catalyst	Temp	Reaction	Remarks
a	Bosch's Process	Fe ₂ O ₃	400-450 ⁰ C	(CO+H ₂)+H ₂ O-> CO ₂ +2H ₂	It is used for the manufacture of H ₂ . Cr ₂ O ₃ is used as promoter.
b	Haber's Process	Fe	450 ⁰ C	N ₂ +3H ₂ ->2NH ₃	It is used for the manufacture of ammonia; Al ₂ O ₃ + K ₂ O or Mo is also used as Promoters
c	Contact Process	V ₂ O ₅ or Platinised asbestos	450 ⁰ C	2SO ₂ +O ₂ ->2SO ₃	It is used for the manufacture of sulfuric acid
d	Ostwald Process	Platinised Asbestos	300 ⁰ C	4NH ₃ +5O ₂ ->4NO+6H ₂ O; 2NO+O ₂ -> 2NO ₂ 4NO ₂ +2H ₂ O+O ₂ -> 4HNO ₃	Excess of air(as promoter) is also required.
e	Bergius Process	Tin or Nickel oleate	450 ⁰ C	Coal->Gasoline	Heavy oil is also required for making paste of coal with catalyst.

10. Explain why rough surface of a catalyst is more effective than smooth surface. .

Ans 10. A rough surface of a catalyst is more effective for several reasons:

1. **Increased Surface Area:** Roughness increases the surface area of the catalyst, providing more active sites for chemical reactions to occur. This allows for a greater number of reactant molecules to come into contact with the catalyst, leading to higher reaction rates.

2. **Enhanced Adsorption:** Rough surfaces can adsorb reactant molecules more effectively due to their irregularities. This improves the chances of reactants binding to the catalyst, which is a crucial step in many catalytic reactions.

3. **Catalytic Sites:** Irregularities in the surface structure can create diverse catalytic sites with varying reactivity. This can enable the catalyst to participate in a wider range of reactions or accommodate molecules of different sizes and shapes.

Overall, the increased surface area and improved adsorption properties of a rough catalyst surface make it more effective in promoting chemical reactions

11. Write down the mechanism of hydrogenation reactions using Wilkinson Catalyst

Ans. Hydrogenation reaction by Wilkinson's Catalyst: $(PPh_3)_3RhCl$

Tris-triphenyl phosphine Rhodium Chloride, $(PPh_3)_3RhCl$ which is generally known as Wilkinson's Catalyst acts as a homogenous catalyst for the hydrogenation of alkenes and alkynes. The catalyst is notable to reduce other functional groups although it is a very reactive compound. The mechanism of the reaction given below:

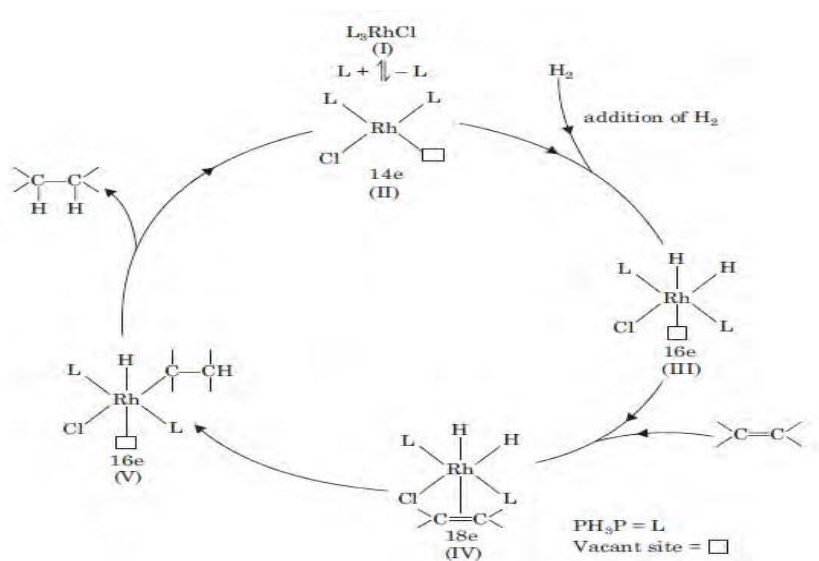

12. Why does the reaction rate of an enzyme-catalyzed reaction changes from 1st order to zero order as the substrate concentration is increased?

Ans: Each enzyme molecule has one or more 'active' sites at which the substrate must be bound in order that the catalytic action may occur. At low substrate concentration, most of these active sites are unoccupied at any time. As the substrate concentration is increased, the number of active sites which are occupied increases and hence the reaction rate also increases. However, at very high substrate concentration, virtually all the active sites are occupied at any time so that further increase in substrate concentration cannot further increase the formation of enzyme-substrate complex.

13. What is the significance of Lineweaver-Burk plot.

Ans 13. Lineweaver-Burk plots provide a graphical representation of the Michaelis-Menten equation and offer a convenient way to analyze enzyme kinetics data. These plots are a graphical representation of enzyme kinetics, specifically the Michaelis-Menten equation. By plotting the

reciprocal of the initial reaction velocity against the reciprocal of the substrate concentration, we can determine important kinetic parameters.

The Lineweaver-Burk plot allows us to determine the V_{max} and K_m values of an enzyme. V_{max} represents the maximum velocity of the reaction, while K_m represents the substrate concentration at which the reaction velocity is half of V_{max} . These parameters provide valuable insights into the enzyme's efficiency and affinity for its substrate.

These plots are obtained by plotting the inverse of the reaction rate against the inverse of the substrate concentration. By doing so, a straight line is obtained, which can be used to determine important kinetic parameters.

$$\frac{1}{\text{Rate } (r)} = \frac{K_m + [S]}{V_m [S]} = \frac{K_m}{V_{max} [S]} + \frac{1}{V_{max}}$$

A plot of $1/\text{Rate}(r)$ against $1/[S]$ gives a straight line whose intercept on the x-axis and y-axis are $(-1/K_m)$ and $1/V_{max}$, respectively and slope is (K_m/V_{max}) , as shown in the Fig. below.

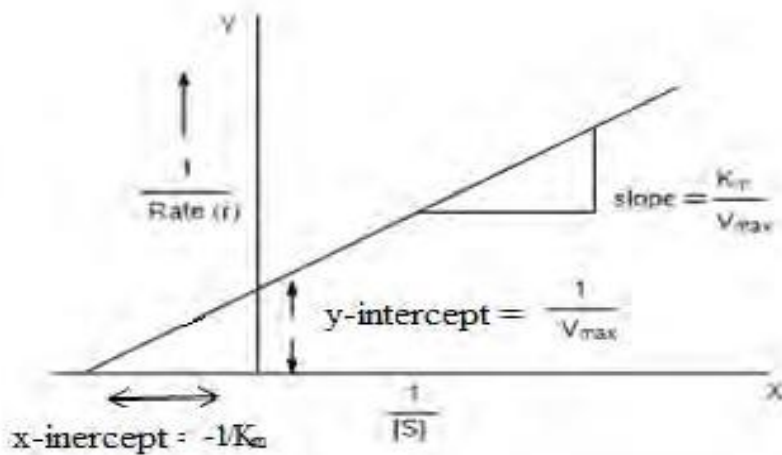

Fig. A plot of $1/r$ vs $1/[S]$ i.e. Lineweaver-Burk plot

Q14. Define K_m and give its significance.

Ans 14. K_m is defined as the substrate concentration at which the reaction rate is half of the maximum reaction velocity (V_{max}).

A lower K_m value indicates a higher affinity between the enzyme and its substrate. This means that the enzyme can effectively bind to the substrate even at low substrate concentrations, resulting in a faster reaction rate.

On the other hand, a higher K_m value suggests a lower affinity, indicating that the enzyme requires a higher substrate concentration to achieve the same reaction rate.

Q15. Define Phase transfer catalyst. List its advantages and disadvantages.

Ans. A phase-transfer catalyst (PTC) is a catalyst that facilitates the migration of a reactant from one phase into another phase where the reaction occurs. Phase-transfer catalysis is a special form of heterogeneous catalysis. Ionic reactants are often soluble in an aqueous phase but insoluble in an organic phase in the absence of the phase-transfer catalyst. The catalyst functions like a detergent for solubilizing the salts into the organic phase.

Examples of Phase-transfer catalysts:

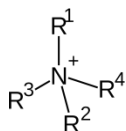

X^-

and

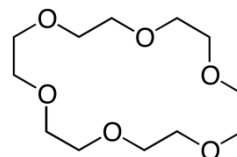

Quaternary ammonium salts(Q^+X^-)

Crown ether

Advantages: By using a PTC process,

- One can achieve faster reactions,
- Make fewer byproducts,
- eliminate the need for expensive or dangerous organic solvents that will dissolve all the reactants in one phase,
- eliminatetheneedforexpensiverawmaterialsand/orminimizewasteproblems.

Disadvantages:

- Sometimes difficult in separation of product from Catalyst
- Rapid decomposition of some of the most commonly used PTC

Q16. Give the Mechanism of Quaternary Ammonium Salts as Phase-Transfer Catalyst.

Ans 16.

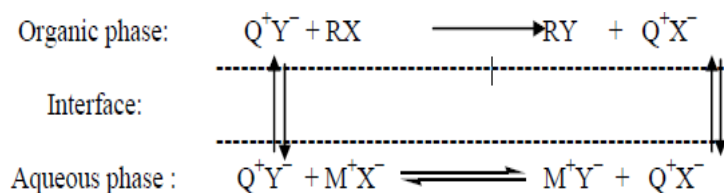

An overview of PTC reactions is given in the scheme above:

The ion pair (Q^+Y^-) is generated in aqueous phase by reaction between salt of alkali metal M^+Y^- and catalyst Quaternary ammonium salts (Q^+X^-). Owing to the oleophilic character of Q^+ , the anion Y^- is extracted into the organic phase across the interface. Here the necessary contact with alkyl halide is established and displacement reaction takes place. The displaced anion X^- is transferred back into aqueous phase in the form of an ion pair Q^+X^- and the cycle is completed.

1. Which of the following facts about catalysts is incorrect?

- Catalysts reduce a reaction's activation energy.
- Catalysts increase the number of reactions that can happen spontaneously
- Catalysts enhance the number of molecules with enough energy to break beyond the activation energy barrier.
- Catalysts offer a different technique to get from reactant to product.

Answer: (b) Catalysts increase the number of reactions that can happen spontaneously because Catalysts improve the rate of reaction by giving a lower-activation-energy alternative reaction

pathway. Catalysts, on the other hand, have no effect on things like enthalpy, entropy, or the spontaneity of a reaction.

on the other hand, have no effect on things like enthalpy, entropy, or the spontaneity of a reaction.

2. Which one of the following is not a catalysis category?

- a) Homogeneous
- b) Heterogeneous
- c) Artificial
- d) Enzymatic

Answer: (c) Artificial because Catalysis is divided into four categories: homogeneous, heterogeneous, auto, and enzymatic. Catalysis does not include the term "artificial."

3. The factor that influences a heterogeneous catalyst's activity is _____

- a) Total surface area only
- b) The number of active sites per unit amount of catalyst only
- c) Method of preparation, prior treatment only
- d) Total surface area, number of active sites and method of preparation

Answer: (d) Total surface area, number of active sites and method of preparation because Total surface area, number of active sites per unit amount of catalyst, technique of manufacture, and prior treatment are the elements that determine the activity of a heterogeneous catalyst.

4. Which of the following does not happen at the phase transition?

- a) Crystallization
- b) Heterogeneous catalysis
- c) Homogeneous catalysis
- d) Corrosion

Answer: (c) Homogeneous catalysis because a catalyst is a substance that boosts the rate of a reaction but does not change chemically during the process. The reactants and catalyst are in the same phase in homogeneous catalysis (i.e., liquid or gas).

5. The activity of the catalyst is reduced by the promoter.

a) True

b) False

Answer: (b) False because a catalytic promoter is a chemical that boosts the activity of a catalyst without actually acting as one.

6. Which of the statements below is incorrect?

a) The surface area of a solid catalyst determines its efficiency.

b) Catalysts work by giving an alternative path for the reaction that has a lower activation energy.

c) Catalyst reduces the energy required to activate the forward reaction while having no effect on the energy required to activate the backward reaction.

d) The overall enthalpy change of the reaction is unaffected by the catalyst.

Answer: (c) Catalyst reduces the energy required to activate the forward reaction while having no effect on the energy required to activate the backward reaction because a catalyst creates a lower-activation-energy alternative pathway for the reaction. When the activation energy is low, more reactant particles have adequate energy to react, resulting in a faster reaction.

7. Which of the following is a poison that catalyzes a reaction?

a) Potassium nitrate

b) Aluminum nitrate

c) Aluminum oxide

d) Chlorine

Answer: (c) Aluminum oxide because Aluminum oxide is well-known for its sophisticated qualities, and it is mostly used to prevent corrosion. It absorbs moisture and has a high retentivity, making it an excellent catalytic poison.

8. As a catalytic promoter, which of the following is used??

- a) Chlorine
- b) Nitrate
- c) Bromine
- d) Helium

Answer: (b) Nitrate.

9. For the following reaction, which of the following is utilized as a catalyst?

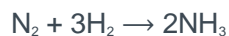

- a) Zinc
- b) Chlorine
- c) Platinum
- d) Water

Answer: (c) Platinum

10. When a catalyst is used in a reaction, which of the following changes?

- a) Heat of reaction
- b) Product of reaction
- c) Equilibrium constant
- d) Activation energy

Answer: (d) Activation energy because when a catalyst is utilised in a reaction, the activation energy changes.

11. Which of the following is incorrect for enzymes?

- (a) Enzymes are specific

- (b) Most of the enzymes are protein
- (c) Reactivity of enzymes is least at optimum temperature
- (d) High temperature and UV rays can denature enzymes

Answer: (c)

12. The rate determining step of Michaelis-Menten kinetics is _____

- a) The complex dissociation step to produce products
- b) The complex formation step
- c) The product formation step
- d) None of the mentioned

Answer: a

Explanation: The breakdown of ES complex is the rate determining step of Michaelis-Menten kinetics.

13. The molecule which acts directly on an enzyme to lower its catalytic rate is _____

- a) Repressor
- b) Inhibitor
- c) Modulator
- d) Regulator

Answer: b

Explanation: An inhibitor is a substance that interferes with the substrate-active site binding and slows down the catalytic rate.

Q3 An enzyme hydrolyzed a substrate concentration of 0.03 mmol/L, the initial velocity was 1.5×10^{-3} mmol/L.min⁻¹ and the maximum velocity was 4.5×10^{-3} mmol/L.min⁻¹. Calculate the K_m value.

$$V_0 = \frac{V_{\max} [S]}{K_m + [S]}$$

$$1.5 \times 10^{-3} = \frac{4.5 \times 10^{-3} * 0.03}{K_m + 0.03}$$

$$K_m + 0.03 = \frac{4.5 \times 10^{-3} * 0.03}{1.5 \times 10^{-3}}$$

$$K_m + 0.03 = 0.135 \times 10^{-3} / 1.5 \times 10^{-3}$$

$$K_m + 0.03 = 0.09$$

$$K_m = 0.06$$

$$S_1 = 0.03$$

$$V_{01} = 1.5 \times 10^{-3}$$

$$V_{\max} = 4.5 \times 10^{-3}$$

$$K_m = ?$$

Q2 An enzyme with a K_m of 0.06 mmol/L hydrolyzed a substrate of a concentration 0.03 mmol/L. The initial velocity of the reaction was 0.0015 mmol/L.min⁻¹. Calculate the substrate concentration which gives an initial velocity of 0.003 mmol/L.min⁻¹.

Solution

$$V_0 = \frac{V_{\max} [S]}{K_m + [S]}$$

$$1.5 \times 10^{-3} = \frac{V_{\max} * 0.03}{0.06 + 0.03}$$

$$3 \times 10^{-3} = \frac{4.5 \times 10^{-3} * S_2}{0.06 + S_2}$$

$$V_{\max} = 1.5 \times 10^{-3} * 3 = 4.5 \times 10^{-3}$$

$$S_2 = 0.12 \text{ mmol/L}$$

$$S_1 = 0.03$$

$$K_m = 0.06$$

$$V_{01} = 1.5 \times 10^{-3}$$

$$V_{02} = 3 \times 10^{-3}$$

$$S_2 = ?$$

Tutorial Sheet

Module-IV:

Spectroscopic Techniques (8 Lectures) Absorption Spectroscopy, Lambert-Beers law, Principles and applications of UV-Visible spectroscopy, Principles and applications of Vibrational spectroscopy; Introduction of NMR spectroscopy

Q. 1: State the terms involved in Lambert's Beer Law.

Ans. **Lambert – Beer's law**

Lambert's law stated that absorbance of a material sample is directly proportional to its thickness (path length). Much later, **Beer's law** stated that absorbance is proportional to the concentrations of the attenuating species in the material sample.

Combination of these two laws resulted in Lambert – beer's law, which states that absorbance of a monochromatic light passing through a medium is proportional to both thickness(l) of the medium as well as the concentration (c) of the absorbing species.

Mathematically,

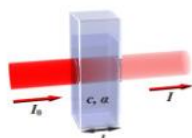
$$\log_{10} \frac{I_0}{I} = A = \epsilon lc$$

- I_0 = Intensity of incident light
- I = Intensity of transmitted light
- ϵ = molar extinction coefficient
- l = path length of cell
- c = concentration of sample

Q. 2: Show following electronic transitions between the MOs in an organic molecule.

$\sigma \rightarrow \sigma^*$ (C-C) $\pi \rightarrow \pi^*$ (C=C) $\pi \rightarrow \pi^*$ (C=O) $n \rightarrow \pi^*$ (C=O) $\pi_2 \rightarrow \pi_3^*$ (C=C-C=C)

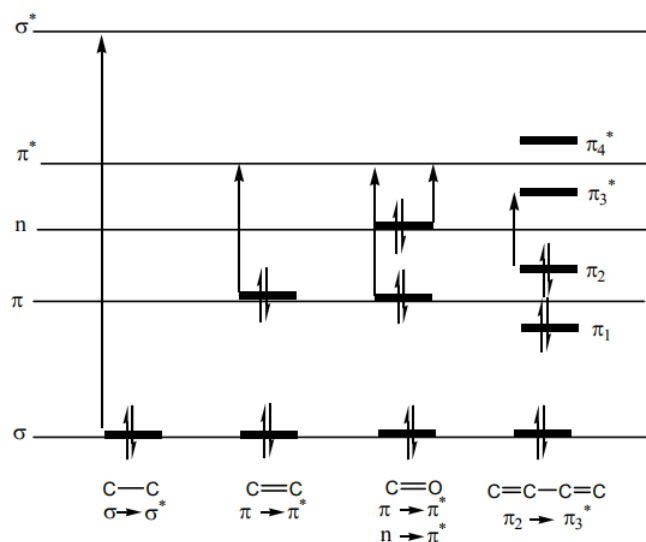

Q. 3: Instead of a single electronic transition, absorption spectrum is broad - explain.

Ans: If the differences between electronic energy levels of two electronic states are well defined i.e. if the nuclei of the two atoms of a diatomic molecule are held in fixed position, the peaks accordingly should be sharp. However, vibrations and rotations of nuclei occur constantly and as a result each electronic state in a molecule is associated with a large number of vibrational and rotational states. At room temperature, the molecules in the ground state will be in the zero vibrational level (G_{v_0}). This is shown schematically in figure below.

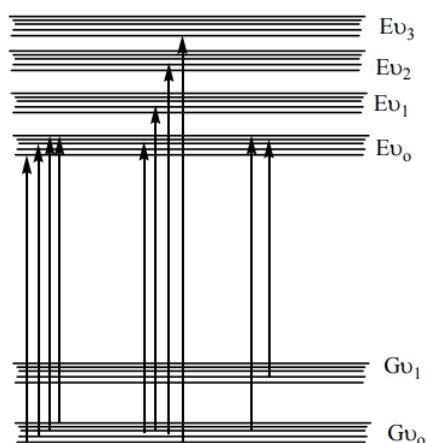

Figure : Energy level diagram showing excitation between different vibrational and rotational levels of two electronic states

The transition of an electron from one energy level to another is thus accompanied by simultaneous change in vibrational and rotational states and causes transitions between various vibrational and rotational levels of lower and higher energy electronic states. Therefore many radiations of closely placed frequencies are absorbed and a broad absorption band is obtained.

Q.4: $n \rightarrow \pi^*$ Transition in acetone is red shifted on changing the solvent from water to hexane - explain.

In case of $n \rightarrow \pi^*$ transitions, the polar solvents form hydrogen bonds with the ground state of polar molecules more readily than with their excited states. Therefore, in polar solvents the energies of electronic transitions are increased. For example, the figure 9 shows that the absorption maximum of acetone in hexane appears at 279 nm which in water is shifted to 264 nm, with a blue shift of 15nm.

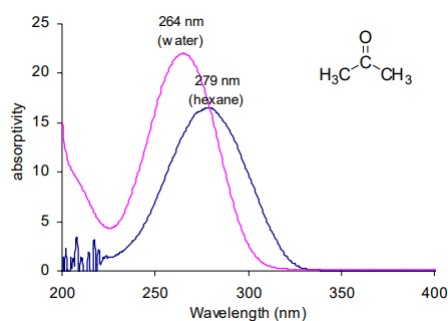

Figure : UV-spectra of acetone in hexane and in water

Q. 5: Define and give example: Chromophore, Auxochrome

Chromophore: The energy of radiation being absorbed during excitation of electrons from ground state to excited state primarily depends on the nuclei that hold the electrons together in a bond. The group of atoms containing electrons responsible for the absorption is called chromophore. Most of the simple un-conjugated chromophores give rise to high energy transitions of little use.

For example, alkanes contain only single bonds with only possible $\sigma \rightarrow \sigma^*$ type electronic transitions. These transitions absorb radiations shorter than wavelengths that are experimentally accessible in usually available spectrophotometers. In saturated molecules with heteroatom bearing non-bonding pairs of electrons, $n \rightarrow \sigma^*$ transitions become available. These are also high energy transitions. In unsaturated compounds, $\pi \rightarrow \pi^*$ transitions become possible. Alkenes and alkynes absorb ~ 170 nm but the presence of substituents significantly affects their position. The carbonyl compounds and imines can also undergo $n \rightarrow \pi^*$ transitions in addition to $\pi \rightarrow \pi^*$. Amongst these, the most studied transitions are $n \rightarrow \pi^*$ as these absorb at relatively longer wavelength 280-300 nm. These are low intensity (ϵ 10 -100) transitions.

Auxochrome: The substituents that themselves do not absorb ultraviolet radiations but their presence shifts the absorption maximum to longer wavelength are called auxochromes. The substituents like methyl, hydroxyl, alkoxy, halogen, amino group etc. are some examples of auxochromes.

Q. 6: Explain the terms: Bathochromic Shift, Hypsochromic Shift, Hypochromic Effect, Hyperchromic Effect

Ans: (i) Bathochromic Shift or Red shift: A shift of an absorption maximum towards longer wavelength or lower energy.

(ii) Hypsochromic Shift or Blue Shift: A shift of an absorption maximum towards shorter wavelength or higher energy.

(iii) Hypochromic Effect: An effect that results in decreased absorption intensity.

(iv) Hyperchromic Effect: An effect that results in increased absorption intensity.

Q. 7: Explain in the difference in the absorption spectra of ethylene and buta diene.

Ans: The presence of conjugate double bond decreases the energy difference between HOMO and LUMO of resulting diene. The figure 10 shows the change in energy of MO on conjugation. As a result, the radiations of longer wavelength are absorbed. The conjugation not only results in bathochromic shift (longer wavelength) but also increases the intensity of

absorption. As the number of conjugated double bonds is increased, the gap between highest occupied molecular orbital (HOMO) and lowest unoccupied molecular orbital (LUMO) is progressively lowered. Therefore, the increase in size of the conjugated system gradually shifts the absorption maximum (λ_{max}) to longer wavelength and also increases the absorption. For example, ethylene absorbs at 175 nm ($\epsilon = 1000$) and the conjugation in butadiene gives a strong absorption at longer wavelength at 230 nm and with higher intensity ($\epsilon = >1000$).

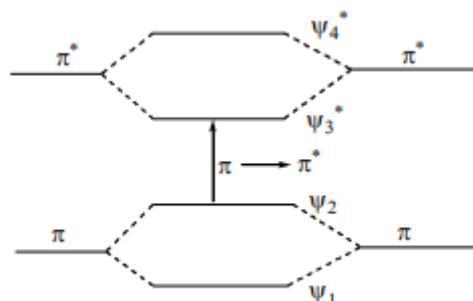

Figure : Effect of conjugation on orbitals' energy and respective π - π^* transition

Q. 8: Discuss the effect of electron donating and electron withdrawing groups on the secondary bands of aromatic compounds.

Ans: Effect of Electron-withdrawing and Electron-releasing Groups: Electron-withdrawing substituents viz. NH_3^+ , SO_2NH_2 , CN, COOH, COCH_3 , CHO and NO_2 etc. have no effect on the position of secondary absorption band of benzene ring. But their conjugation effects with π electrons of the aromatic ring are observed. Electron-donating groups such as - CH_3 , -Cl, -Br, -OH, - OCH_3 , - NH_2 etc increase both λ_{max} and ϵ_{max} values of the secondary band.

In case of disubstituted benzene derivatives, it is essential to consider the effect of both the substituents. In para-substituted benzenes, two possibilities exist. If both the groups are electron-donating then the observed spectrum is closer to monosubstituted benzene. The group with stronger effect determines the extent of shifting of primary band. If one group is electron-releasing and other is electron-withdrawing, the magnitude of red shift is greater compared to the effect of single substituent individually. This is attributed to the increased electron drift from electron-donating group to the electron-withdrawing group through π -bond of benzene ring. For example, aniline shows secondary band at 285 nm which due to presence of electron-withdrawing p-nitro substituent is shifted to 367 nm with a significant increase in absorptivity (figure 1).

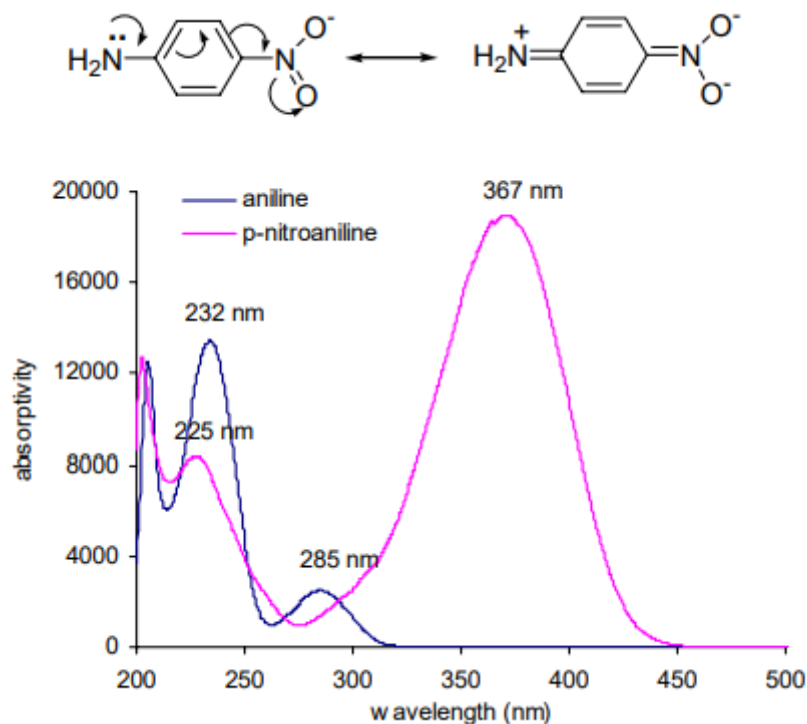

Figure 1: UV-spectra of aniline and p-nitroaniline in methanol

Q. What is the necessary condition for IR spectroscopy?

Answer – According to the selection rule for IR transitions, the change in the electric dipole moment of the functional group present in a molecule or sample during the vibration is required for a molecule or sample to show an infrared spectrum.

The **activity or inactivity of a vibrational mode in the infrared spectrum is determined by the change in the dipole moment** of a molecule during the vibration. This principle is often referred to as the "selection rule" for infrared (IR) spectroscopy.

IR Active: A mode of vibration is **IR active if it leads to changes in the dipole moment of the molecule**. This change in dipole moment allows the vibrational mode to interact with the electric field of the infrared light, which leads to absorption of the IR radiation. As a result, the vibration becomes detectable in the IR spectrum. An example can be the C=O stretching vibration in carbonyl compounds which is IR active due to the polarity of the C=O bond.

IR Inactive: If a vibration **doesn't cause a change in the dipole moment of a molecule**, it's IR inactive. This means that these vibrational modes won't be seen in the IR spectrum. For example, symmetric stretch of a nonpolar molecule like O₂ or N₂ is IR inactive because the vibration does not change the dipole moment.

Q. What do you mean by 'fingerprint region' of IR absorption spectrum of an organic molecule?

What is functional groups region?

Answer:

An infrared spectrum of an organic compound comprises many bands and assigning each band to a particular mode of vibration is practically impossible but two non-identical molecules generally have different IR spectra. An IR spectrum, therefore, is a fingerprint of the molecule. The region most useful for the purpose of "fingerprinting" of the compound is $650\text{-}1350\text{ cm}^{-1}$. This region comprises a large number of bands due to skeletal vibrations and when the spectrum we are studying coincides exactly with the spectrum of a known compound, it can be safely assumed that the two compounds are identical.

The region above 1350 cm^{-1} often provides easily recognizable bands of various functional groups and thus much valuable structural evidence from relatively few of these bands is obtained and total interpretation of the complete spectrum is seldom required. The region is called functional groups region.

Q. For the following molecule, indicate which mode is IR active and which is inactive.

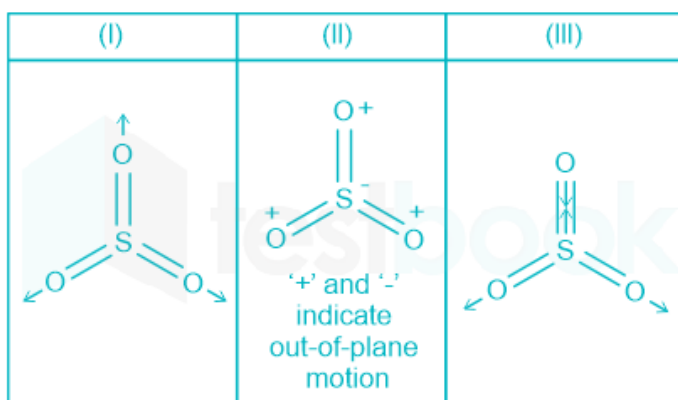

Answer :

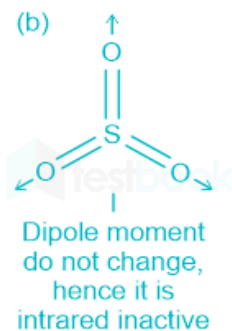

The dipole moment will no change so this will be IR inactive

For II

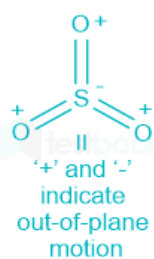

For III

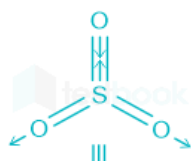

Q. Is carbon dioxide IR inactive?

Answer : Since carbon dioxide is linear molecule it has $3n-5=4$ vibrations and they are pictured below.

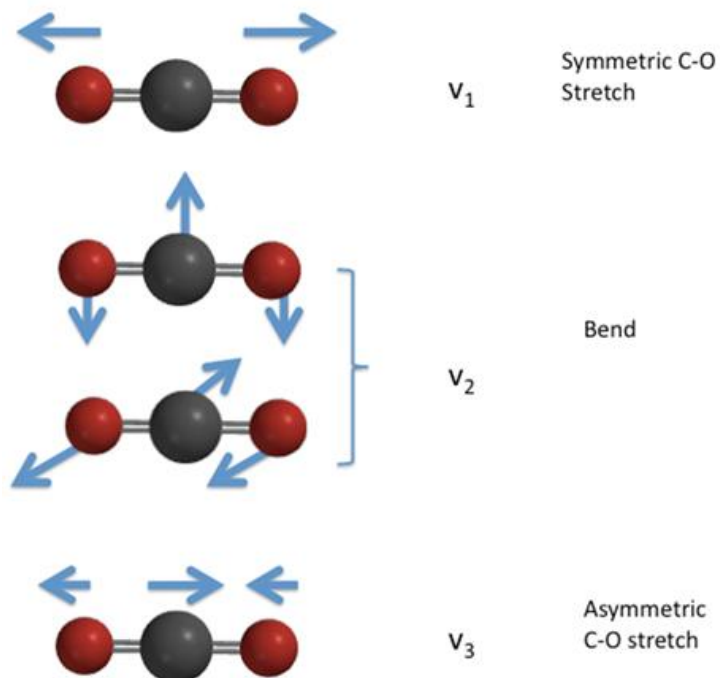

- The symmetric stretch does not result in a change (of the initially zero dipole moment), so it is IR inactive.
- The asymmetric stretch does result in a change in dipole moment so it is IR active.
- The bend also results in a change in dipole moment so it too is IR active.

Q. How many vibrational modes are there in the CH₄ molecule ?

Answer:

The degrees of vibrational modes for **linear molecules** can be calculated using the formula:

$$3N-5 \quad (1)$$

The degrees of freedom for **nonlinear molecules** can be calculated using the formula:

$$3N-6 \quad (2)$$

N is equal to the number of atoms within the molecule of interest.

CH₄: Nonlinear molecule, vibrational modes = $3N-6 = 15-6 = 9$

Q. Discuss 'ring size effect' in carbonyl compounds.

Answer:

Ring Size Effects: Six-membered rings with carbonyl group e.g. cyclohexanone absorb at normal value i.e. 1715 cm^{-1} . Decrease in ring size increases the C=O stretching frequency. Smaller rings require the use of more p-character to make C-C bonds for the requisite small angles. This gives more s character to the C=O sigma bond and thus results in strengthening of C=O double bond. The comparison of C=O stretching frequencies of various compounds in figure 15 shows that in ketones and esters, $\sim 30 \text{ cm}^{-1}$ increase in frequency occurs on moving to one carbon lower ring.

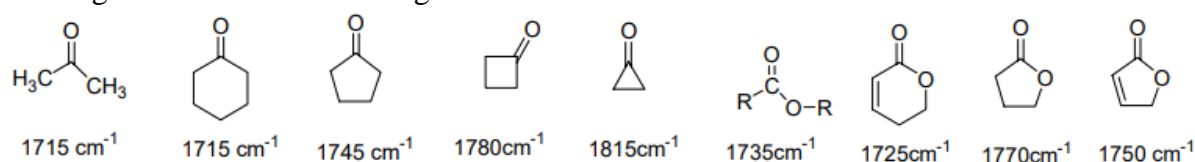

Fig: C=O stretching frequencies in various compounds

Q. Show the NMR Spectrum of some simple molecule

- 1,1,2-Trichloroethane
- 2-Chloropropanoic acid
- 1-Nitropropane

Answer:

- 1,1,2-Trichloroethane
No of equivalent protons =2

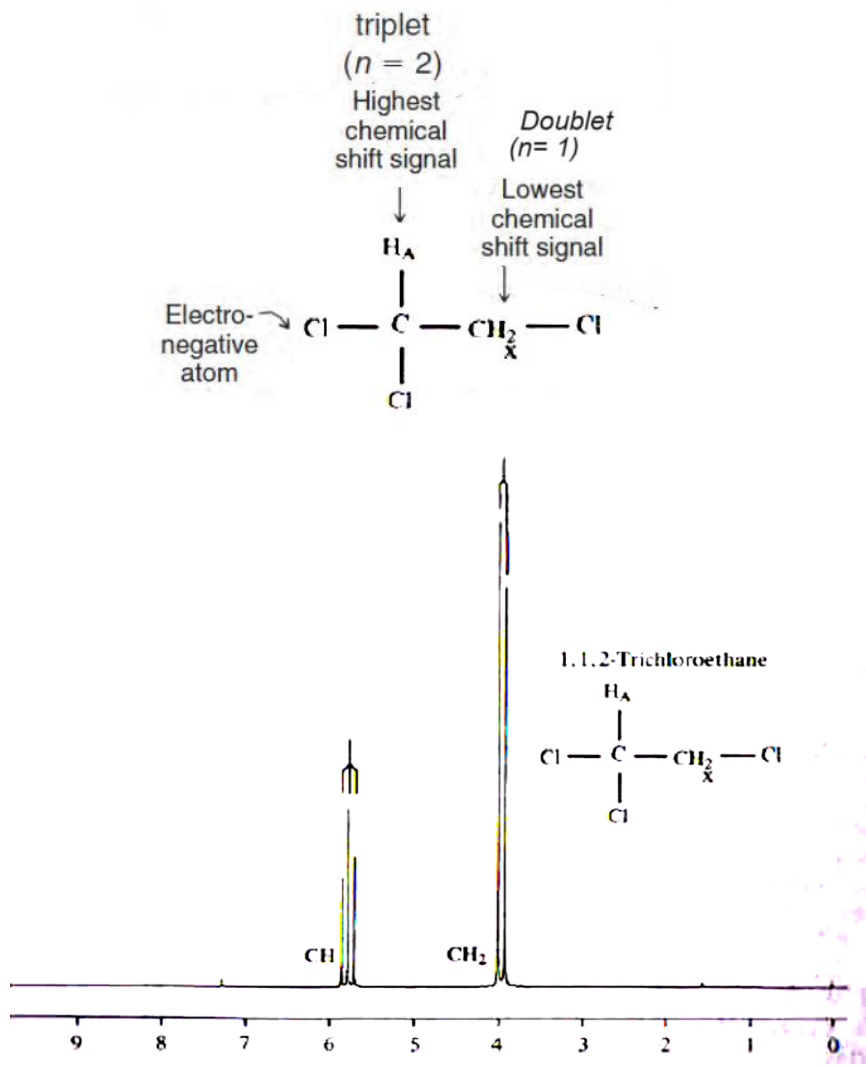

b) 2-Chloropropanoic acid
Types of proton = 3

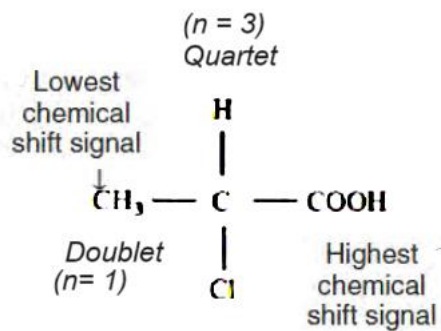

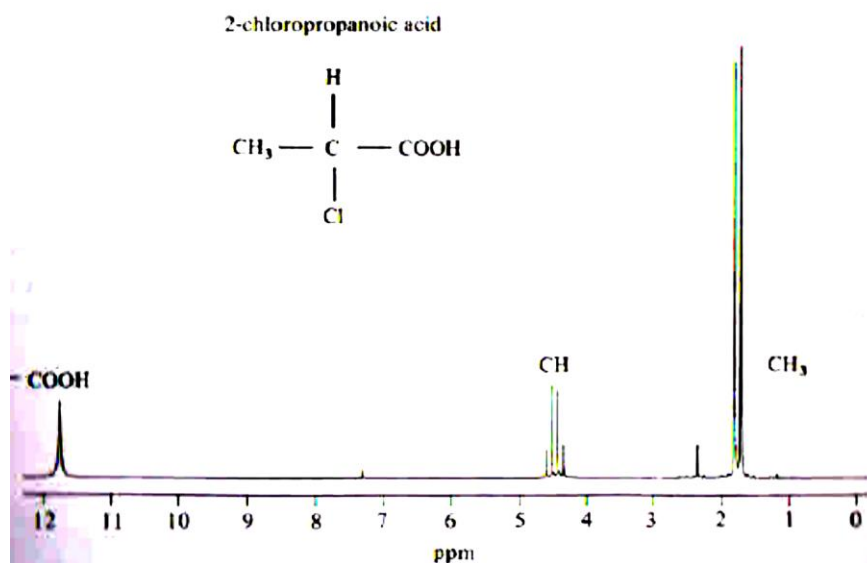

a) 1-Nitropropane

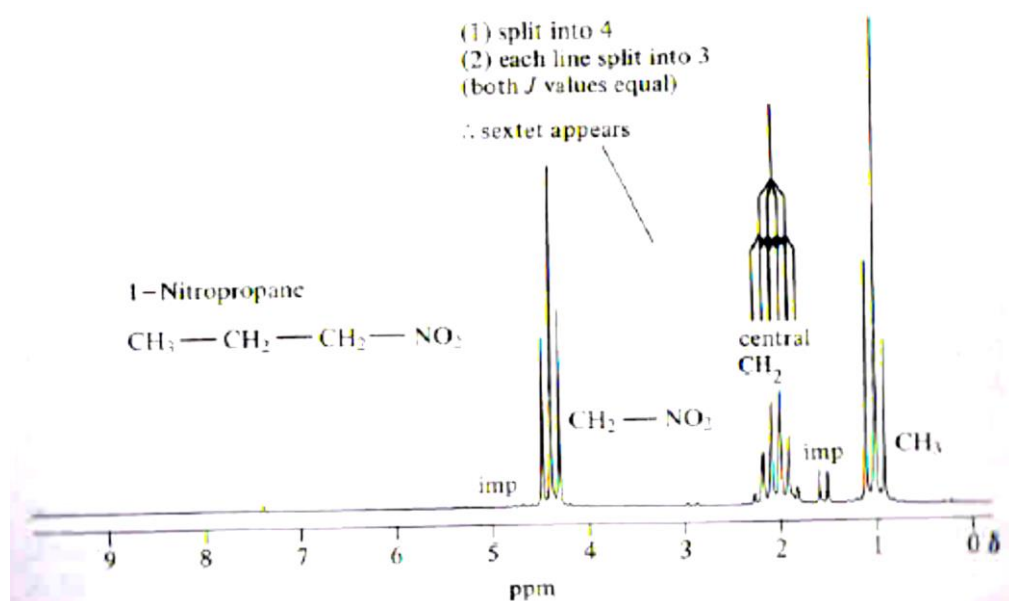

Q. Name the two common types of NMR spectroscopy are used to characterize organic structure. Why weak spectrum is observed for ^{13}C NMR?

Answer

- ^1H NMR is used to determine the type and number of H atoms in a molecule; and
- ^{13}C NMR is used to determine the type of carbon atoms in a molecule.

The magnetic moment of heavy ^{13}C nucleus is $1/4^{\text{th}}$ of ^1H nucleus and natural abundance of ^{13}C is only 1.1 percent with respect to almost 100 % for ^1H nucleus. So, weak spectrum is observed for ^{13}C .

Phase Rule: Questions

1. Define Phase, Component and Degree of freedom.

Phase: **Phase** is defined as any homogenous and uniform in composition, physical distinct portions of matter, which is mechanically separated from other such parts of the system by definite boundary surfaces.

Component: **Component** is defined as the smallest number of independent variable constituents, in terms of which the composition of each phase can be expressed in the form of chemical equation.

Degree of freedom is defined as the minimum number of independently variable factors, such as pressure temperature and composition (concentration or volume), which can completely define the equilibrium of a system. The least number of variable factors (concentration, pressure & temperature) which must be specified so that the remaining variables are fixed automatically and the system is completely defined.

2. What is the number of phases in a mixture of hydrogen and nitrogen gases.

Since the gaseous mixture is miscible in all proportions, it will constitute only one phase.

3. Determine the number of phases in the following system:



This system consists of three phases (i.e. two solids and one gaseous).

4. Determine the number of *Components for the solution of NaCl* in water solvent.

It is a two component system (NaCl and H₂O).

5. Define the Phase rule.

Phase rule can be stated as, in heterogeneous systems, if equilibrium between phases are not influenced by gravity, magnetic & electrical forces, but are influenced only by pressure, temperature and concentration, then the number of degree of freedom (F) of the system is related to number of components (C) and number of phases (P) by the following phase rule equation:

$$F = C - P + 2$$

6. Consider the thermal decomposition of MgCO_3 in closed vessel:
 $\text{MgCO}_3 (\text{S}) = \text{MgO}(\text{S}) + \text{CO}_2 (\text{g})$.
 Determine the number of phases and components within this system.

This is a three phase and two component system.

Since any two of the three substances are sufficient to express the composition of each of three phases.

For example if we choose CO_2 and MgO as two component, then;

The composition of MgO phase can be expressed as $n\text{MgO}$

The composition of CO_2 phase can be expressed as $n\text{CO}_2$

The composition of MgCO_3 can be expressed as $x\text{MgO}+x\text{CO}_2$.

7. What is meant by the vapourization curve of water ? Determine the DOF within any given point within the curve.

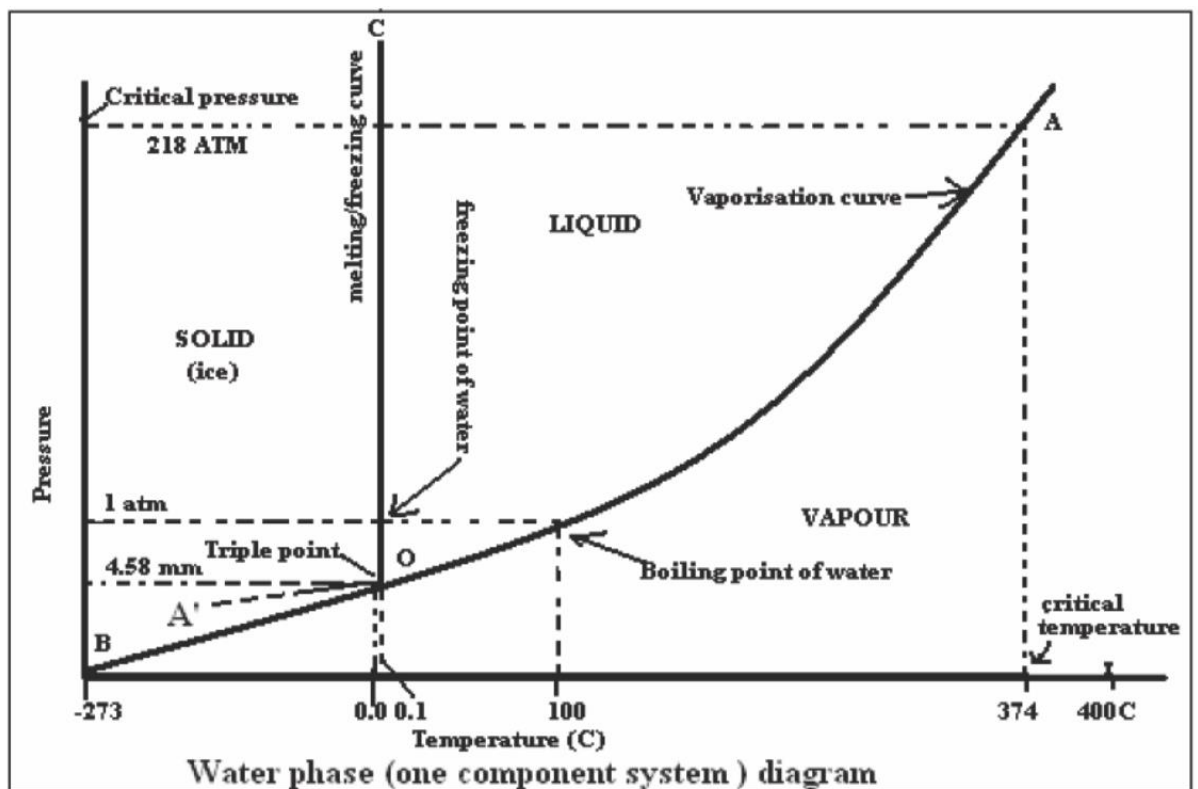

The curve OA is called the vapourization curve of water; it represents the equilibrium between liquid water and vapour. At any point on the curve the following equilibrium will exist:



The degree of freedom of the system is one, i.e., univariant. This is predicted by the phase rule ($F=C-P+2$; no. of component= $1(\text{H}_2\text{O})$; no. of phase= 2 (liquid and gas phase))
 $F=1-2+2$; $F=1$

8. What is meant by the sublimation curve of ice ? Determine the DOF within any given point within the curve.

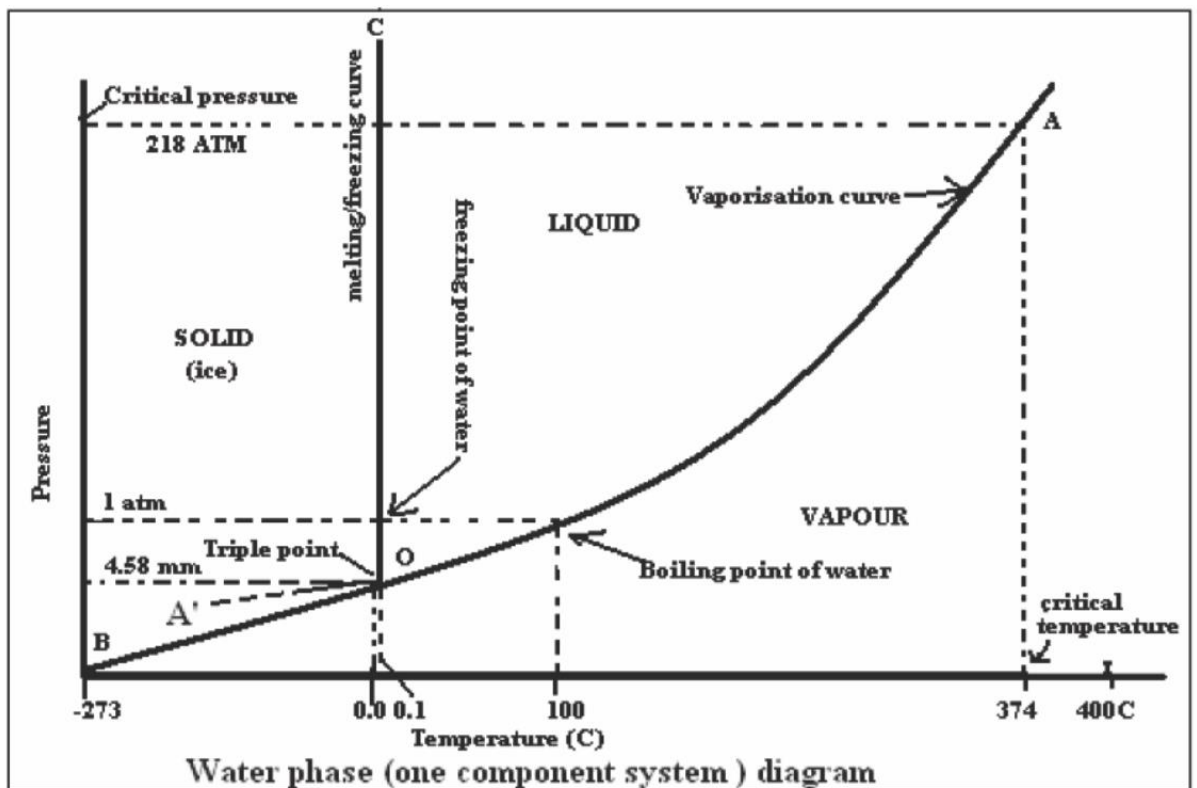

The curve OB is called the sublimation curve of ice; it represents the equilibrium between ice and vapour. At any point on the curve the following equilibrium will exist: Ice \leftrightarrow Vapour.

Using the phase rule, we get (no. of component=1(H₂O); no. of phase=2 (solid and gas phase):

$$F=C-P+2; F=1-2+2; F=1$$

Thus, The degree of freedom of the system is one.

9. What is meant by the triple point of water? Determine the DOF within this point.

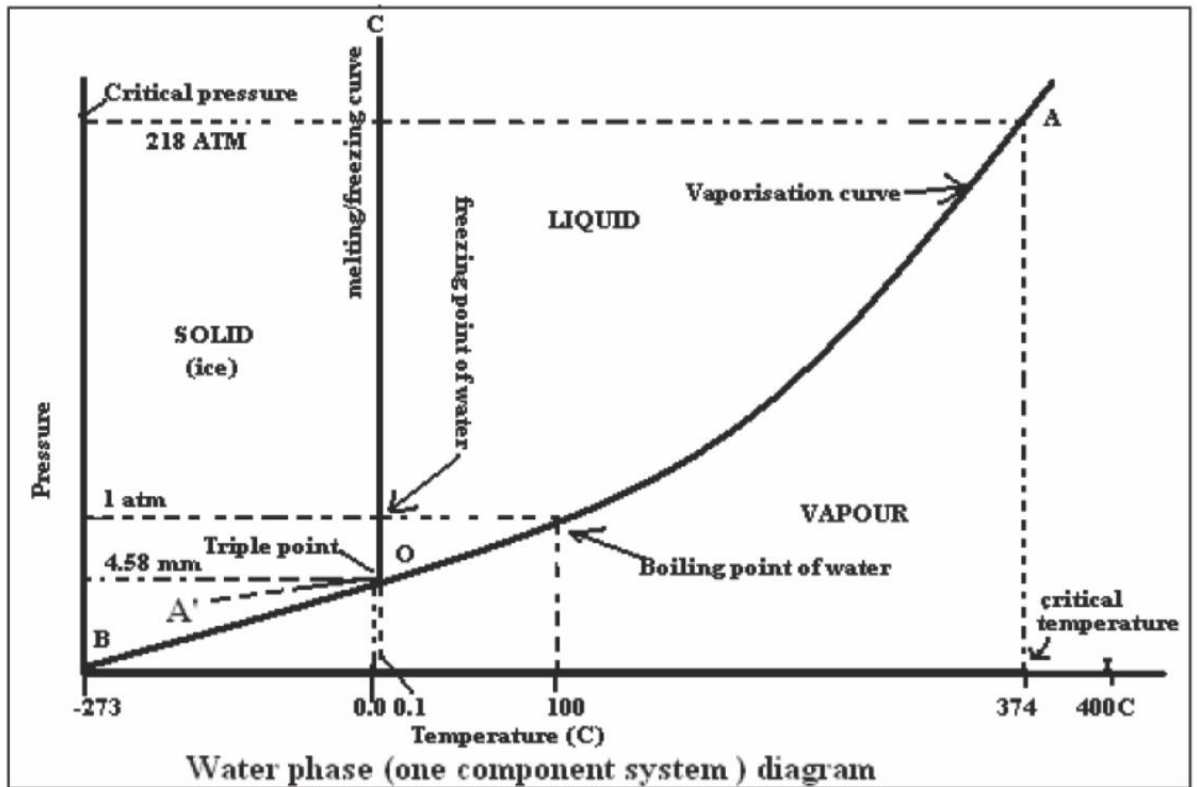

The vaporization curve (OA) and the sublimation curve (OB) meet at point O, where three phases, namely solid, liquid and vapour will coexist. Such a point is known as the “triple point”. Temperature and pressure at the triple point of water are 0.0098 OC and 4.58 mm respectively, according to phase rule, the degree of freedom is zero i.e., invariant.
 $F=C-P+2$; $F=1-3+2$; $F=0$.

10. Briefly explain why *reduced phase rule is needed to describe multi-component systems.*

In a two – component system, minimum number of phases is one, i.e., $P = 1$, according to the phase rule equation, the maximum degree of freedom is three

$$F = C - P + 2; F = 2 - 1; F = 3$$

So, the phase diagram of a binary system should be represented by a three dimensional diagram of temperatures, pressure and composition, which can not be drawn on paper. Generally solid-liquid equilibrium of an alloy has “no gas phase” and the effect of pressure is small. Therefore, experiments are conducted under atmospheric pressure. Thus, the system in which the pressure is constant (vapour phase is not considered) is known as condensed system. The phase rule becomes.

$$F' = C - P + 1$$

This is known as **reduced phase rule (or) condensed phase rule**. The phase diagram can be drawn by taking temperature and composition as the two axis. The reduced phase rule is used only when atmospheric pressure is larger than actual vapour pressure of the component.

11. What is meant by **Eutectic formation** ?

If two substances are completely miscible in the liquid state, but completely immiscible in the solid state, they form a simple eutectic mixture. Of the various mixture compositions, the one mixture (having a certain specific composition) that has the lowest melting point is known as a eutectic mixture.

12. Consider the following phase diagram for Pb-Ag mixture.

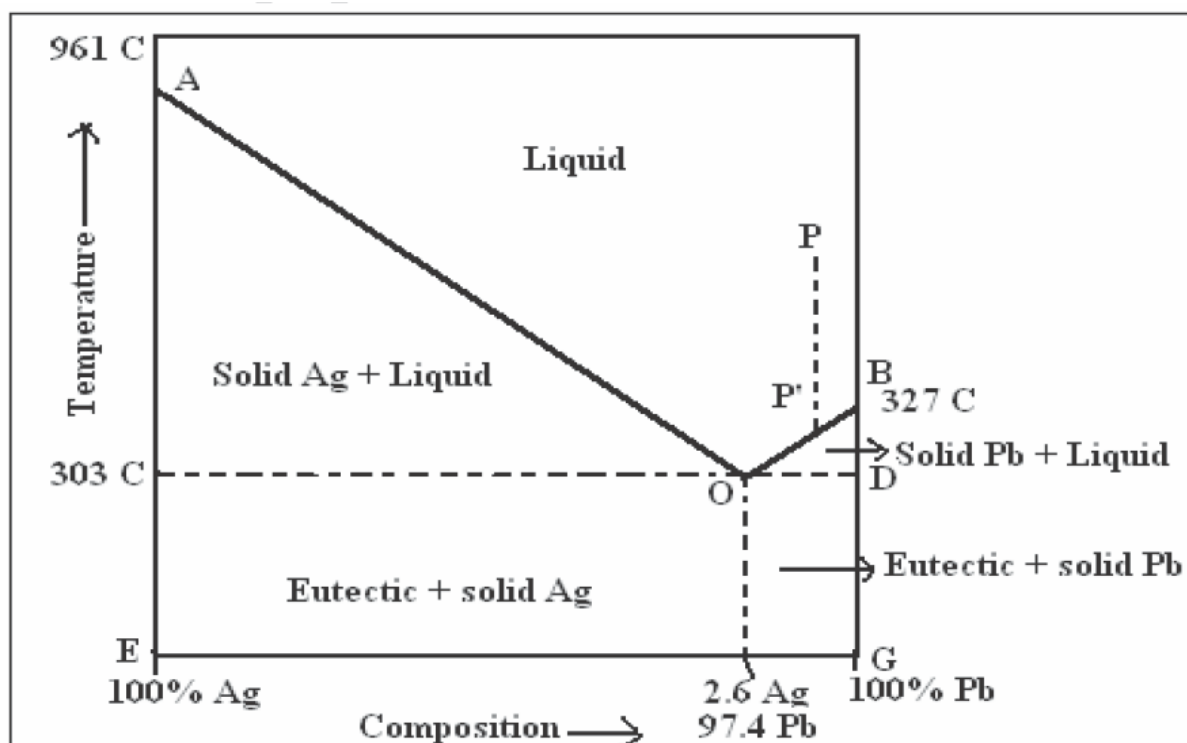

Calculate the DOF for the area AOB.

AOB region in the phase diagram consists of only one phases namely Pb-Ag solution.

According to reduced phase rule equation, we can arrive at the following (no. of component=2(Pb and Ag); no. of phase=1 (solution phase)):

$$F' = C - P + 1; F' = 2 - 1 + 1; F' = 2$$

Therefore, the system is bivariant.

13.

The reaction

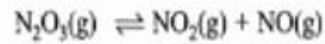

was studied at 25 °C with initial amount of N_2O_3 equal to 1.0 mol. At equilibrium, the extent of reaction is found to be 0.3 mol for a total pressure of 1 bar. Calculate K_p° the reaction.

The given reaction is

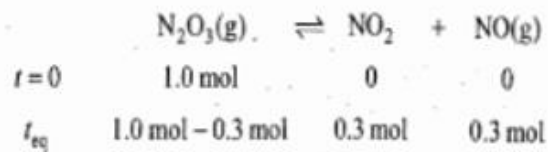

Total amount of substances at equilibrium = 1.3 mol

Now
$$p_{\text{N}_2\text{O}_3} = \frac{n_{\text{N}_2\text{O}_3}}{n_{\text{total}}} p = \frac{0.7}{1.3} (1 \text{ bar}) = 0.538 \text{ bar}$$

$$p_{\text{NO}_2} = \frac{n_{\text{NO}_2}}{n_{\text{total}}} p = \frac{0.3}{1.3} (1 \text{ bar}) = 0.238 \text{ bar}$$

$$p_{\text{NO}} = p_{\text{NO}_2} = 0.231 \text{ bar}$$

$$\begin{aligned} K_p^\circ &= \prod_B (p_B/p^\circ)^{\nu_B} = (p_{\text{NO}_2}/p^\circ)(p_{\text{NO}}/p^\circ)(p_{\text{N}_2\text{O}_3}/p^\circ)^{-1} \\ &= (0.231 \text{ bar}/1 \text{ bar})(0.231 \text{ bar}/1 \text{ bar})(0.538 \text{ bar}/1 \text{ bar})^{-1} \\ &= 0.099 \end{aligned}$$

14.

For the reaction



the equilibrium pressure at 298 K was found to be 0.67 bar. Calculate K_p° and $\Delta_r G^\circ$ of the reaction.

The given reaction is



At equilibrium

$$p_{\text{NH}_3} = p_{\text{H}_2\text{S}}$$

Since $p_{\text{NH}_3} + p_{\text{H}_2\text{S}} = 0.67$ bar, we have

$$p_{\text{NH}_3} = p_{\text{H}_2\text{S}} = \frac{0.67 \text{ bar}}{2} = 0.335 \text{ bar}$$

$$\begin{aligned} K_p^\circ &= \prod_B (p_B / p^\circ)^{\nu_B} = (p_{\text{NH}_3} / p^\circ)(p_{\text{H}_2\text{S}} / p^\circ) = (0.335 \text{ bar} / 1 \text{ bar})^2 \\ &= 0.112 \end{aligned}$$

If K_p° for $\text{H}_2(\text{g}) + \frac{1}{2} \text{S}_2(\text{g}) \rightleftharpoons \text{H}_2\text{S}(\text{g})$ is 0.80 determine the value of K_p° for

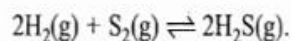

For the reaction

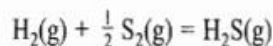

$$K_{p1}^\circ = \frac{(p_{\text{H}_2\text{S}}/p^\circ)}{(p_{\text{H}_2}/p^\circ)(p_{\text{S}_2}/p^\circ)^{1/2}} = 0.80$$

If the reaction is multiplied by 2, we have



K_p° for this reaction will be

$$K_{p2}^\circ = \frac{(p_{\text{H}_2\text{S}}/p^\circ)^2}{(p_{\text{H}_2}/p^\circ)^2 (p_{\text{S}_2}/p^\circ)} = (K_{p1}^\circ)^2 = (0.80)^2 = 0.64$$

Chemical Equilibrium Questions

1. What is chemical equilibrium? Explain with example.

Many chemical reactions proceed only to a certain extent and stop. When analysed, the resulting mixture contains both the reactants and products. It is because when reactants combine to form products, the products also start combining to give back the reactants. When such opposing processes take place at equal rates, no reaction appears to take place and it is said that a state of equilibrium has reached. A reversible reaction is said to be in the equilibrium state when the forward and backward reaction occur simultaneously at the same rate in a closed system and the concentrations of reactants and products do not change with time. In a chemical reaction, chemical equilibrium is the state in which both reactants and products are present in concentrations which have no further tendency to change with time. The chemical equilibrium is achieved when the rate of forward reaction is same as the reverse reaction.

A common example of reversible reactions of the type $\text{A} + \text{B} \rightleftharpoons \text{C} + \text{D}$

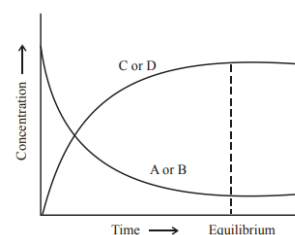
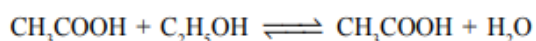

2. What are the characteristics of equilibrium state?

(i) Chemical Equilibrium is dynamic in nature. The chemical equilibrium is the result of two equal but opposite processes occurring in the forward and reverse directions and there is no “net” change occurring in the system.

(ii) Equilibrium can be attained from either side. The same state of equilibrium (characterized by its equilibrium constant which is discussed later) can be reached whether the reaction is started from the reactants or products side. For example, the same equilibrium.

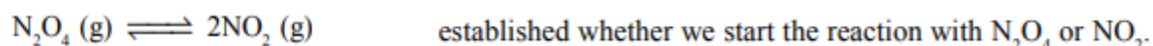

(iii) Equilibrium can be attained only in a closed system. Equilibrium can be attained only if no substance among reactants or products is allowed to escape i.e. the system is a closed one. Any system consisting of gaseous phase or volatile liquids must be kept in a closed container. Gaseous phase or volatile liquids must be kept in a closed container:

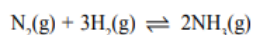

Non-volatile liquid and solid phases even in an open container:

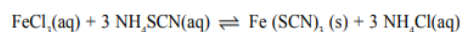

(iv) A catalyst can not change the equilibrium state. Addition of a catalyst speeds up the forward and reverse reactions by same extent and help in attaining the equilibrium faster. However, the equilibrium concentrations of reactants and products are not affected in any manner.

3. State and explain the law of chemical equilibrium.

Law of mass action states that the ‘Rate of a chemical reaction is directly proportional to the product of the concentrations of the reactants raised to their respective stoichiometric coefficients’. At equilibrium forward and backward rates are equal and the ratio of the rate constants is a constant and is known as equilibrium constant. In a reaction mixture at equilibrium, the concentrations of the reactants and products are related by an equilibrium constant. So, given a reaction:

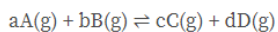

Using the Law of mass action,

$$\text{Forward reaction rate} = k_+ [\text{A}]^a [\text{B}]^b$$

$$\text{Backward reaction rate} = k_- [\text{C}]^c [\text{D}]^d$$

where, [A], [B], [C] and [D] being the active masses and k_+ and k_- are rate constants.

Forward reaction rate = Backward reaction rate

$$k_+ [\text{A}]^a [\text{B}]^b = k_- [\text{C}]^c [\text{D}]^d$$

We have,

$$K_c = k_+ / k_-$$

$$K_c = [\text{C}]^c [\text{D}]^d / [\text{A}]^a [\text{B}]^b$$

4. What is equilibrium constant? What is Kp and Kc? What are their significances?

The concentrations values in the law of equilibrium are the equilibrium concentrations of reactants and products. K_c is called the concentration equilibrium constant.

In case of gases their partial pressures can also be used in place of molar concentrations (since the two are directly proportional to each other) in the law of equilibrium. The new equilibrium constant, K_p , is called the pressure equilibrium constant.

For the reaction between H_2 and I_2

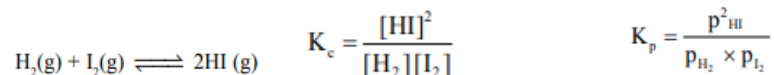

Here all are the equilibrium partial pressures of H_2 , I_2 and HI respectively. For the general gas phase reaction:

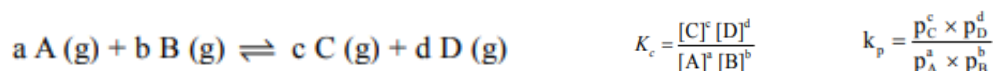

The equilibrium constant of a reaction has a constant and characteristic value at a given temperature. The changes in starting concentration, pressure and the presence of a catalyst do not change the value of the equilibrium constant. However if the temperature is changed, the value of the equilibrium constant also changes. The magnitude of the equilibrium constant is a measure of the extent upto which a reaction proceeds before the equilibrium is reached. The magnitude of K is large when the products are present in larger amounts than the reactants in the equilibrium mixture. For example;

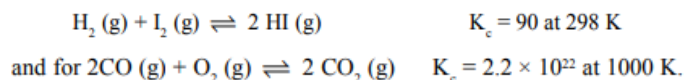

A large value of K_c for the second reaction indicates that amount of products is much more than the reactants present at the time of equilibrium. Thus the magnitude of equilibrium constant tells us about the position of the equilibrium.

5. What is the relation between equilibrium constant & Gibbs free energy? Hence explain about endothermic and exothermic reactions.

The Equilibrium constant is related to the standard Gibbs free energy change for the reaction. The relation is given by the equation:

$$\Delta G^\ominus = -RT \ln K_{eq}$$

Where, R is the universal gas constant, T is the temperature and K_{eq} is the equilibrium constant. Using the definition of Gibbs free energy & Gibbs free energy Isotherm equation, we have:

$$\begin{aligned} \Delta G^\ominus &= \Delta H^\ominus - T\Delta S^\ominus, \\ \Delta G^\ominus &= -RT \ln K_{eq}, \\ \ln K_{eq} &= -\frac{\Delta H^\ominus}{RT} + \frac{\Delta S^\ominus}{R}. \end{aligned}$$

Where, K_{eq} is the equilibrium constant at temperature T , ΔH^\ominus and ΔS^\ominus are constants and are enthalpy and entropy of the system respectively. This graph of this equation is called the Van't Hoff plot. The plot is used to estimate the enthalpy and entropy of a chemical reaction.

From the plot between “ $\ln K_{eq}$ ” & “ $1/T$ “, we have $-\Delta H/R$ as the slope, and $\Delta S/R$ as the intercept of the linear fit. Equilibrium constant K_c depends on the temperature of the reaction and the relation is given by Van't Hoff equation.

$$\ln \frac{K_2}{K_1} = \frac{-\Delta H^\ominus}{R} \left(\frac{1}{T_2} - \frac{1}{T_1} \right).$$

K_1 is the equilibrium constant at absolute temperature T_1 , K_2 is the equilibrium constant at absolute temperature T_2 , R is the ideal gas constant, ΔH reaction enthalpy assumed to be constant over the temperature range. This equation can be used to estimate a new equilibrium constant at a new absolute temperature assuming a constant standard enthalpy change over the temperature range. Let's understand the change in the equilibrium constant for two different kinds of reactions: Endothermic & Exothermic.

• Exothermic reactions

- For an exothermic reaction, heat is released, making the net enthalpy change negative.
- $\Delta H < 0$, so slope $(-\Delta H/R)$ is positive.
- Van 't Hoff plot has a positive slope.

• Endothermic reactions

- For an endothermic reaction, heat is absorbed, making the net enthalpy change positive.
- $\Delta H > 0$, so slope $(-\Delta H/R)$ is negative.
- Van 't Hoff plot has a negative slope.

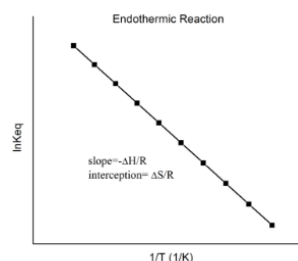
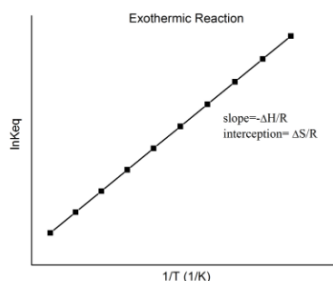

6. What are two types of chemical equilibrium? Explain about Homogeneous equilibria and Heterogeneous equilibria.

There are two types of chemical equilibria: Homogeneous equilibria and Heterogeneous equilibria

Homogeneous Equilibria. The equilibrium reactions in which all the reactants and the products are in the same phase are known as homogeneous equilibrium reactions. These are divided into two categories:

The number of product molecules is equal to the number of reactant molecules. For example:

- The number of product molecules is equal to the number of reactant molecules. For example:
 - $\text{N}_2(\text{g}) + \text{O}_2(\text{g}) \rightleftharpoons 2\text{NO}(\text{g})$
 - $\text{H}_2(\text{g}) + \text{I}_2 \rightleftharpoons 2\text{HI}(\text{g})$
- The number of product molecules is not equal to the number of reactant molecules.
 - $\text{COCl}_2(\text{g}) \rightleftharpoons \text{CO}(\text{g}) + \text{Cl}_2(\text{g})$
 - $2\text{SO}_2(\text{g}) + \text{O}_2(\text{g}) \rightleftharpoons 2\text{SO}_3(\text{g})$

- In gaseous phase,

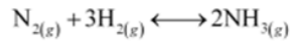

- In solution phase,

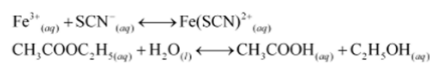

- The equilibrium constant for the homogeneous reaction in gaseous systems:
- Ideal gas equation is given by, $pV = nRT$

$$\Rightarrow p = \frac{n}{V} RT$$

If concentration C is in mol L^{-1} or mol dm^{-3} and p is in bar, then we can write $p = cRT$ or, $p = [\text{gas}] RT \dots (i)$ Where $R = 0.0831 \text{ bar L mol}^{-1} \text{ K}^{-1}$ For a general reaction,

$$aA + bB \rightleftharpoons cC + dD$$

$$K_p = \frac{(p_c^c)(p_d^d)}{(p_a^a)(p_b^b)}$$

$$= \frac{([\text{C}]RT)^c([\text{D}]RT)^d}{([\text{A}]RT)^a([\text{B}]RT)^b} \quad \text{[From equation (i)]}$$

$$= \frac{[\text{C}]^c[\text{D}]^d(RT)^{c+d}}{[\text{A}]^a[\text{B}]^b(RT)^{a+b}}$$

$$= \frac{[\text{C}]^c[\text{D}]^d}{[\text{A}]^a[\text{B}]^b}(RT)^{c+d-a-b}$$

$$= \frac{[\text{C}]^c[\text{D}]^d}{[\text{A}]^a[\text{B}]^b}(RT)^{\Delta n}$$

$$= K_c(RT)^{\Delta n} \quad \left[\text{Since, } K_c = \frac{[\text{C}]^c[\text{D}]^d}{[\text{A}]^a[\text{B}]^b} \right]$$

In the above equation, $\Delta n = (\text{number of moles of gaseous products}) - (\text{number of moles of gaseous reactants})$ in the balanced chemical equation and while calculating K_p , pressure should be expressed in bar ($1 \text{ bar} = 10^5 \text{ Pa} = 10^5 \text{ Nm}^{-2}$)

Heterogeneous Equilibria. The equilibrium reactions in which the reactants and the products are present in different phases are known as heterogeneous equilibrium reactions. For example;

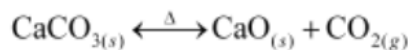

pure solids, $[\text{CaO}]$ and $[\text{CaCO}_3]$ are constants

$$K_c = \frac{[\text{CaO}_{(\text{s})}][\text{CO}_{2(\text{g})}]}{[\text{CaCO}_{3(\text{s})}]}$$

$$K'_c = [\text{CO}_{2(\text{g})}]$$

$$K_p = p_{\text{CO}_2}$$

The concentrations of pure solids like $[\text{CaO}]$ and $[\text{CaCO}_3]$ in the above case or the pure liquids to be considered as constant and do not appear in K_p expression.

Electrochemistry

1. What is EMF? Describe the measurement of EMF of a cell.

The voltage, which we usually refer to as the *cell potential*, is the potential difference between the electrodes, and is the difference between the *half-cell potentials* of the right and left sides. Each of the half-cell potentials is in turn a potential difference between the electrode and the solution, so for our example cell the above relation can be expanded as follows;

$$E_{\text{cell}} = \Delta V = V_{\text{right}} - V_{\text{left}} \qquad E_{\text{cell}} = V_{\text{Cu}} - V_{\text{soln}} + V_{\text{soln}} - V_{\text{Zn}}$$

Reversible EMF of a cell is the EMF under the condition where reaction occurring in the cell is infinitesimally slow i.e. practically no current is flowing.

When the concentrations of solutes or partial pressures of gases are not at standard conditions, the cell potential (E_{cell}) can be determined with the Nernst equation. For the general cell reaction occurring at 298 K, the Nernst equation can be rewritten as shown as follows;

$$E_{\text{cell}} = E^{\circ}_{\text{cell}} - (0.059 / n) \log Q \qquad (\text{Nernst equation})$$

Q: reaction quotient

n: moles of e^- transferred

2. Write short note on batteries.

A **battery** is an electrochemical cell or series of cells that produces an electric current. In principle, any galvanic cell could be used as a battery. An ideal battery would never run down, produce an unchanging voltage, and be capable of withstanding environmental extremes of heat and humidity. Real batteries strike a balance between ideal characteristics and practical

limitations. For example, the mass of a car battery is about 18 kg or about 1% of the mass of an average car or light-duty truck. This type of battery would supply nearly unlimited energy if used in a smartphone, but would be rejected for this application because of its mass. Thus, no single battery is “best” and batteries are selected for a particular application, keeping things like the mass of the battery, its cost, reliability, and current capacity in mind. There are two basic types of batteries: primary and secondary.

Primary batteries are single-use batteries because they cannot be recharged. A common primary battery is the dry cell (Figure). The dry cell is a zinc-carbon battery. The zinc can serves as both a container and the negative electrode. The positive electrode is a rod made of carbon that is surrounded by a paste of manganese(IV) oxide, zinc chloride, ammonium chloride, carbon powder, and a small amount of water. The reaction at the anode can be represented as the ordinary oxidation of zinc:

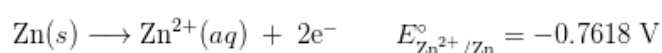

The reaction at the cathode is more complicated, in part because more than one reaction occurs. The series of reactions that occurs at the cathode is approximately

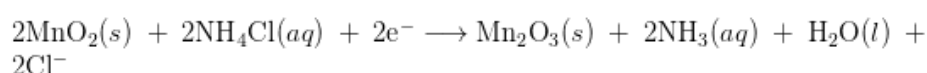

The overall reaction for the zinc-carbon battery can be represented as

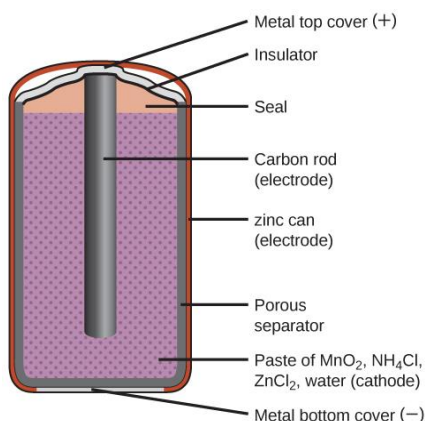
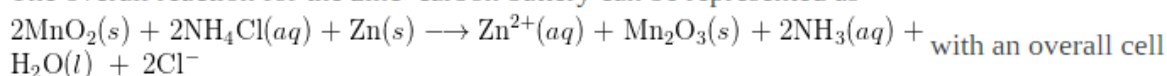

3. Describe about primary and secondary batteries with example.

Primary batteries are single-use batteries because they cannot be recharged. A common primary battery is the dry cell (Figure). The dry cell is a zinc-carbon battery. The zinc can serves as both a container and the negative electrode. The positive electrode is a rod made of carbon that is surrounded by a paste of manganese(IV) oxide, zinc chloride, ammonium chloride, carbon powder, and a small amount of water. The reaction at the anode can be represented as the ordinary oxidation of zinc:

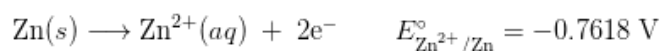

The reaction at the cathode is more complicated, in part because more than one reaction occurs. The series of reactions that occurs at the cathode is approximately

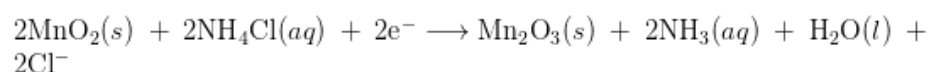

The overall reaction for the zinc-carbon battery can be represented as

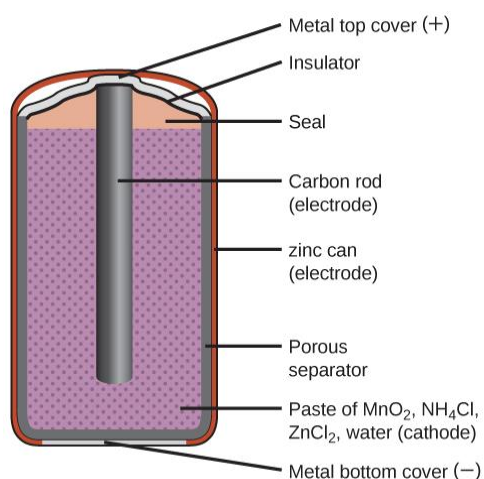
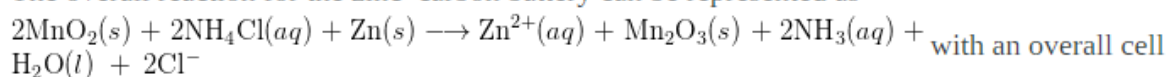

Secondary batteries are rechargeable. These are the types of batteries found in devices such as smartphones, electronic tablets, and automobiles.

Lithium ion batteries (Figure) are among the most popular rechargeable batteries and are used in many portable electronic devices. The reactions are

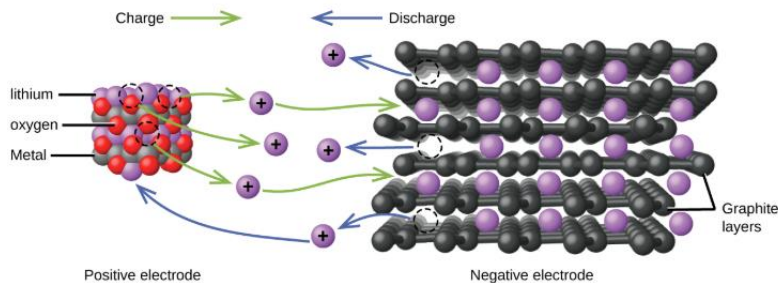
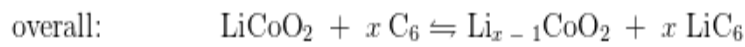
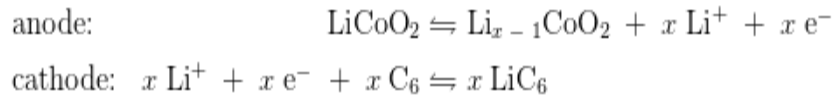

4. Describe the principle of fuel cell.

Fuel Cells

A fuel cell is a galvanic cell that requires a constant external supply of reactants because the products of the reaction are continuously removed. Unlike a battery, it does not store chemical or electrical energy; a fuel cell allows electrical energy to be extracted directly from a chemical reaction. In principle, this should be a more efficient process than, for example, burning the fuel to drive an internal combustion engine that turns a generator, which is typically less than 40% efficient, and in fact, the efficiency of a fuel cell is generally between 40% and 60%. Unfortunately, significant cost and reliability problems have hindered the wide-scale adoption of fuel cells. In practice, their use has been restricted to applications in which mass may be a significant cost factor, such as US manned space vehicles. These space vehicles use a hydrogen/oxygen fuel cell that requires a continuous input of $\text{H}_2(\text{g})$ and $\text{O}_2(\text{g})$, as illustrated in Figure. The electrode reactions are as follows:

The overall reaction represents an essentially pollution-free conversion of hydrogen and oxygen to water, which in space vehicles is then collected and used. Although this type of fuel cell should produce 1.23 V under standard conditions, in practice the device achieves only about 0.9 V. One of the major barriers to achieving greater efficiency is the fact that the four-electron reduction of $\text{O}_2(\text{g})$ at the cathode is intrinsically rather slow, which limits current that can be achieved. All major automobile manufacturers have major research programs involving fuel cells: one of the most important goals is the development of a better catalyst for the reduction of $\text{O}_2(\text{g})$.

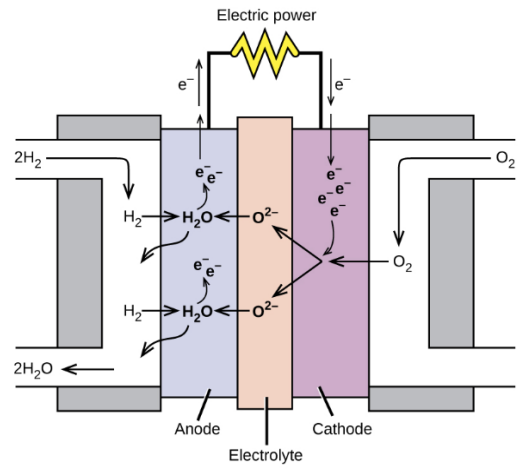
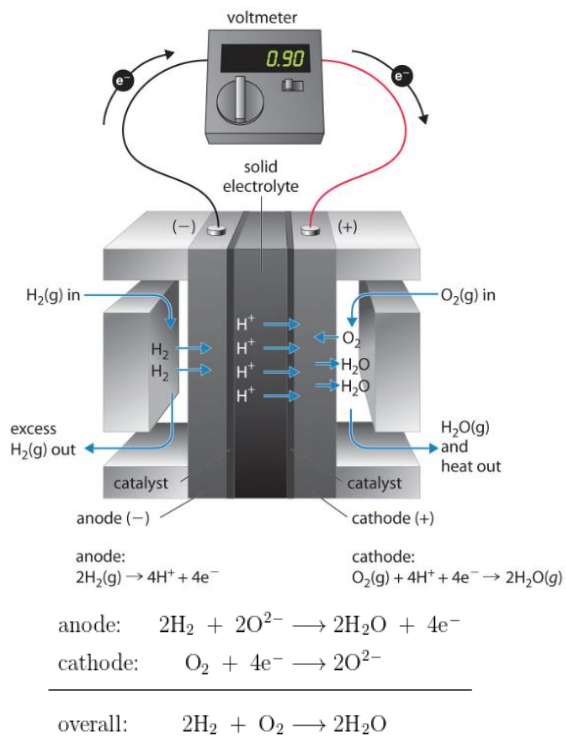

A fuel cell requires an external supply of reactants as the products of the reaction are continuously removed. In a fuel cell, energy is not stored; electrical energy is provided by a chemical reaction.