

CL5005 REACTION ENGINEERING

Lecture Notes:
Debasree Ghosh

Assistant Professor,
Department of Chemical Engineering,
Birla Institute of Technology, Mesra

MODULE

I

**CHEMICAL
REACTION
KINETICS**

Course Synopsis

- This subject covers the knowledge of reaction kinetics, reactor design and separation which distinguishes chemical engineer from other engineers.
- The course introduces the basic reactor design calculation and design of commercial chemical reactors, emphasizing synthesis of chemical kinetics and transport phenomena.
- The topics cover in this subject are kinetic rate theory, homogeneous reaction in batch and flow systems, heterogeneous reaction and catalysis, temperature effect, effect of heat transfer and catalytic reactor also reactor design, sizing and modeling of performance

Course Objectives

- Apply basic fundamentals of chemical reaction engineering such as reaction progress variables, conversion, rate laws, order of reaction and molecularity, reversible reactions and stoichiometry.
- Acquire the analytical and modeling skills required for the design and operation of industrial reactors for the chemical processes.



Typical Chemical Process

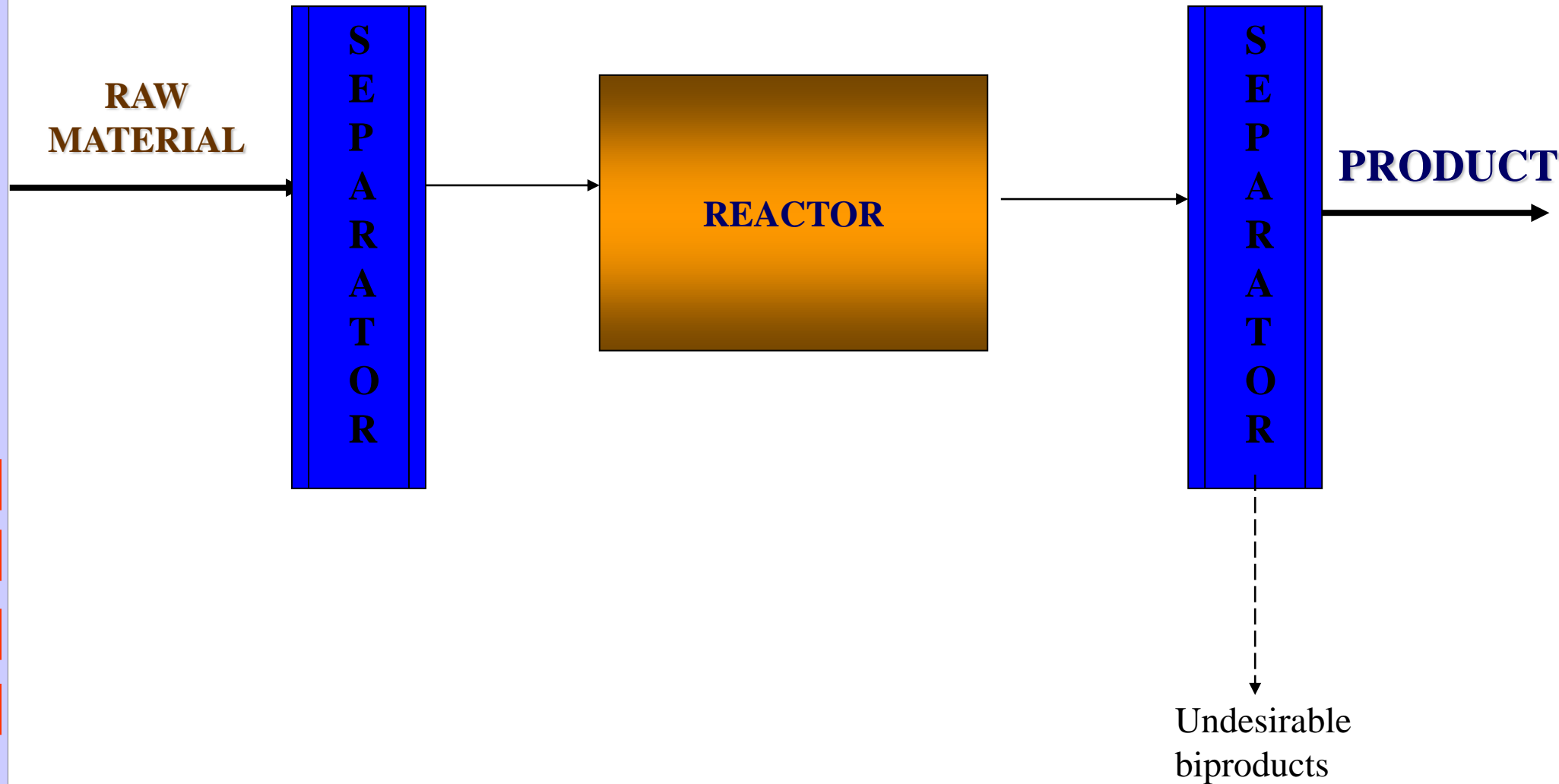

What's involved in reactor design ?

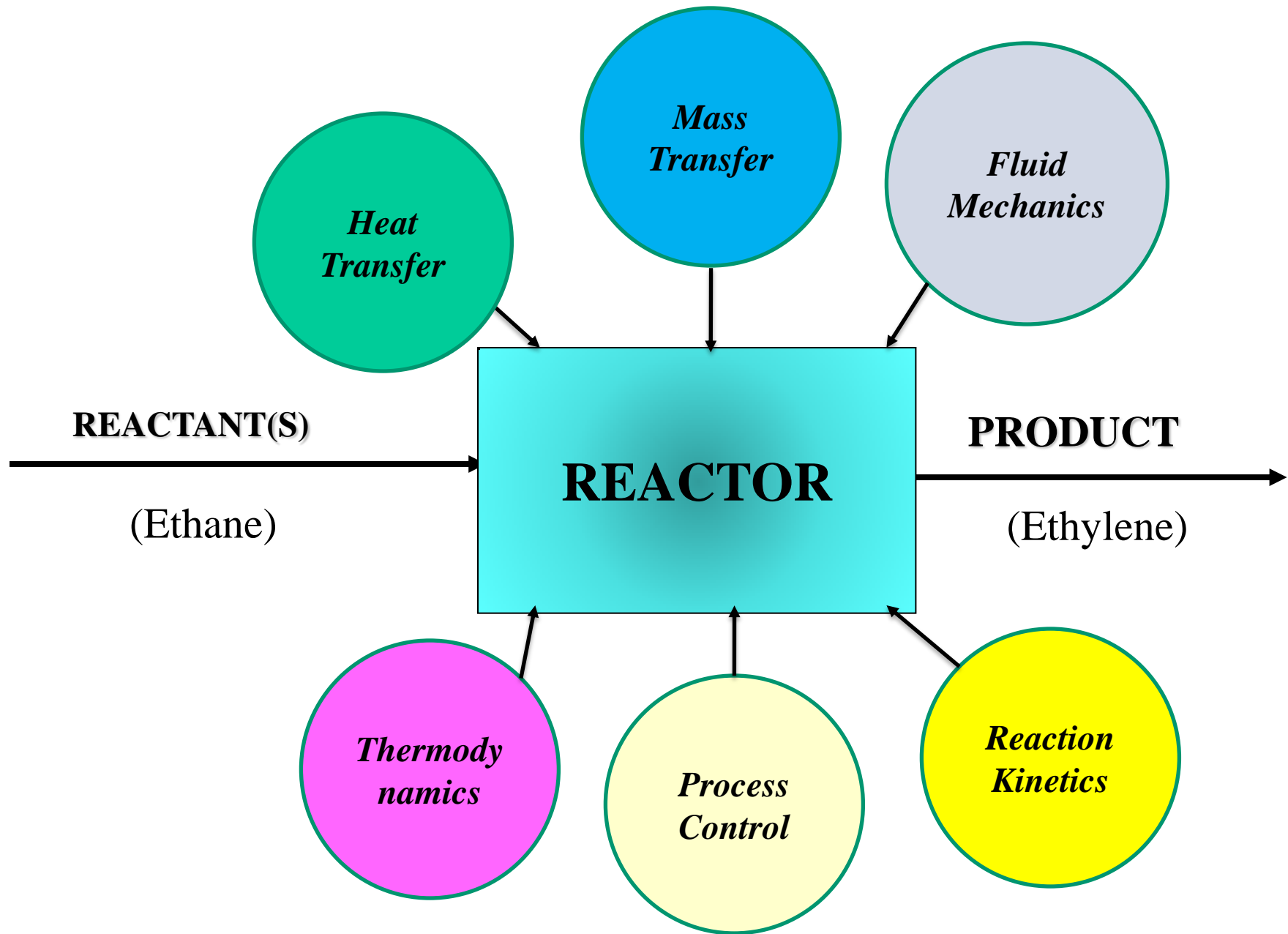

What is Chemical Reaction Engineering?

- CRE deals with chemically reactive systems of engineering significance.
- Chemical reaction engineering is the discipline that quantifies the interactions of transport phenomena and reaction kinetics in relating reactor performance to operating conditions and feed variables.
- CRE is needed in the development of *new* and the improvement of *existing* technologies.
 - search for alternative processes to replace old ones
 - novel reactors (use of metallocene catalysts)
 - find routes to make a product from different feedstock
 - novel processes for synthesis-gas production
 - Hydrocarbon production from syn gas
 - Biodiesel production
 - reduce/eliminate unwanted byproducts
 - *fuel-cells* for automobiles
 - NO_x reduction
- CRE is perhaps the key course that differentiates Chemical Engineering & Engineering Chemistry from other engineers..

CRE Application -Ethylene Production

- Ethylene is used for manufacturing *polyethylene* - the world's most widely used plastic
- NOVA Chemicals and Dow Chemical at Joffre
 - The highest capacity of any ethylene production site in the world.
 - largest single ethane based cracker in the world.

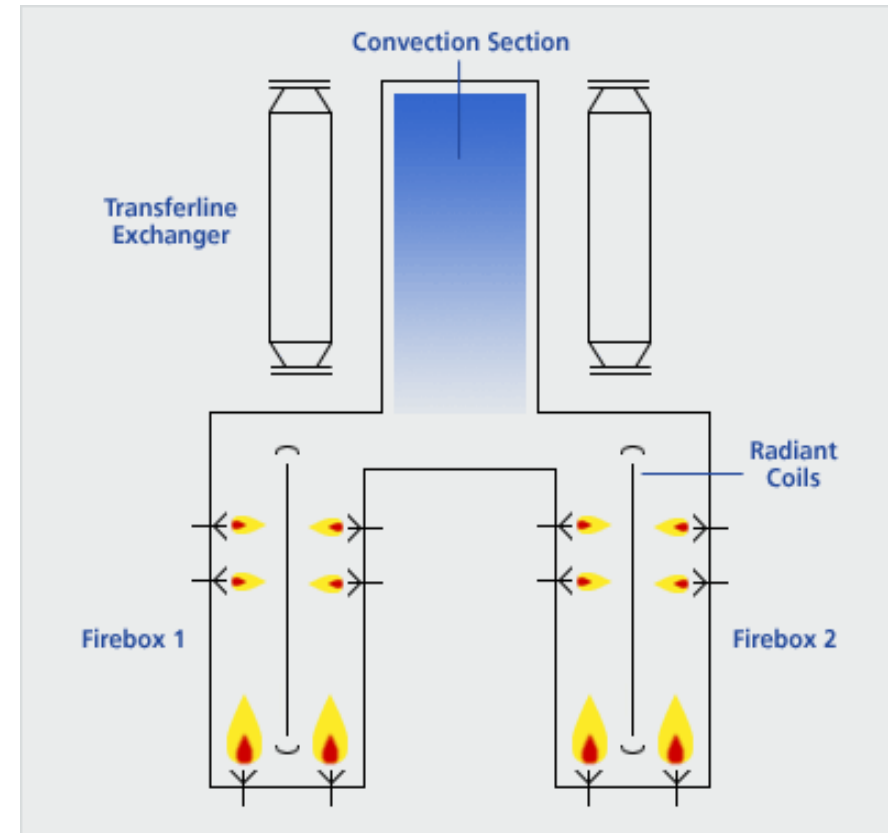

(High-temperature tubular reactors)

CRE Application - SMOG Modeling

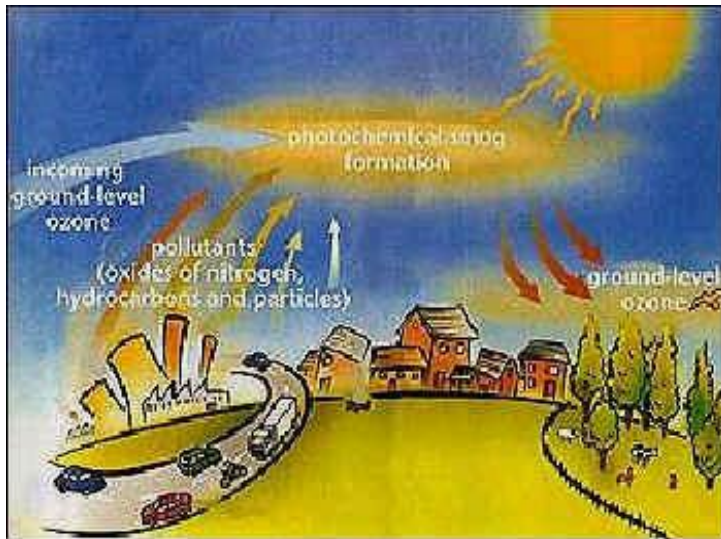

Allows us to estimate the extent of smog formation ...

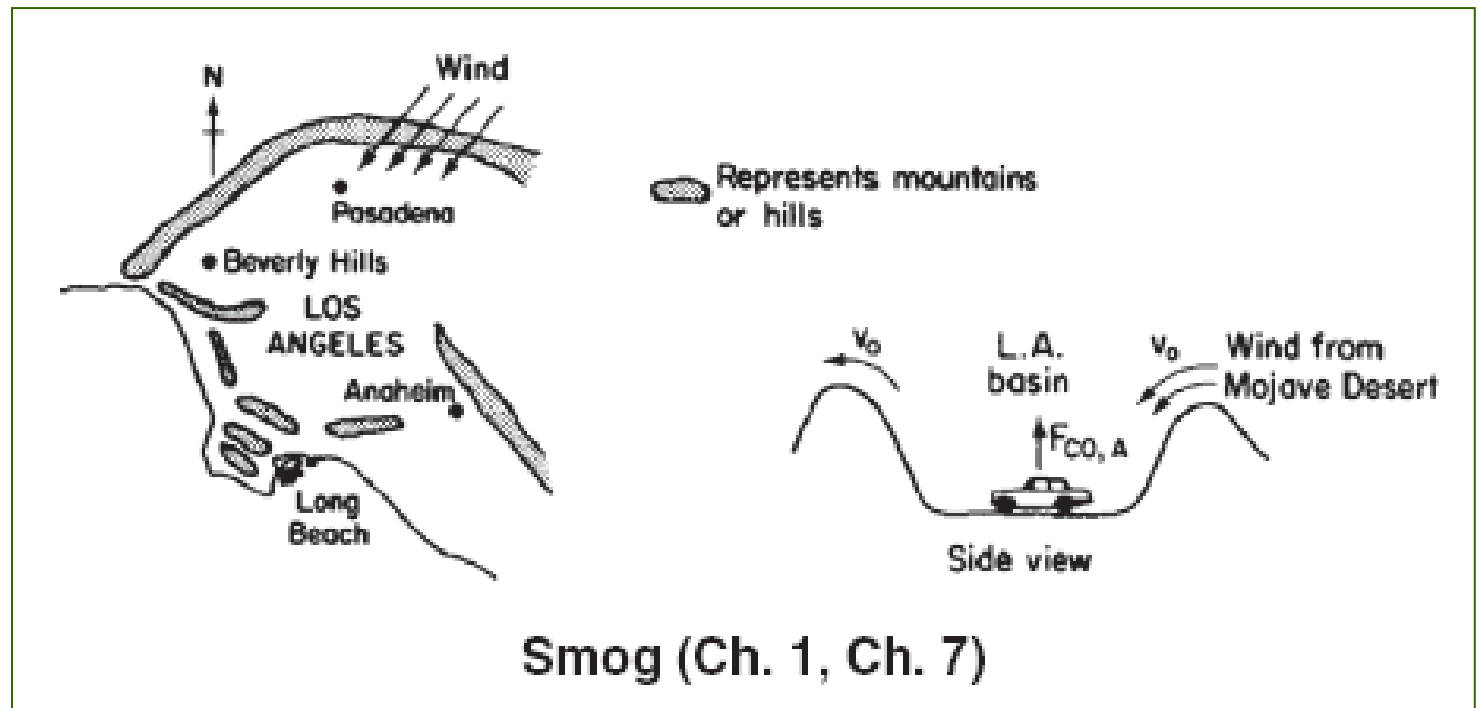

CRE Application: Reducing SMOG by Catalytic Converter

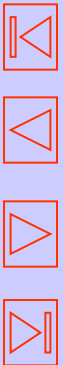
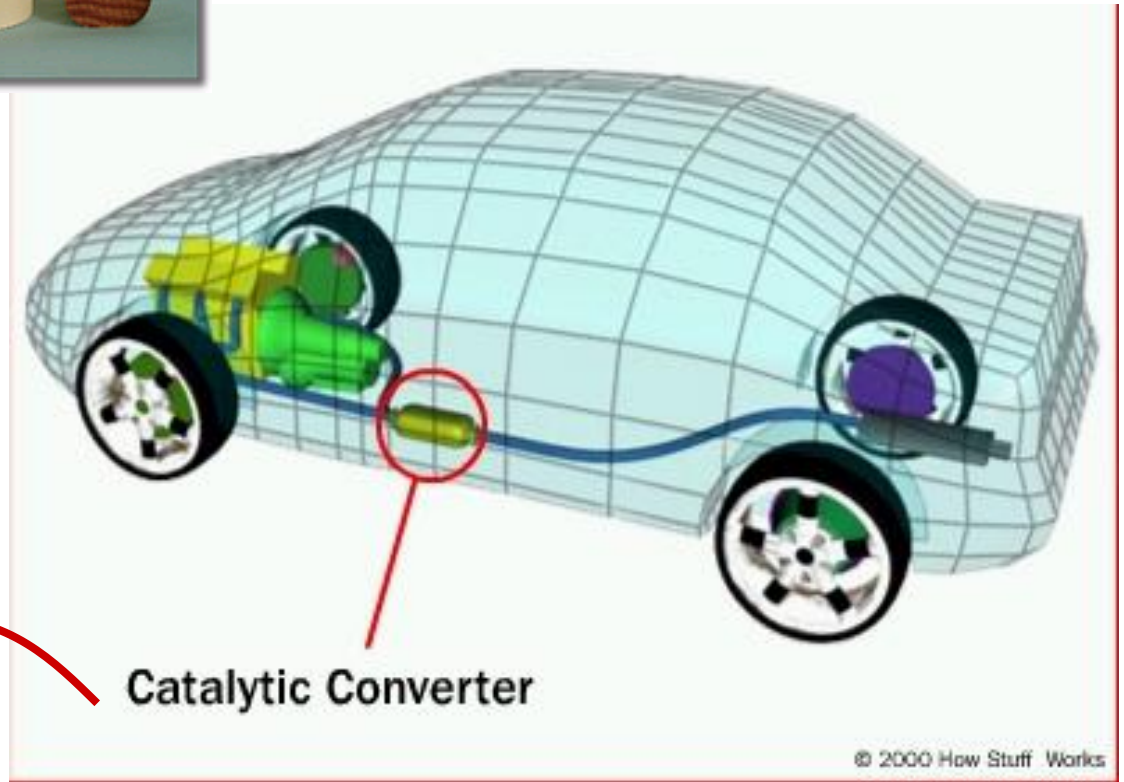

CRE Application: Large-scale growth of Stem Cells

- The challenge is to grow large quantities of viable cell....

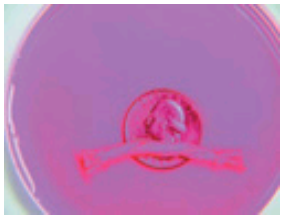

CRE Application: Pharmacokinetics

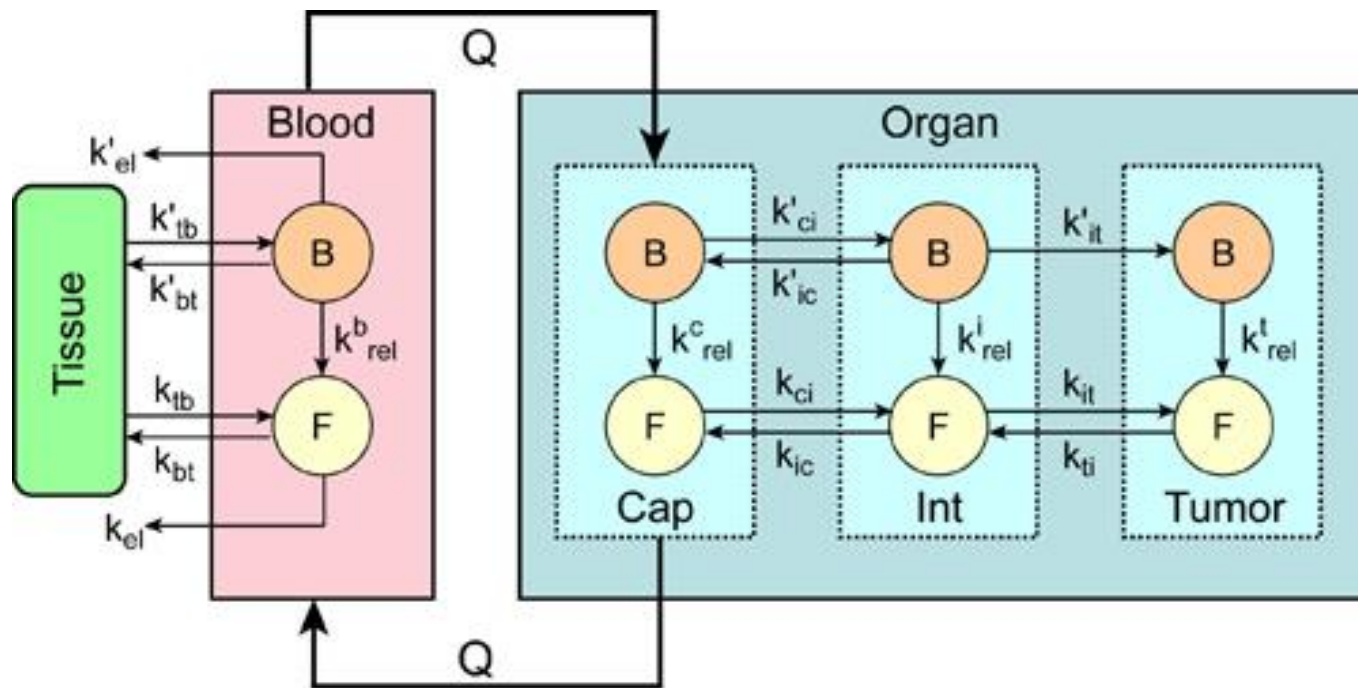

CRE can be applied to describe humanbody-drug interaction

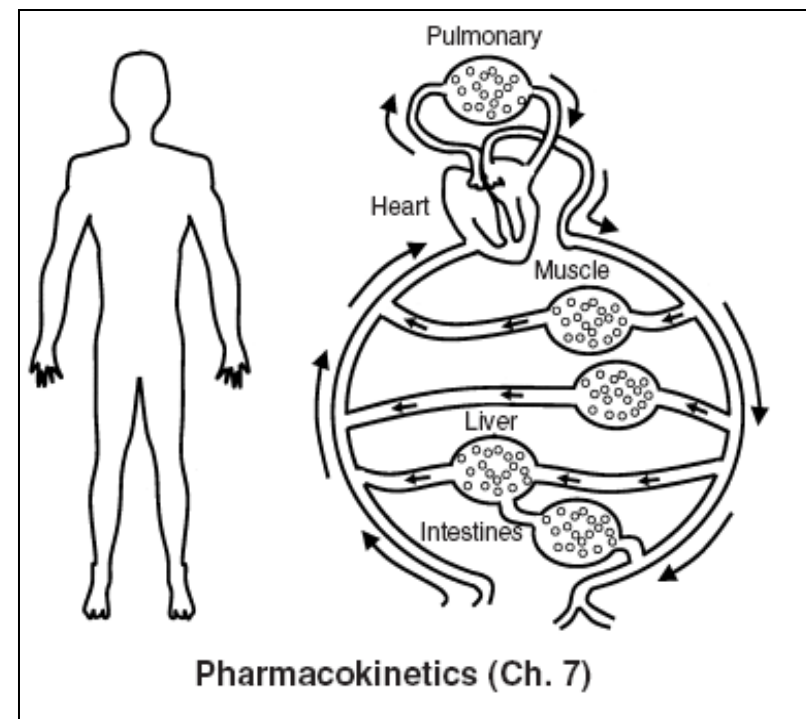

CRE Application: Fuel Cells

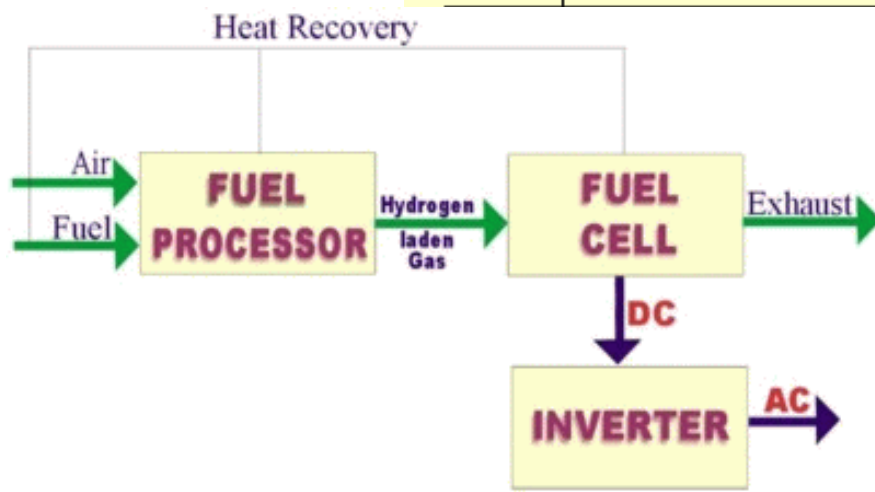
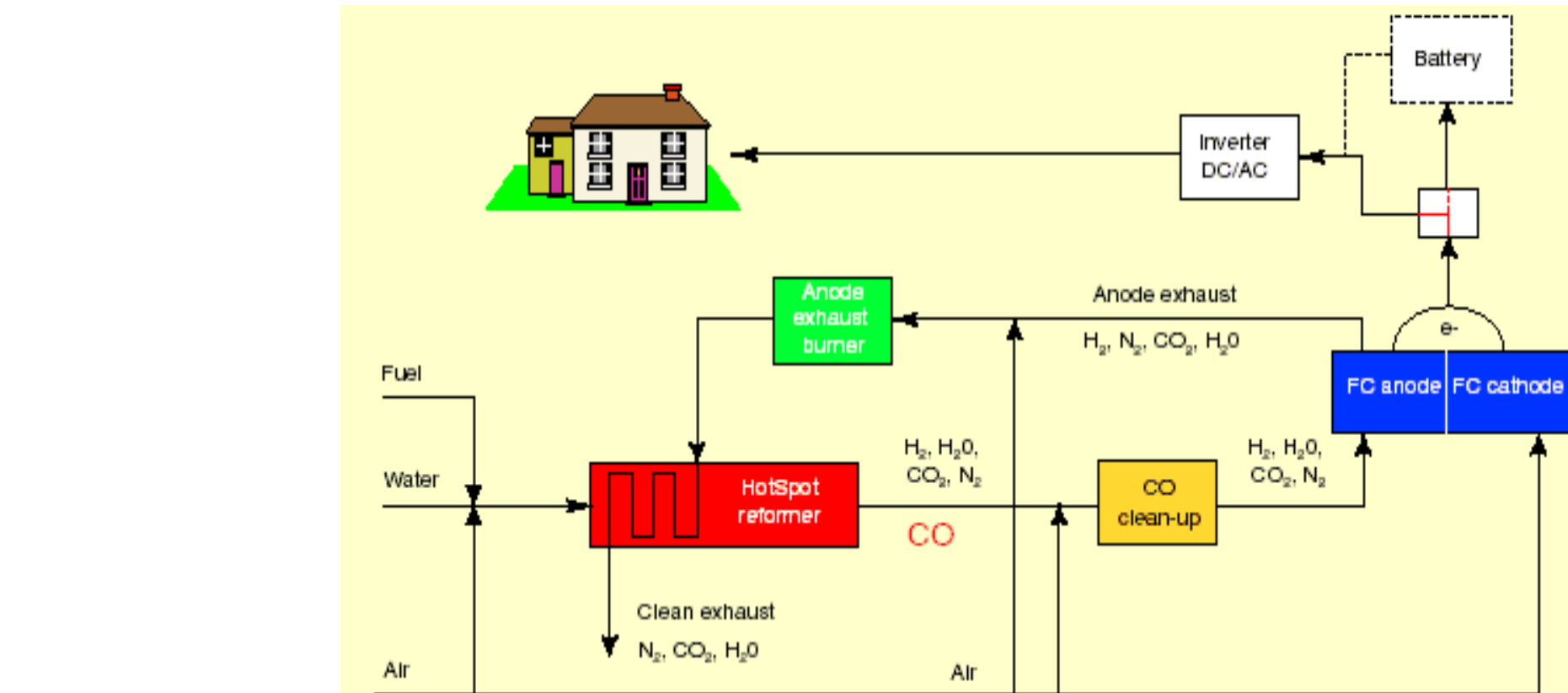

FUEL CELL SYSTEM

CRE Application – Micro-channel reactors

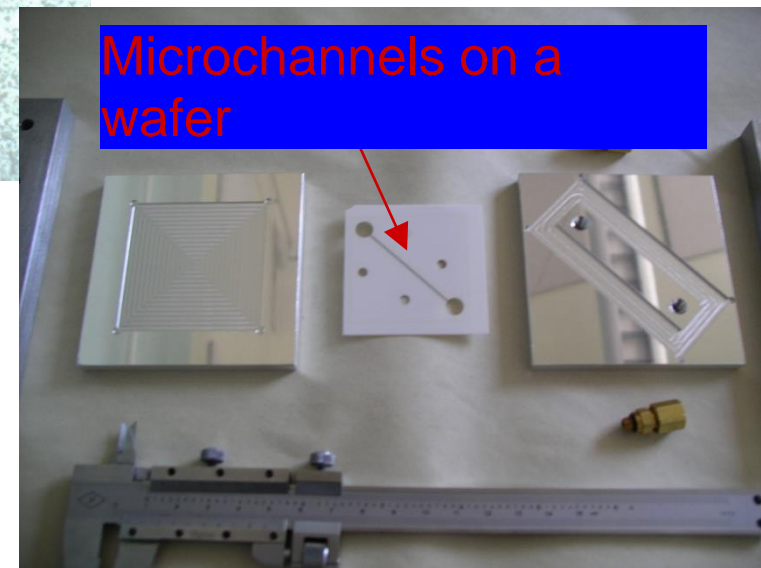
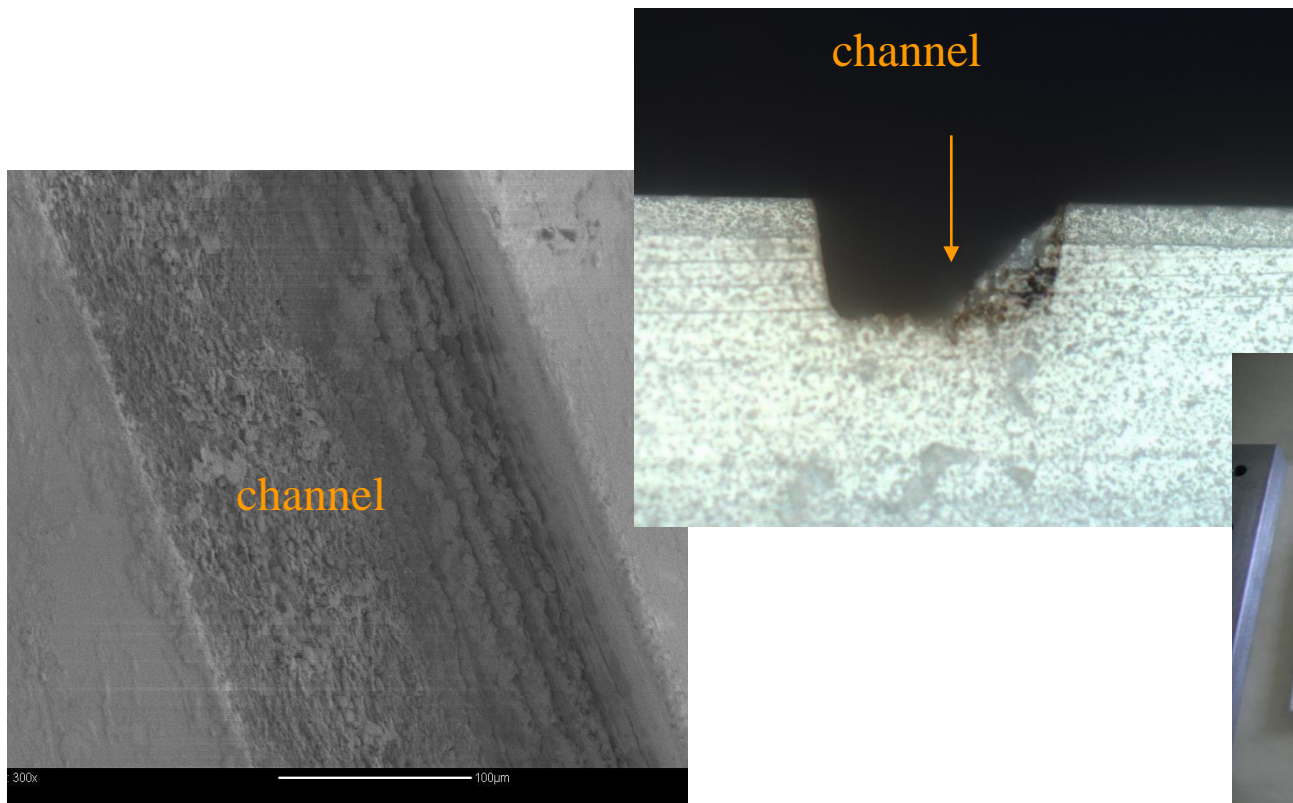

Compact reactors for compact fuel cells
Production of hazardous chemicals in controlled quantities
Potential application in bio-chemical systems.

CRE: INTRODUCTION

- Every industrial chemical process is designed to produce economically a desired product from a variety of starting materials through a succession of treatment steps.
- The subject of chemical reaction engineering initiated and evolved primarily to accomplish the task of describing how to choose, size, and determine the optimal operating conditions for a reactor whose purpose is to produce a given set of chemicals in a petrochemical application.
- The principles of chemical reaction engineering are presented in such rigor to make possible a comprehensive understanding of the subject. Mastery of these concepts will allow for generalizations to reacting systems independent of their origin and will furnish strategies for attacking different problems.
- So, Reactor design uses information, knowledge, and experience from a variety of areas-thermodynamics, chemical kinetics, fluid mechanics, heat transfer, mass transfer, and economics. Chemical reaction engineering is the synthesis of all these factors with the aim of properly designing a chemical reactor.

CRE: INTRODUCTION

- To find what a reactor is able to do we need to know the kinetics, the contacting pattern and the performance equation.
- the expression to relate input to output for various kinetics and various contacting patterns, or
- $\text{output} = f[\text{input, kinetics, contacting}]$
- This is called the *performance equation*.
- *Why is this important?*

Because with this expression we can compare different designs and conditions, find which is best, and then scale up to larger units.

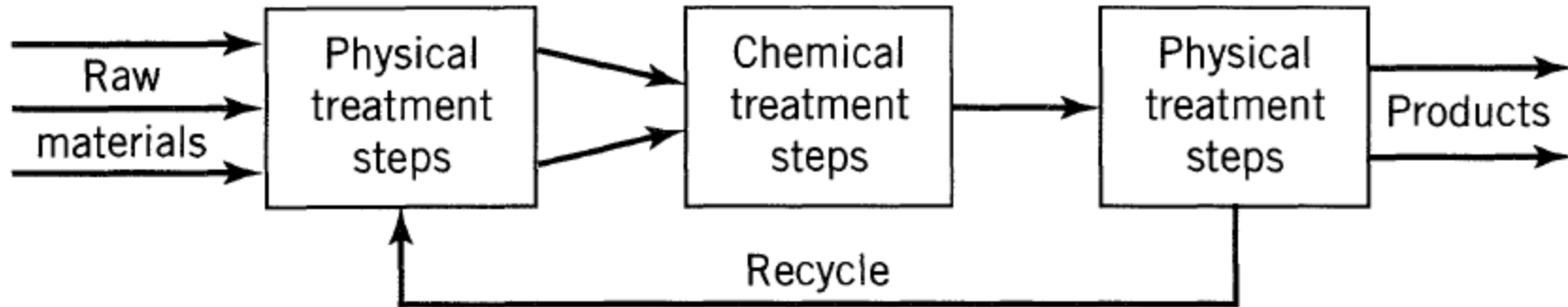

Classification of reactions

- **Classification based on state of reactant and products**

1. Homogeneous reactions

- A reaction is homogeneous if it takes place in one phase alone.

2. Heterogeneous reactions

- A reaction is heterogeneous if it requires the presence of at least two phases to proceed at the rate that it does. It is immaterial whether the reaction takes place in one, two, or more phases; at an interface; or whether the reactants and products are distributed among the phases or are all contained within a single phase. All that counts is that at least two phases are necessary for the reaction to proceed as it does.

- **Classification based on presence of catalyst**

1. Catalytic reaction

2. Non-catalytic reaction

Classification of Chemical Reactions Useful in Reactor Design

	Noncatalytic	Catalytic
Homogeneous reactions	<ul style="list-style-type: none">I. Most of gas phase reactionsII. Fast reactions such as burning of coal	<ul style="list-style-type: none">I. Most of liquid phase reactionsII. Reaction in colloidal systemsIII. Enzyme and biochemical reactions
Heterogeneous reactions	<ul style="list-style-type: none">I. Burning of coal Roasting of oresII. Attack of solids by acidsIII. Gas-liquid absorption with reactionIV. Reduction of iron ore to iron and steel	<ul style="list-style-type: none">I. Ammonia synthesisII. Oxidation of ammonia to produce nitric acidIII. Cracking of crude oilIV. Oxidation of SO₂ to SO₃

Parameters Affecting Rate of Reaction: The Rate Law

- Rate of reaction depends on a number of parameters, the most important of which are usually
 - 1. The nature of the species involved in the reaction;** Many examples of types of very fast reactions involve ions in solution, such as the neutralization of a strong acid by a strong base, and explosions. In the former case, the rate of change may be dictated by the rate at which the reactants can be brought into intimate contact. At the other extreme, very slow reactions may involve heterogeneous reactions, such as the oxidation of carbon at room temperature. The reaction between hydrogen and oxygen to form water can be used to illustrate both extremes. Subjected to a spark, a mixture of hydrogen and oxygen can produce an explosion, but in the absence of this, or of a catalyst such as finely divided platinum, the reaction is extremely slow. In such a case, it may be wrongly supposed that the system is at equilibrium, since there may be no detectable change even after a very long time.

Continued....

- 2. Concentrations of species;** Rate of reaction usually depends on concentration of reactants (and sometimes of products), and usually increases as concentration of reactants increases. Thus, many combustion reactions occur faster in pure oxygen than in air at the same total pressure.
- 3. Temperature;** Rate of reaction depends on temperature and usually increases nearly exponentially as temperature increases. An important exception is the oxidation of nitric oxide, which is involved in the manufacture of nitric acid; in this case, the rate decreases as T increases.
- 4. Catalytic activity;** Many reactions proceed much faster in the presence of a substance which is itself not a product of the reaction. This is the phenomenon of catalysis, and many life processes and industrial processes depend on it. Thus, the oxidation of SO_2 to SO_3 is greatly accelerated in the presence of V_2O_5 as a catalyst, and the commercial manufacture of sulfuric acid depends on this fact.

Continued....

- 5. Nature of contact of reactants;** The nature or intimacy of contact of reactants can greatly affect the rate of reaction. Thus, finely divided coal burns much faster than lump coal. The titration of an acid with a base occurs much faster if the acid and base are stirred together than if the base is simply allowed to “dribble” into the acid solution. For a heterogeneous, catalytic reaction, the effect may show up in a more subtle way as the dependence of rate on the size of catalyst particle used.
- 6. Wave-length of incident radiation:** Some reactions occur much faster if the reacting system is exposed to incident radiation of an appropriate frequency. thus, mixture of hydrogen and chlorine can be kept in the dark, and the reaction to form hydrogen chloride is very slow; however, if the mixture is exposed to ordinary light, reaction occurs with explosive rapidity. Such reactions are generally called photochemical reactions.

RATE EQUATIONSs

BASIS	EQUATIONS
Based on unit volume of reacting fluid	$r_i = \frac{1}{V} \frac{dN_i}{dt} = \frac{\text{moles } i \text{ formed}}{(\text{volume of fluid}) (\text{time})}$
Based on unit mass of solid in fluid-solid systems	$r'_i = \frac{1}{W} \frac{dN_i}{dt} = \frac{\text{moles } i \text{ formed}}{(\text{mass of solid}) (\text{time})}$
Based on unit interfacial surface in two-fluid systems or based on unit surface of solid in gas-solid systems	$r''_i = \frac{1}{S} \frac{dN_i}{dt} = \frac{\text{moles } i \text{ formed}}{(\text{surface}) (\text{time})}$
Based on unit volume of solid in gas-solid systems	$r'''_i = \frac{1}{V_s} \frac{dN_i}{dt} = \frac{\text{moles } i \text{ formed}}{(\text{volume of solid}) (\text{time})}$
Based on unit volume of reactor, if different from the rate based on unit volume of fluid,	$r''''_i = \frac{1}{V_r} \frac{dN_i}{dt} = \frac{\text{moles } i \text{ formed}}{(\text{volume of reactor}) (\text{time})}$

Kinetics of Homogeneous Reactions

- Let us consider a single phase reaction

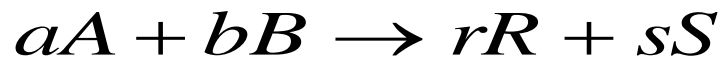

- Therefore the rate of consumption of A is defined as

$$-r_A = -\frac{1}{V} \frac{dN_A}{dt} = \left[\frac{\text{mols}}{\text{m}^3 \cdot \text{s}} \right]$$

- the rates of reaction of all materials are related by

$$\frac{-r_A}{a} = \frac{-r_B}{b} = \frac{r_R}{r} = \frac{r_S}{s}$$

Single and Multiple Reactions

- When a single stoichiometric equation and single rate equation are chosen to represent the progress of the reaction, we have a *single reaction*.

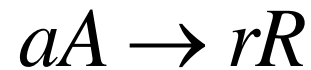

- When more than one stoichiometric equation is chosen to represent the observed changes then more than one kinetic expression is needed to follow the changing composition of all the reaction components, and we have *multiple reactions*.
- Multiple reactions are of classified as:

1. Series reactions



2. Parallel reactions
3. More complicated reactions

Elementary and Nonelementary Reactions

- Let us Consider a single reaction with stoichiometric equation



- So rate equation may be written as $-r_A = kC_A C_B$
- Such reactions in which the rate equation corresponds to a stoichiometric equation are called *elementary reactions*.
- When there is no direct correspondence between stoichiometry and rate, then we have *nonelementary reactions*.
- *The classical example of a nonelementary reaction is that between hydrogen and bromine,*

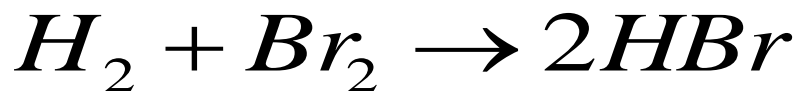

- And the corresponding rate equation is

$$r_{HBr} = \frac{k_1[H_2][Br_2]^{1/2}}{k_2 + [HBr]/[Br_2]}$$

Molecularity and Order of Reaction

- The **molecularity** of an elementary reaction is the number of molecules involved in the reaction, and this has been found to have the values of one, two, or occasionally three.
- Let us consider a rate equation

$$-r_A = kC_A^a C_B^b C_C^c C_D^d \dots\dots \text{and}$$

$$a + b + c + d = n$$

- where a, b, . . . , d are not necessarily related to the stoichiometric coefficients.
- We call the powers to which the concentrations are raised the **order** of the reaction. Thus, the reaction is ath order with respect to A, bth **order** with respect to B, nth **order** overall.
- Since the order refers to the empirically found rate expression, it can have a fractional value and need not be an integer. However, the molecularity of a reaction must be an integer because it refers to the mechanism of the reaction, and can only apply to an elementary reaction.

Rate Constant

- The rate constant is denoted by k as shown in the equation given below

$$-r_A = kC_A C_B$$

- And the unit of k for n th-order equation is $(\text{time})^{-1} (\text{concentration})^{1-n}$
- For many reactions, and particularly elementary reactions, the rate expression can be written as a product of a temperature-dependent term and a composition-dependent term.
- According to Arrhenius' Law the temperature dependent term is the rate constant and the relation is

$$k = k_0 e^{-E/RT}$$

- According Collision and transition theory the relation is as follows

$$k = k_0' T^m e^{-E/RT}$$

$$0 \leq m \leq 1$$

Activation Energy and Temperature Dependency

1. From Arrhenius' law a plot of $\ln k$ vs. $1/T$ gives a straight line, with large slope for large E and small slope for small E .
2. Reactions with high activation energies are very temperature-sensitive; reactions with low activation energies are relatively temperature-insensitive.
3. Any given reaction is much more temperature-sensitive at a low temperature than at a high temperature.
4. From the Arrhenius law, the value of the frequency factor k_0 , *does not affect* the temperature sensitivity.

Kinetic models for nonelementary reactions

- A nonelementary reaction is one whose stoichiometry does not match its kinetics.

- For example
$$\text{N}_2 + 3\text{H}_2 \rightleftharpoons 2\text{NH}_3$$

$$r_{\text{NH}_3} = k_1 \frac{[\text{N}_2][\text{H}_2]^{3/2}}{[\text{NH}_3]^2} - k_2 \frac{[\text{NH}_3]}{[\text{H}_2]^{3/2}}$$

- This non-match shows that we must try to develop a multistep reaction model to explain the kinetics.
- To explain the kinetics of nonelementary reactions we assume that a sequence of elementary reactions is actually occurring but that we cannot measure or observe the intermediates formed because they are only present in very minute quantities. Thus, we observe only the initial reactants and final products, or what appears to be a single reaction.

Reaction mechanism of nonelementary reactions

1. Free radicals, chain reaction mechanism

The reaction of hydrogen and bromine with some specific condition can be explained with this model.

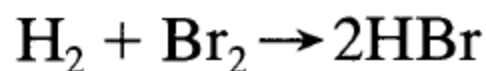

$$r_{\text{HBr}} = \frac{k_1[\text{H}_2][\text{Br}_2]^{1/2}}{k_2 + [\text{HBr}]/[\text{Br}_2]}$$

Mechanism:

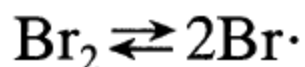

Initiation and termination

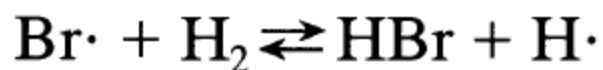

Propagation

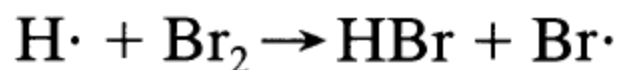

Propagation

2. Molecular intermediates, non-chain mechanism.

The general class of enzyme-catalyzed fermentation reactions with experimental rate

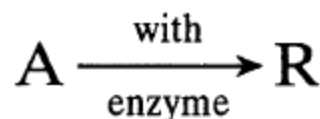

$$r_{\text{R}} = \frac{k[\text{A}][\text{E}_0]}{[\text{M}] + [\text{A}]}$$

constant

Continued.....

In such reactions the concentration of intermediate may become more than negligible, in which case a special analysis, first proposed by Michaelis and Menten (1913), is required.

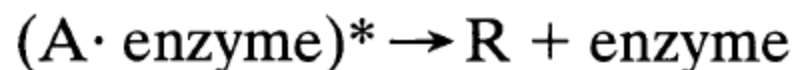
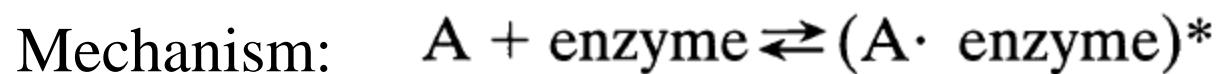

3. *Transition complex, non-chain mechanism.*

According to Lindenann (1922) the spontaneous decomposition of azo-methane exhibits under various conditions first-order, second-order, or intermediate kinetics. This type of behavior can be explained by postulating the existence of an energized and unstable form for the reactant, A^* . Thus,

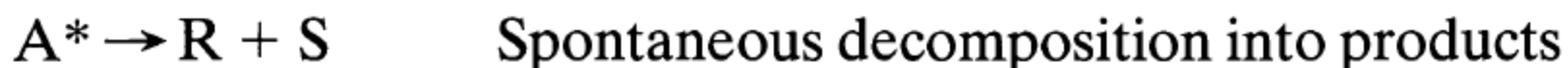
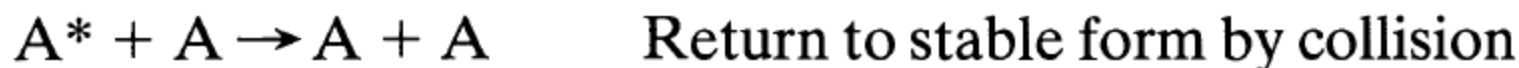
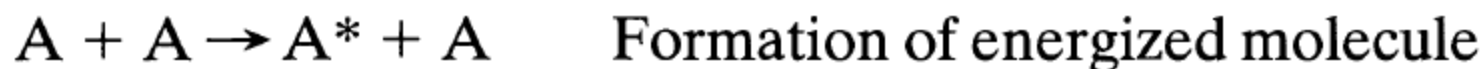
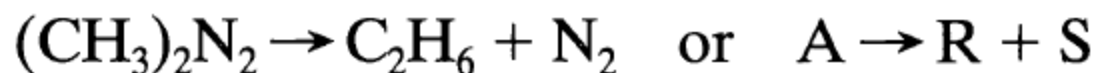

Reactor Design and Analysis of Performance

- Reactor design embodies many different facets and disciplines, the details of some of which are outside our scope. here, we focus on process design as opposed to mechanical design of equipment . Other aspects are implicit, but are not treated explicitly: instrumentation and process control, economic, and socioeconomic (environmental and safe-operation). Reactor design is a term we may apply to a new installation or modification;
- **Parameters Affecting Reactor Performance:** The term “reactor performance” usually refers to the operating results achieved by a reactor, particularly with respect to fraction of reactant converted or product distribution for a given size and configuration; alternatively, it may refer to size and configuration for a given conversion or distribution. In any case, it depends on two main types of behavior: (1) rates of processes involved, including reaction and heat and mass transfer, sometimes influenced by equilibrium limitations; and (2) motion and relative-motion of elements of fluid (both single-phase and multiphase situations) and solid particles (where involved), whether in a flow system or not.

Continued....

- At this stage, type (1) is more apparent than type (2) and we provide some preliminary discussion of (2) here. Flow characteristics include relative times taken by elements of fluid to pass through the reactor (residence-time distribution), and mixing characteristics for elements of fluid of different ages: point(s) in the reactor at which mixing takes place, and the level of segregation at which it takes place (as a molecular dispersion or on a macroscopic scale). Lack of sufficient information on one or both of these types is a major impediment to a completely rational reactor design.



Interpretation of batch reactor data

- A rate equation characterizes the rate of reaction, and its form may either be suggested by theoretical considerations or simply be the result of an empirical curve-fitting procedure. In any case, the value of the constants of the equation can only be found by experiment; predictive methods are inadequate at present.
- The determination of the rate equation is usually a two-step procedure; first the concentration dependency is found at fixed temperature and then the temperature dependence of the rate constants is found, yielding the complete rate equation.
- Equipment by which empirical information is obtained can be divided into two types, the batch and *flow reactors*. *The batch reactor is simply a container* to hold the contents while they react. All that has to be determined is the extent of reaction at various times, and this can be followed in a number of ways, for example:

Continued.....

1. By following the concentration of a given component.
 2. By following the change in some physical property of the fluid, such as the electrical conductivity or refractive index.
 3. By following the change in total pressure of a constant-volume system.
 4. By following the change in volume of a constant-pressure system.
- The experimental **batch reactor** is usually operated **isothermally** and at **constant volume** because it is easy to interpret the results of such runs.
 - The **flow reactor** is used primarily in the study of the kinetics of **heterogeneous** reactions.
 - There are two procedures for analyzing kinetic data, the *integral* and the *differential* methods.

Comparison of differential and integral method

Differential method	Integral method
<p>In the differential method of analysis we test the fit of the rate expression to the data directly and without any integration. However, since the rate expression is a differential equation, we must first find $(1/V)(dN/dt)$ from the data before attempting the fitting procedure.</p>	<p>In the integral method of analysis we guess a particular form of rate equation and, after appropriate integration and mathematical manipulation, predict that the plot of a certain concentration function versus time should yield a straight line. The data are plotted, and if a reasonably good straight line is obtained, then the rate equation is said to satisfactorily fit the data.</p>
<p>The differential method is useful in more complicated situations but requires more accurate or larger amounts of data</p>	<p>The integral method is easy to use and is recommended when testing specific mechanisms, or relatively simple rate expressions.</p>
<p>the differential method can be used to develop or build up a rate equation to fit the data.</p>	<p>The differential method is useful in more complicated situations but requires more accurate or larger amounts of data</p>

Constant-volume Batch Reactor

- When the constant-volume batch reactor is considered it refers to the volume of reaction mixture, and not the volume of reactor. Thus, this term actually means a *constant-density reaction system*.
- *Most liquid-phase reactions* as well as all gas-phase reactions occurring in a constant-volume bomb fall in this class.
- In a constant-volume system the measure of reaction rate of component i becomes

$$r_i = \frac{1}{V} \frac{dN_i}{dt} = \frac{d(N_i/V)}{dt} = \frac{dC_i}{dt}$$

- For ideal gases

$$C_i = p_i / RT$$

$$r_i = \frac{d(p_i / RT)}{dt} = \frac{1}{RT} \frac{dp_i}{dt}$$

Analysis of Total Pressure Data Obtained in a Constant-Volume System

- For isothermal gas reactions where the number of moles of material changes during reaction, let us develop the general expression which relates the changing total pressure of the system π to the changing concentration or partial pressure of any of the reaction components.
- Let rate equation is



- At time $t = 0$ the amount of reactant and product along with inert are N_{A0} , N_{B0} , N_{R0} , N_{S0} , N_{inert}
- At time t the above amount are $(N_{A0} - ax)$, $(N_{B0} - bx)$, $(N_{R0} + rx)$, $(N_{S0} + sx)$, N_{inert}

- Let $N_0 = N_{A0} + N_{B0} + \dots + N_{R0} + N_{S0} + \dots + N_{\text{inert}}$

- At time t $N = N_0 + x(r + s + \dots - a - b - \dots) = N_0 + x \cdot \Delta n$

- or
$$C_A = \frac{p_A}{RT} = \frac{N_A}{V} = \frac{N_{A0} - ax}{V} = \frac{N_{A0}}{V} - \frac{a}{\Delta n} \frac{N - N_0}{V}$$

Conversion

- Suppose that N_{A0} is the initial amount of A in the reactor at time $t = 0$, and that N_A is the amount present at time t . Then the conversion of A in the constant volume system is given by

$$X_A = \frac{N_{A0} - N_A}{N_{A0}} = 1 - \frac{N_A / V}{N_{A0} / V} = 1 - \frac{C_A}{C_{A0}}$$

- or
$$dX_A = -\frac{dC_A}{C_{A0}}$$

Integral Method of Analysis of Data

Type of reaction	reaction	Relation between conversion and time
Irreversible uni-molecular-type first order reaction	$A \rightarrow \text{product}$	$-\ln(1 - X_A) = kt$
Irreversible Bimolecular-Type Second-Order Reactions	$A + B \rightarrow \text{product}$	$\int_0^{X_A} \frac{dX_A}{(1 - X_A)\left(\frac{C_{B0}}{C_{A0}} - X_A\right)} = C_{A0}kt$
Irreversible Tri-molecular-Type Third-Order Reactions	$A + B + C \rightarrow \text{product}$	$\int_0^{X_A} \frac{dX_A}{(1 - X_A)\left(\frac{C_{B0}}{C_{A0}} - X_A\right)\left(\frac{C_{C0}}{C_{A0}} - X_A\right)} = C_{A0}^2kt$

Overall Order of Irreversible Reactions from the Half-Life

- The half-life of the reaction is defined *as the time needed for the concentration* of reactants to drop to one-half the original value.
- Let us consider the decay of reactant A as per following rate equation

$$-r_A = -\frac{dC_A}{dt} = kC_A^n$$

- For $n \neq 1$

$$C_A^{1-n} - C_{A0}^{1-n} = k(n-1)t$$

- Therefore half-life is given by

$$t_{1/2} = \frac{(0.5)^{1-n} - 1}{k(n-1)} C_{A0}^{1-n}$$

- **Fractional Life Method**

$$t_F = \frac{(F)^{1-n} - 1}{k(n-1)} C_{A0}^{1-n}$$

- Thus, a plot of $\log t_F$ versus $\log C_{A0}$, *will give the reaction order.*

Mechanism of Irreversible Reactions in Parallel

- Consider the simplest case, A decomposing by two competing paths, both elementary reactions:

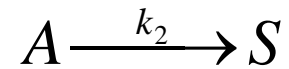
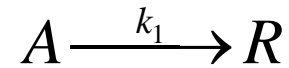

- The rates of change of the three components are given by

$$-r_A = -\frac{dC_A}{dt} = (k_1 + k_2)C_A$$

$$r_R = \frac{dC_R}{dt} = k_1 C_A$$

$$r_S = \frac{dC_S}{dt} = k_2 C_A$$

- The k values are found using all three differential rate equations.

$$-\ln \frac{C_A}{C_{A0}} = (k_1 + k_2)t \quad \text{and} \quad \frac{r_R}{r_S} = \frac{dC_R}{dC_S} = \frac{k_1}{k_2} = \frac{C_R - C_{R0}}{C_S - C_{S0}}$$

- Thus, the slope of a plot of C_R versus C_S gives the ratio k_1/k_2 . *Knowing k_1/k_2 as well as $k_1 + k_2$ gives k_1 and k_2 .*

Homogeneous Catalyzed Reactions

- Suppose the reaction rate for a homogeneous catalyzed system is the sum of rates of both the un-catalyzed and catalyzed reactions,

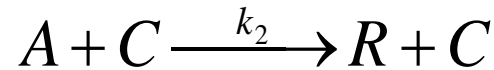
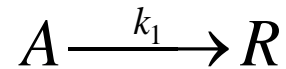

- And the corresponding rate equations are

$$-\left(\frac{dC_A}{dt}\right)_1 = k_1 C_A$$

$$-\left(\frac{dC_A}{dt}\right)_2 = k_2 C_A C_C$$

$$-\left(\frac{dC_A}{dt}\right)_{\text{overall}} = k_1 C_A + k_2 C_A C_C = (k_1 + k_2 C_C) C_A$$

- As concentration of catalyst remains unchanged

$$-\ln \frac{C_A}{C_{A0}} = (k_1 + k_2 C_C) t$$

Autocatalytic Reactions

- A reaction in which one of the products of reaction acts as a catalyst is called an autocatalytic reaction. The simplest such reaction with rate equation is

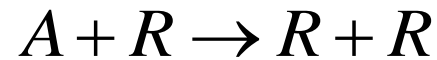

$$-r_A = -\frac{dC_A}{dt} = kC_A C_R$$

- Because the total number of moles of A and R remain unchanged as A is consumed, we may write that at any time

$$C_0 = C_A + C_R = C_{A0} + C_{R0} = \text{constan } t$$

- So rate equation becomes
$$-r_A = -\frac{dC_A}{dt} = kC_A (C_0 - C_A)$$

- By integrating the above equation we get

$$\ln \frac{C_R / C_{R0}}{C_A / C_{A0}} = (C_{A0} + C_{R0})kt$$

Continued...

- For an autocatalytic reaction in a batch reactor some product R must be present if the reaction is to proceed at all.
- Starting with a very small concentration of R, and the rate will rise as R is formed.
- At the other extreme, when A is just about used up the rate must drop to zero. This result is that the rate follows a parabola, with a maximum where the concentrations of A and R are equal.



Irreversible Reactions in Series

- Let us consider consecutive unimolecular first order reactions are in series and is given by:



- And the rate equations are

$$r_A = \left(\frac{dC_A}{dt} \right) = -k_1 C_A$$

$$r_R = \left(\frac{dC_R}{dt} \right) = k_1 C_A - k_2 C_R$$

$$r_S = \left(\frac{dC_S}{dt} \right) = k_2 C_R$$

- By integrating the first rate equation with respect to reactant A starting with initial concentration C_{A0} we get

$$-\ln \frac{C_A}{C_{A0}} = k_1 t \quad \text{or} \quad C_A = C_{A0} e^{-k_1 t}$$

Continued...

- To find the changing concentration of R, substitute the above expression for concentration of A from into the differential equation governing the rate of change of R, and the equation becomes

$$\frac{dC_R}{dt} + k_2 C_R = k_1 C_{A0} e^{-k_1 t}$$

- The above differential equation will be solved with the help of integrating factor and the solution becomes

$$C_R = C_{A0} k_1 \left(\frac{e^{-k_1 t}}{k_2 - k_1} + \frac{e^{-k_2 t}}{k_1 - k_2} \right)$$

- As there is no change in total number of moles, the stoichiometric relates the concentrations of reacting components by $C_{A0} = C_A + C_R + C_S$

- And $C_S = C_{A0} \left(1 + \frac{k_2}{k_1 - k_2} e^{-k_1 t} + \frac{k_1}{k_2 - k_1} e^{-k_2 t} \right)$

Continued....

- **Special cases**
- **Case I:** Now if k_2 is much larger than k_1 ,

$$C_S = C_{A0} (1 - e^{-k_1 t}), \quad k_2 \gg k_1$$

- In other words, the rate is determined by k_1 or the first step of the two-step reaction.
- **Case II:** If k_1 is much larger than k_2 , then

$$C_S = C_{A0} (1 - e^{-k_2 t}), \quad k_1 \gg k_2$$

- which is a first-order reaction governed by k_2 , the slower step in the two-step reaction. Thus, in general, **for any number of reactions in series it is the slowest step that has the greatest influence on the overall reaction rate.**
- **Case III:** The time at which the maximum concentration of R occurs i.e.

$$dC_R/dt = 0.$$

- And the maximum time is

$$t_{\max} = \frac{1}{k_{\log \text{ mean}}} = \frac{\ln(k_2/k_1)}{k_2 - k_1}$$

Continued...

- The maximum concentration of R is

$$\frac{C_{R,\max}}{C_{A0}} = \left(\frac{k_1}{k_2}\right)^{k_2/(k_2-k_1)}$$

- From the results for this particular reaction we can conclude that
 1. A decreases exponentially, R rises to a maximum and then falls, and S rises continuously, the greatest rate of increase of S occurring where R is a maximum.
 2. In particular, one can evaluate k_1 and k_2 by noting the maximum concentration of intermediate and the time when this maximum is reached.

First-Order Reversible Reactions

- Let us consider reactions for which complete conversion cannot be assumed. The simplest case is the opposed unimolecular-type reaction

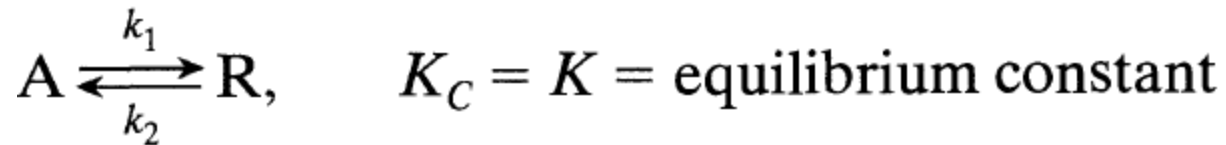

- Starting with a concentration ratio $M = C_{A0}/C_{R0}$ the rate equation is

$$\begin{aligned} \frac{dC_R}{dt} &= -\frac{dC_A}{dt} = C_{A0} \frac{dX_A}{dt} = k_1 C_A - k_2 C_R \\ &= k_1 (C_{A0} - C_{A0} X_A) - k_2 (M C_{A0} + C_{A0} X_A) \end{aligned}$$

- At equilibrium $dC_A/dt = 0$

- Therefore
$$K_C = \frac{C_{Re}}{C_{Ae}} = \frac{M + X_{Ae}}{1 - X_{Ae}}$$

- And the equilibrium constant to be
$$K_C = \frac{k_1}{k_2}$$

Continued...

- By combining the above equation the instantaneous conversion may be written in terms of equilibrium conversion as follows:

$$\frac{dX_A}{dt} = \frac{k_1 (M + 1)}{M + X_{Ae}} (X_{Ae} - X_A)$$

- With conversions measured in terms of X_{Ae} , this may be looked on as a pseudo first-order irreversible reaction which on integration gives

$$-\ln \left(1 - \frac{X_A}{X_{Ae}} \right) = -\ln \frac{C_A - C_{Ae}}{C_{A0} - C_{Ae}} = \frac{M + 1}{M + X_{Ae}} k_1 t$$

- First- order irreversible reaction $-\ln (1 - X_A) = kt$

- NOTE: The similarity between equations for the first-order irreversible and reversible. The irreversible reaction is simply the special case of the reversible reaction in which $C_A = 0$, or $X_{Ae} = 1$, or $Kc = \infty$

Second-Order Reversible Reactions

- For the bimolecular-type second order reactions

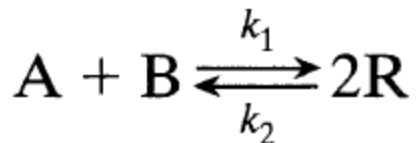
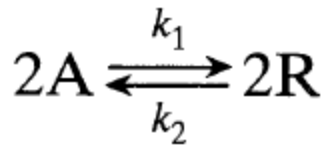
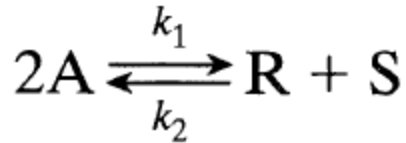
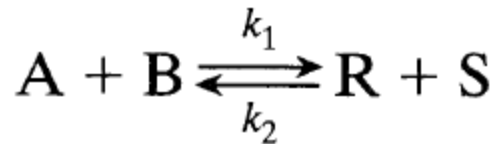

- with the restrictions that $C_{A0} = C_{B0}$, and $C_{R0} = C_{S0} = 0$, the integrated rate equations for A and B are all identical, as follows

$$\ln \frac{X_{Ae} - (2X_{Ae} - 1)X_A}{X_{Ae} - X_A} = 2k_1 \left(\frac{1}{X_{Ae}} - 1 \right) C_{A0}t$$

Reactions of Shifting Order

- In searching for a kinetic equation it may be found that the data are well fitted by one reaction order at high concentrations but by another order at low concentrations. Let us consider such a reaction as follows:

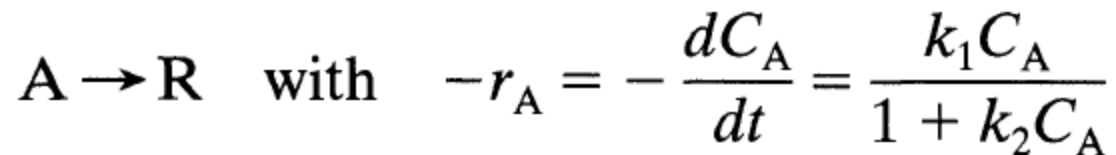

At high C_A —the reaction is of zero order with rate constant k_1/k_2
(or $k_2 C_A \gg 1$)

At low C_A —the reaction is of first order with rate constant k_1
(or $k_2 C_A \ll 1$)

- Now integrating the above equation we get

$$\ln \frac{C_{A0}}{C_A} + k_2 (C_{A0} - C_A) = k_1 t$$

- Or
$$\frac{C_{A0} - C_A}{\ln (C_{A0}/C_A)} = -\frac{1}{k_2} + \frac{k_1}{k_2} \left(\frac{t}{\ln (C_{A0}/C_A)} \right)$$

- hence
$$\frac{\ln (C_{A0}/C_A)}{C_{A0} - C_A} = -k_2 + \frac{k_1 t}{C_{A0} - C_A}$$

Continued...

- The rate form of shifting order reaction and some of its generalizations are used to represent a number of widely different kinds of reactions.
- For example, in homogeneous systems this form is used for enzyme-catalyzed reactions where it is suggested by mechanistic studies.
- It is also used to represent the kinetics of surface-catalyzed reactions.
- In mechanistic studies, this form of equation appears whenever the rate-controlling step of a reaction is viewed to involve the association of reactant with some quantity that is present in limited but fixed amounts; for example, the association of reactant with enzyme to form a complex, or the association of gaseous reactant with an active site on the catalyst surface.



Differential Method of Analysis of Data

- The differential method of analysis deals directly with the differential rate equation to be tested, evaluating all terms in the equation including the derivative dC_A/dt , and testing the goodness of fit of the equation with experiment. The procedure is as follows.
 1. Plot the C_A vs. t data, and then by eye carefully draw a smooth curve to represent the data. This curve most likely will not pass through all the experimental points.
 2. Determine the slope of this curve at suitably selected concentration values. These slopes $dC_A/dt = r_A$ are the rates of reaction at these compositions.
 3. Now search for a rate expression to represent this r_A vs. C_A data, either by (a) picking and testing a particular rate form, $-r_A = kf(C_A)$, (b) testing an nth-order form $-r_A = k(C_A)^n$: by taking logarithms of the rate equation

Continued...

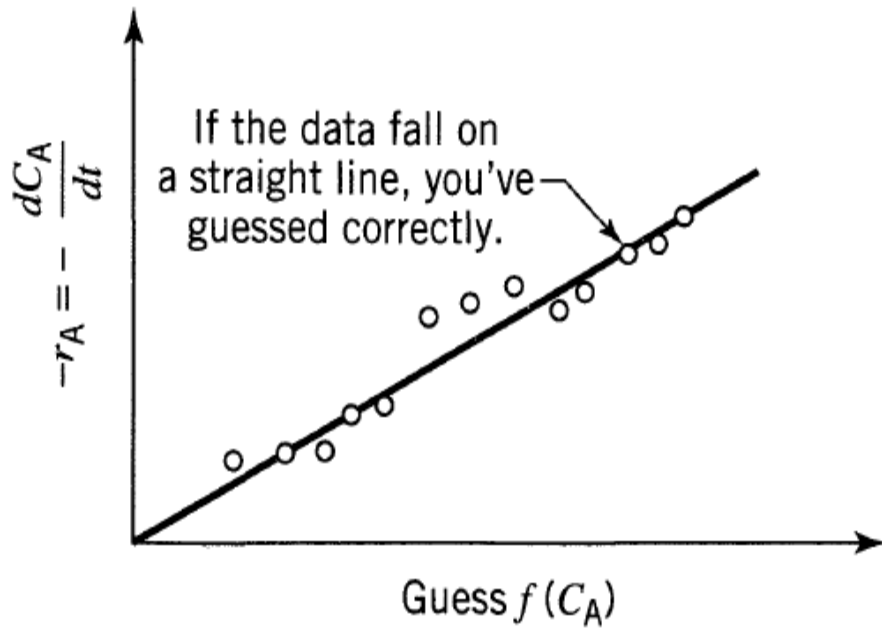

Fig: Test for the particular rate by the differential method

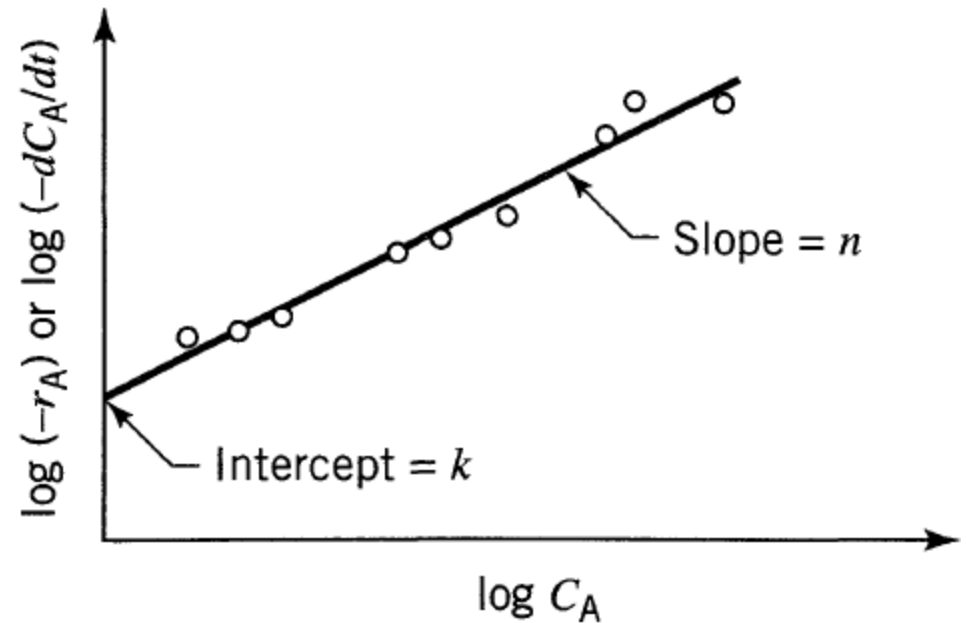
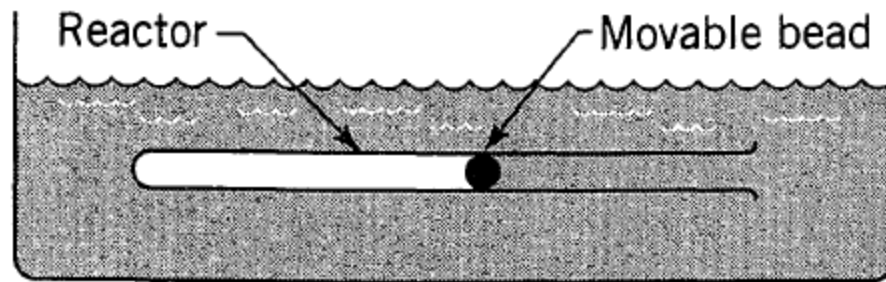

Fig: Test for the n -th order rate by the differential method

VARYING-VOLUME BATCH REACTOR

- These reactors are much more complex than the simple constant-volume batch reactor. Their main use would be in the micro-processing field where a capillary tube with a movable bead would represent the reactor (see Fig.). The progress of the reaction is followed by noting the movement of the bead with time, a much simpler procedure than trying to measure the composition of the mixture, especially for micro-reactors. Thus,



A varying-volume batch reactor

- V_0 = initial volume of the reactor
- V = the volume at time t .
- This kind of reactor can be used for isothermal constant pressure operations, of reactions having a single stoichiometry. For such systems the volume is linearly related to the conversion, or

$$V = V_0(1 + \varepsilon_A X_A) \quad \text{or} \quad X_A = \frac{V - V_0}{V_0 \varepsilon_A} \quad \text{hence} \quad dX_A = \frac{dV}{V_0 \varepsilon_A}$$

Continued...

- where ε_A is the fractional change in volume of the system between no conversion and complete conversion of reactant A. Thus

$$\varepsilon_A = \frac{V_{X_A=1} - V_{X_A=0}}{V_{X_A=0}}$$

- As an example of the use of ε_A , consider the isothermal gas-phase reaction

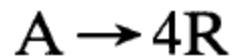

- By starting with pure reactant A,

$$\varepsilon_A = \frac{4 - 1}{1} = 3$$

- But with 50% inerts present at the start, two volumes of reactant mixture yield, on complete conversion, five volumes of product mixture. In this case

$$\varepsilon_A = \frac{5 - 2}{2} = 1.5$$

Continued...

- The ε_A accounts for both the reaction stoichiometry and the presence of inerts. Noting that

$$N_A = N_{A0}(1 - X_A)$$

- Therefore

$$C_A = \frac{N_A}{V} = \frac{N_{A0}(1 - X_A)}{V_0(1 + \varepsilon_A X_A)} = C_{A0} \frac{1 - X_A}{1 + \varepsilon_A X_A}$$

- Hence $\frac{C_A}{C_{A0}} = \frac{1 - X_A}{1 + \varepsilon_A X_A}$ and $X_A = \frac{1 - C_A/C_{A0}}{1 + \varepsilon_A C_A/C_{A0}}$

- **This is the relationship between conversion and concentration for isothermal varying-volume (or varying-density) systems satisfying the linearity assumption.**

References

1. H. Scott Fogler, **Elements of Chemical Reaction Engineering**, Prentice Hall, 4th edition, 2005.
2. Octave Levenspiel, **Chemical Reaction Engineering**, John Wiley & Sons, 3rd edition, 1999.
3. Mark E. Davis, Robert J. Davis, **Fundamental of Chemical Reaction Engineering**, McGraw Hill, 1st edition, 2003.
4. Schmidt. Lanny D. **The Engineering of Chemical Reactions** Oxford University Press, Inc., New York, NY (1998).

